

CODE NO. ITEM
 C12-1421-881 Canon AE-1 Program
 w/lens FD50mm f/1.8
 C12-1421-861 Canon AE-1 Program
 w/lens FD50mm f/1.4
 C12-1421-211 Canon AE-1 Program
 body only

Canon AE-1 PROGRAM

C12-1422-881 Canon AE-1 Program
 black w/lens FD50mm
 f/1.8
 C12-1422-861 Canon AE-1 Program
 black w/lens FD50mm
 f/1.4
 C12-1422-211 Canon AE-1 Program
 black body only

Programmed automation plus shutter-priority sophistication. System integration.



Specifications

Type: 35mm single-lens reflex AE (Automatic Exposure) camera with a focal-plane shutter.

Format: 24 x 36mm

Exposure Modes: Programmed AE, shutter-speed priority AE, AE flash photography with Canon dedicated Speedlites, and manual.

Usable Lenses: FD lenses: full aperture metering coupled with automatic diaphragm, and shutter-speed priority and programmed AE operations. FL lenses: stopped-down metering coupled with automatic diaphragm and shutter-speed priority AE operations.

Lens Mount: Canon Breech-lock mount.

Viewfinder: Fixed eye-level pentaprism.

Field-of-View: 94% vert. and 94% hor. of actual picture area; 0.83 magnification at infinity with standard 50mm lens.

Finder Information: Shutter button depressed slightly, exposure preview switch, or AE lock switch activates meter circuit and enables viewing of following information; to the right, outside finder field: aperture LED readout in full f/stops, flashing aperture readout indicates exposure limit; appearance of "P" when the camera is in the programmed AE mode, flashing "P" for slow-speed/camera shake warning in the programmed AE mode; appearance of "M" when the lens aperture ring is removed from its "A" automatic position; appearance of "blitz" \square mark to indicate completion of charge when dedicated Canon flash units are used, flashing \square as checklight to indicate proper flash auto exposure for the shot just taken with the 188A, flashing "32" as error mark to show wrong setting on the lens or the 188A; stopped-down metering index.

Mirror: Instant-return, with shock-absorber.

Focusing Screen: Supplied with new split-image rangefinder with microprism collar and laser matte screen. Seven other types of user-interchangeable screens available.

Dioptric Adjustment: Built-in eyepiece adjusted to standard -1.0 diopter. Interchangeable with ten other strengths.

Shutter: Cloth focal-plane shutter with speeds electronically controlled from 2 to 1/1000 sec., and B. X (flash) synchronization at 1/60.

Shutter Speed Selector Dial: Adjacent to film transport lever; B, 2, 1, 1/2 to 1/1000 sec. and PROGRAM. With safety guard to prevent unintentional dial movement.

Self-Timer: Electronically controlled for gaining 10 sec. delay. Electronic "beep-beep" sound to indicate operation; shorter "beep-beep" intervals two sec. before shutter release. Cancellation possible by pressing

battery check button or with main switch.

Meter Coupling Range: EV1 (1 sec. at f/1.4) to EV18 (1/1000 sec. at f/16) with ASA/ISO: 100/21° film and FD 50mm f/1.4 lens

Meter Sensitivity Pattern: Central emphasis average metering by SPC (Silicon Photo Cell).

Film Speed Range: ASA/ISO: 12/12° to 3200/36°.

Exposure Preview: LED readout can be activated by pressing the exposure preview switch.

Depth-of-Field Preview: Possible by pushing in the stop-down lever.

Battery Check: By means of "beep-beep" audible sound.

Power Source: One 6V alkaline-manganese (Eveready [UCAR] No. 537) or silver oxide (Eveready [UCAR] No. 544, JIS 4G13, Mallory PX28), or lithium (Mallory PX28L) battery. Battery lasts about one year under normal use.

Flash: Built-in flash hot shoe with direct contacts for dedicated Canon Speedlites, or for conventional electronic flash without cord attachments. Conventional PC socket at front of camera body for cord-type flash units.

Exclusive Flash Circuit: Automatically adjusts aperture opening and shutter speed (to 1/60 sec., regardless of the speed selected on shutter speed dial) with dedicated Canon Speedlites. Provision for M flashbulb sync at a 1/30-sec. or slower shutter speed.

Stop-Down Lever: For depth-of-field preview or metering (non-FD lens or non-fully-coupled accessories).

Winding Lever: Single or multiple strokes, 120° throw, 30° standoff.

Frame Counter: Additive type; automatically resets when back cover is opened, counts backwards sequentially as film is rewound.

Film Loading: Easy film loading with multi-slot take-up spool, emulsion side-out winding.

Coupler for Automatic Winding: Holes in the camera base plate for attaching motor drive and power winder. Possible to use camera/motor drive or power winder (A2) combination remotely for sequence shooting or single-shot.

Back Cover: Removable to accommodate the Data Back A.

Size: 141mm (W) x 47.5mm (D) x 88mm (H); 5-9/16" (W) x 1-7/8" (D) x 3-7/16" (H)

Weight: 575g (20-5/16 ozs.) body only; 745g (26-1/4 ozs.) with FD 50mm f/1.8 lens.

Subject to change without notice.

SELLING POINTS

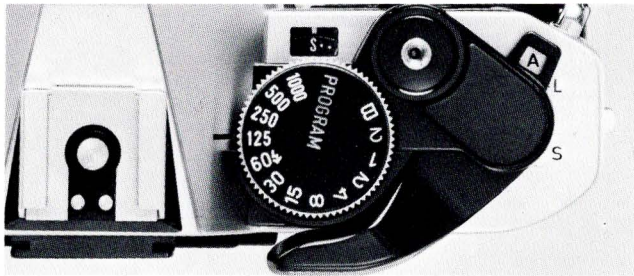
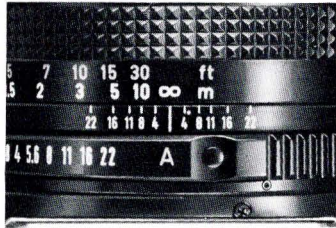
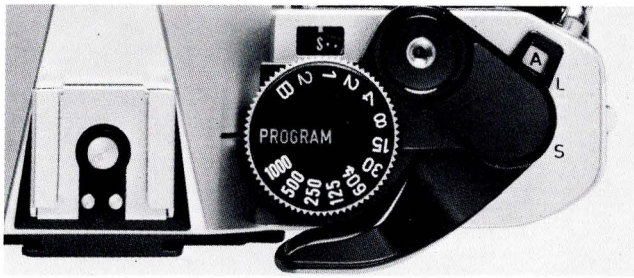

The Canon AE-1 PROGRAM is a superb example of contemporary camera design with the versatility of multi-mode operation. The AE-1 PROGRAM's three automatic exposure modes are programmed AE, shutter-speed priority AE, and fully automatic flash exposure.

Besides the choice between the programmed automation and shutter-speed priority mode, the camera offers a completely manual mode, i.e. manual setting of both shutter speed and aperture, with LED readout of recommended aperture for correct exposure.

Programmed AE

One particularly distinctive feature of the AE-1 PROGRAM even became part of the camera's name: the Programmed AE mode. This programmed AE mode makes even 35mm SLR photography "focus and shoot" easy by leaving both the shutter speed and aperture selections to the camera's computer brain.

Just set the shutter speed selector dial to "PROGRAM", make sure the lens aperture ring is set on "A", and then just focus and shoot! Even a person with no knowledge of photography can get perfect pictures from the very first roll.

In the programmed mode, depressing the shutter release button halfway illuminates a bright green  in the viewfinder, along with the aperture in use. As the light level varies, both speed and aperture change as illustrated in the programmed chart on page SG1-B13. The "P" will flash under low light conditions to warn that speeds below 1/30 sec. are being selected.

Shutter-Speed Priority AE

In the shutter-speed priority AE mode, you select a shutter speed and the camera will set the aperture. The appropriate f/stop is displayed in the viewfinder, providing a reference for the depth of field. The apertures automatically change as light levels increase or decrease. Should the lighting be outside the meter coupling range, the f/stop will blink, warning you to select a different speed. The beginner should find shutter-speed priority especially useful to prevent blur caused by camera shake and experienced photographer should find this mode useful to purposely cause blur for creative effect.

Manual

Even with a camera as fully automated as the AE-1 PROGRAM, both shutter speed and aperture can be at your command. It is possible to select any number of a variety of specific combinations of shutter speed and lens aperture to cope with special lighting situations and to add creativity to your work. The procedure is simple. You set shutter speed you want on the shutter speed selector dial and remove the lens aperture ring from the "A" automatic position. Upon partially depressing the shutter button, an "M" will show in the viewfinder, telling you the camera is on manual. The aperture in the viewfinder indicates correct exposure as a convenient reference but you can set any manual aperture you want.

Brighter Viewfinder and New Split Screen

Looking through the AE-1 PROGRAM's viewfinder, you will notice something different: you will see your subject brighter and clearer than ever. This is due to two factors: First, exposure information is not shown until you want it, when you depress the shutter release button partially.

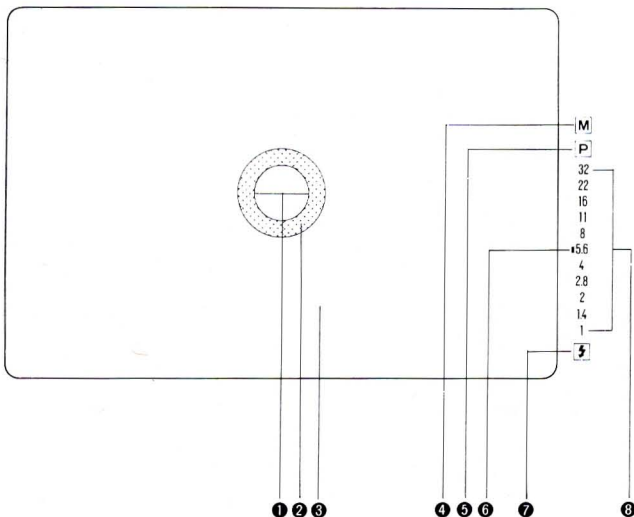

- ① New Split Rangefinder
- ② Microprism Collar
- ③ Laser-matte Screen
- ④ Manual Aperture Control LED
- ⑤ Programmed AE Control LED
- ⑥ Stopped-Down Metering Index Mark
- ⑦ Flash Charge-completion LED Display
(with Speedlite 188A: AE Flash Confirmation Signal as well)
- ⑧ Aperture Display

SELLING POINTS

Sturdy, Lightweight, Compact

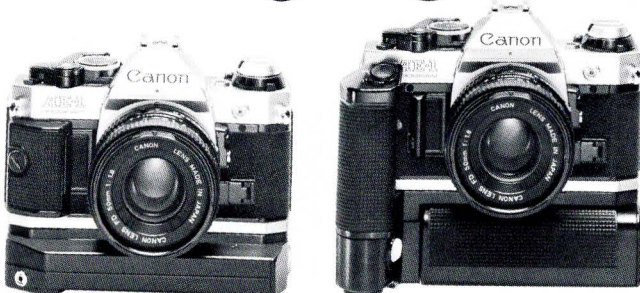



Until then you can totally concentrate on picture composition. Exposure information appears in clearly-viewed LEDs whose brightness varies according to the subject brightness so they are always easy to read. And as to the aperture, diode lights up only for the aperture selected by the camera's metering system.

Equally important is the AE-1 PROGRAM's New Split rangefinder and laser-matte screen. A world's first, the New Split is composed of crossed prisms with two angles forming a grating. With the single-angled conventional split-image, the central rangefinder did not always work too well with lenses having a maximum speed of f/5.6. One or the other rangefinder semi-circles darkened and you were compelled to use the outer focusing areas.

But with the New Split focusing screen, the image remains bright even at the small opening of f/5.6. All focusing screens for the AE-1 PROGRAM have laser matte and the new surface eliminates problems of moiré too. For all general photographic purpose, the standard screen with New Split rangefinder, microprism collar and full focusing screen should be sufficient. Seven other types of focusing screen are available for the AE-1 PROGRAM and all focusing screens are interchangeable by the user.

Automatic Speedlites

Designed with the AE-1 PROGRAM is another addition to the Canon Speedlite series: the Speedlite 188A for flash automation similar to the arrangement for the Canon AE-1 in that a special flash unit, when fitted to the hot shoe of the AE-1 PROGRAM, will set the proper shutter speed (1/60 sec.) on the camera and one of the auto-flash apertures on the lens for automatic flash exposure (while the lens aperture ring is kept at the "A" automatic position). The arrangement is identical only this far. To indicate completion of charge, a green "blitz" mark  appears in the viewfinder. And to indicate that there was sufficient illumination for the shooting distance, the green  flashes on and off for two seconds (again right in the viewfinder) after firing. The latter feature of auto flash checklight (confidence light) right in the viewfinder is exclusive to the 188A/AE-1 PROGRAM combination.

Automatic Winders

To keep you shooting paced with the action, the AE-1 PROGRAM offers a choice of three motorized film advance systems: the new Power Winder A2, the Motor Drive MA with the choice of two power packs, and the Power Winder A (not shown). Lightweight and compact, each quickly attaches to the camera's body to form a well-balanced, versatile combination.

The Motor Drive MA has three speed settings, including single frame, and can shoot at 4 frames per second. The Battery Pack MA and the rechargeable Ni-Cd Pack MA are the two power packs for the Motor Drive MA, motor unit. The Power Winders A and A2 shoot at approximately 2 fps. The Power Winder A's single frame and continuous shooting modes are both controlled with the camera's shutter release, while the A2 has a handy switch for selecting either continuous or single frame shooting.

For the AE-1 PROGRAM/motor drive or power winder (A2) combination, remote shooting is possible using Remote Switch accessories with connecting cords or wireless shooting without cords using the Wireless Controller LC-1.

NOMENCLATURE

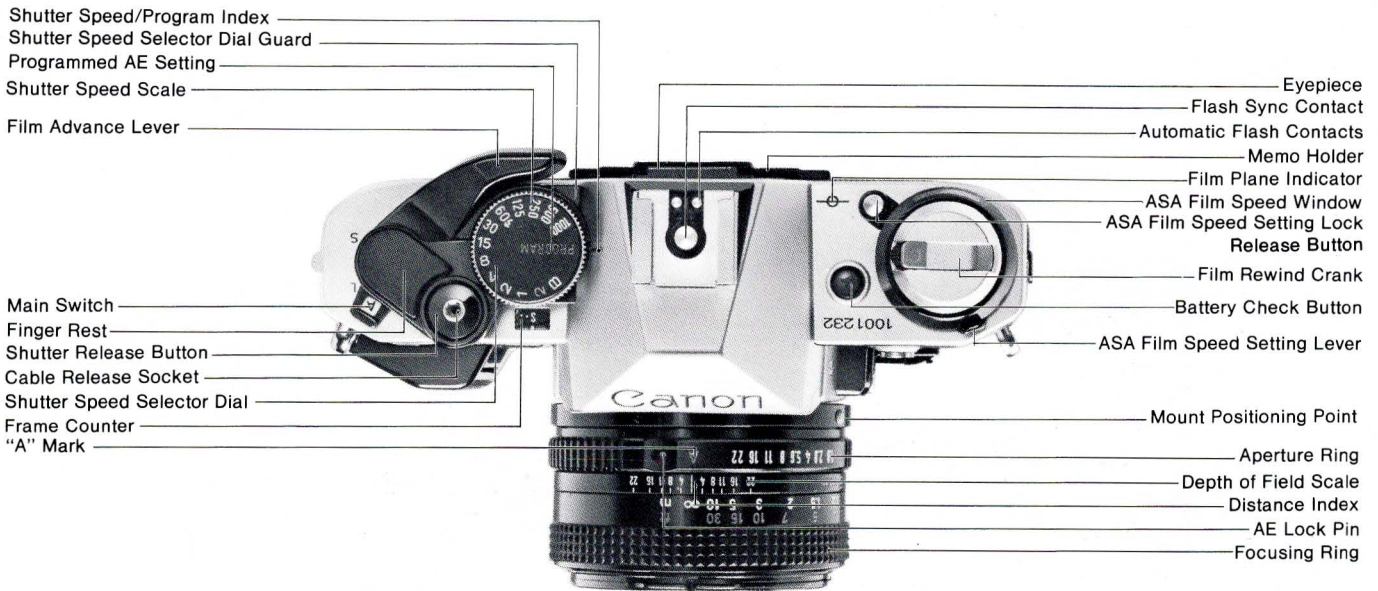

SELLING POINTS

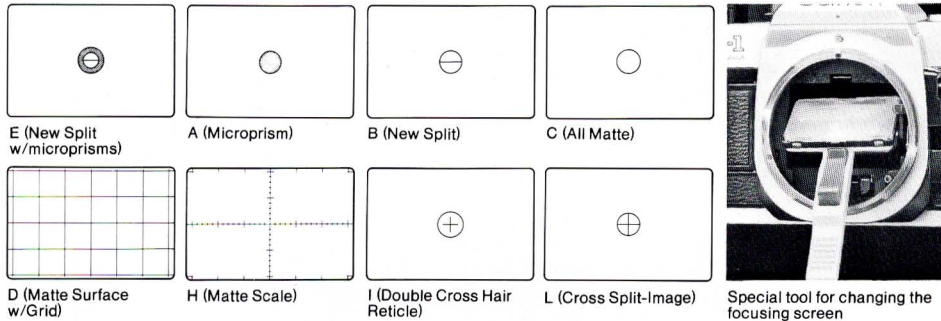
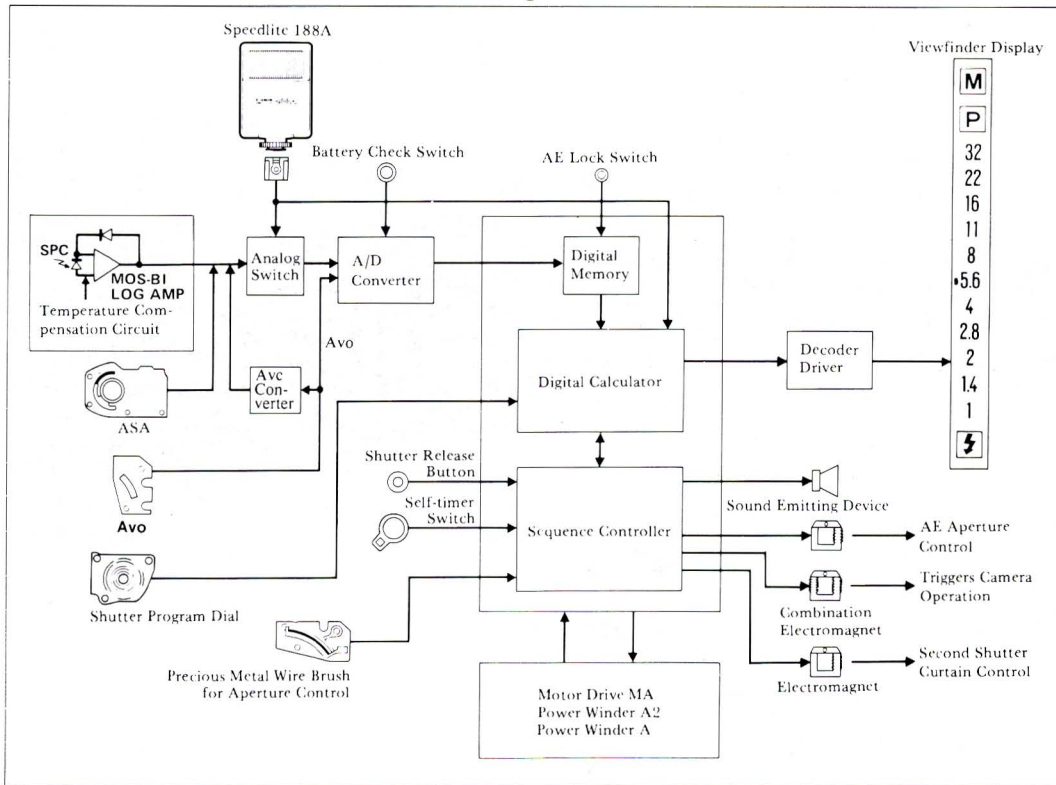

Focusing Screens

As a result of using laser-matte screen for all focusing screens, the AE-1 PROGRAM's viewfinder is 1.5 times brighter than its predecessors. Light rays hitting the surface are less diffused, so less light is lost. And focusing is made considerably easier on the AE-1 PROGRAM standard screen E (New Split w/microprisms) and B type (w/out the microprism collar), with modification in the centrally-placed split-image.

A world's first, the New Split uses multiple prisms (like an echelette grating) with degrees of slope angle, one steep and one gentle. There is no longer a darkening of one or other half of the split field at aperture of about f/5.6 or less. The L type screen also has special innovation. Displacement of the central area of the screen into four sections gives a positive indication in attaining exact focus. All focusing screens for the AE-1 PROGRAM shown above are interchangeable by the user.

Programmed Combinations of Shutter Speed and Aperture in Programmed AE (with FD 50mm f/1.4 Lens)

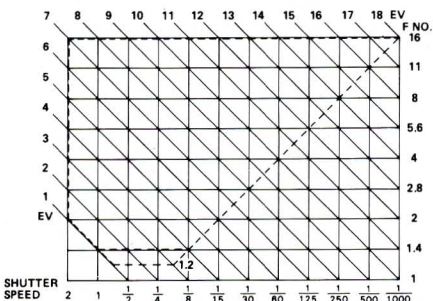

Canon AE-1 PROGRAM reacts to changes in light level by varying both shutter speed and lens aperture in the programmed mode. This chart shows typical programmed response with f/1.4 lens and ASA 100 film.

Meter Sensitivity Pattern

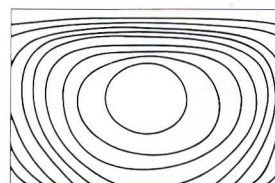

Optical Path of the Viewfinder

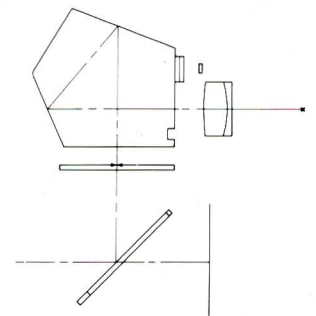

MAIN ACCESSORIES



Canon FD Lenses

- World-renowned for sharp pictures with high resolution
- Faithful color rendition with multi-layer coating
- Uniform color rendition from all lenses
- Canon Breech-lock mount with a locking system for quick lens changes
- Compact, lightweight design
- Extended focal length range
- Wide choice of lenses within the same focal length
- Wide choice of short and long zooms

Motor Drive MA

- Couples to the base of AE-1 PROGRAM camera with simple and positive operation
- Shutter release button on the Motor Drive MA for operating the camera horizontally

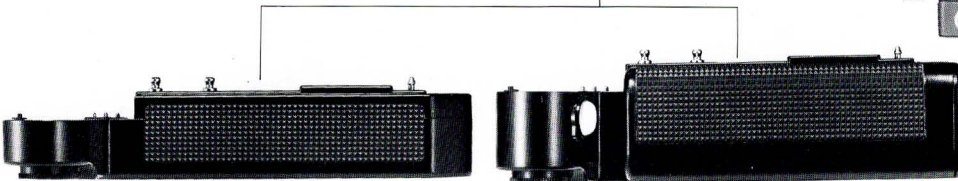

Ni-Cd Pack MA

- Couples to the base of Motor Drive MA with simple and sure operation
- Lightweight compact design with neat lines
- Three shooting modes of high speed (4 frames per sec.), low (3 fps) speed and single-frame
- Auxiliary motor drive release on the Ni-Cd Pack MA to make vertical shots easier
- Shooting capacity of more than 60 rolls in normal temperature and more than fifteen rolls in cold temperature for 36-exposure films per charge
- Remote shooting from a distance possible

Battery Pack MA

- Couples to the base of Motor Drive MA with simple and sure operation
- Three shooting modes of high speed (4 frames per sec.), low (3.5 fps) speed and single-frames
- Regular-use auxiliary motor drive release on the Battery Pack MA to make vertical shots easier
- Special-use auxiliary motor drive release on the Battery Pack MA, a high-speed override, to throw the motor drive into high-speed sequence run instantly from low speed or single-frame settings
- Shooting capacity of more than 60 rolls in normal temperature and more than five rolls in cold temperature for 36-exposure films
- Remote shooting from a distance possible

Data Back A

- Simultaneous recording of data with each exposure
- Provision for manual imprinting of data
- Maximum data capacity of 6 digits and use of some letters in the alphabet in combination
- Selection switch to assure clear impression of data for different film-types



Speedlite 188A

- Guide number of 82 for ASA/ISO:100/21°, in feet
- Displays necessary exposure data in the camera's viewfinder (feature exclusive to the AE-1 PROGRAM)
- Checklight (or confidence light) right in the viewfinder (feature exclusive to the AE-1 PROGRAM) to indicate proper autoflash exposure
- Two-f-stop selection
- Energy-saving circuitry
- Automatic setting of proper shutter speed (1/60 sec.) on the camera and one of two apertures on the lens for autoflash exposure
- Coverage of 28mm lens with the Wide Adapter 188A and 35mm lens without adapter
- Minimum and maximum automatic working distances shown right on the back of the flash unit

Note: Other dedicated Canon Speedlites 577G, 533G, 199A, 177A, 155A, and 133A can also be used with the AE-1 PROGRAM.



Power Winder A

- Two frames per second shooting
- Sequence or frame to frame shooting control by simple to-and-fro pressure on the camera's shutter release button
- Motor drive section and power source-in-one compact unit
- LED indicates end of film or insufficient supply of battery power

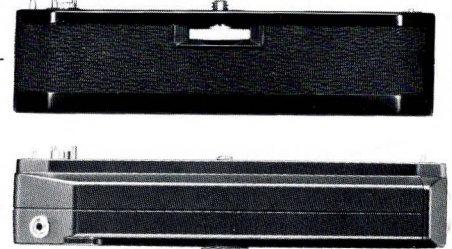

Power Winder A2

- Convenient two-position switch for sequence mode of two frames per second or single-frames (frame to frame) shooting
- Motor drive section and power source-in-one compact unit
- Remote shooting from a distance possible
- LED indicates end of film or insufficient supply of battery power
- Choice of alkaline-manganese, carbon zincs, or Ni-Cd batteries as power source



Wireless Controller LC-1

- Enables using camera/motor drive or camera/winder combination remotely for the owner of the AE-1 PROGRAM
- Three-channel transmitter and receiver
- Matching channels enables simultaneous operation of a number of cameras in the same field

SPECIFICATIONS

Motor Drive MA Unit Specifications

Motor Drive MA

Structure: Consists of a motor for film winding, an electromagnetic clutch, a set of gears, and a release button for connection to the camera base.

Operation: Activated by the shutter release button on the camera or on motor drive for horizontal position shots when the Ni-Cd Pack MA or Battery Pack MA is connected.

Size: 151mm (W) × 67mm (D) × 80mm (H)

Weight: 200g

Ni-Cd Pack MA

Structure: Consists of a motor control circuit and built-in Ni-Cd battery.

Winding speed: Three changeable modes of H (4 frames/sec.), L (3 frames/sec.) and S (single frame).

Operation: Activated by the auxiliary motor drive release on Ni-Cd Pack MA (vertical shot), shutter release button on camera (horizontal shot), Remote Switch 3 or 60 using connecting cords, or with the transmitter of Wireless Controller LC-1.

Shutter speed coupling range: All speeds, in both shutter-speed priority and programmed modes.

Frame counting: Frame counter of the camera shows the number of frames exposed.

Safety circuit: When the film is completely wound or when the battery power fails, film winding automatically stops and the LED on Ni-Cd Pack MA flashes.

Conveyable number of film rolls: In normal temperature about 60 rolls of 36-exposure film using H mode.

Power source: Built-in Ni-Cd battery, 14.4V.

Size: 151mm (W) × 61mm (D) × 29mm (H)

Weight: 205g (including the battery)

Battery Pack MA

Structure: Consists of a motor control circuit and a chamber for loading twelve AA size batteries with a battery magazine.

Winding speed: Three changeable modes of H (4 frames/sec.), L (3.5 frames/sec.) and S (single frame).

Operation: Activated by the auxiliary motor drive release on Battery Pack MA (vertical shot) or camera (horizontal shot) or instant high speed button on the Battery Pack MA for switching instantly to high speed mode (4 frames/sec.) from low speed or single-frame modes.

Shutter speed coupling range: All speeds, in both shutter-speed priority and programmed modes.

Frame counting: Frame counter of the camera shows the number of frames run.

Safety circuit: When the film is completely wound or when the battery fails, film winding automatically stops and the LED on Battery Pack MA flashes.

Conveyable number of film rolls: In normal temperature about 60 rolls of 36-exposure film using H mode.

Power source: Twelve AA size batteries, alkaline manganese or carbon zincs.

Size: 151mm (W) × 67mm (D) × 40mm (H)

Weight: 395g (including batteries)

Canon Power Winder A2 Specifications

Winding speed: Up to two frames per second for sequence shooting. Single-frame winding for intermittent shooting possible.

Operation: Activated by the camera's shutter release button, Remote Switch 3 or 60 using connecting cords, or with the transmitter of Wireless Controller LC-1.

Shutter speed coupling range: 1/60 to 1/1000 sec. for AE sequence shooting. "B" or 2 to 1/1000 for single-frames. No AE photography at "B". (In the programmed mode, the appearance of f/4 or smaller apertures in the finder, i.e. f/5.6, f/8, etc. indicates shutter speed in use is 1/60 or faster).

Frame counting: Frame counter of the camera shows the number of frames exposed.

Safety circuit: When the film is completely wound or when the battery power fails, the Power Winder A2 automatically stops and its LED flashes.

Conveyable number of film rolls: In normal temperature about 40 rolls using alkaline-manganese batteries, about 20 rolls using carbon zincs, about 60–80 rolls using Ni-Cd batteries, of 36-exposure film.

Power source: Four AA size batteries, alkaline-manganese, carbon zincs, or Ni-Cd.

Size: 140.8mm (W) × 27.5mm (H) × 53.4mm (D)

Weight: 275g (including batteries)

Accessories: Case

Canon Data Back A Specifications

Attachment: To camera's back cover after removal of the back cover.

Data setting: Done by three rotating dials.

Right dial: 32 figures and blank (0 to 31 and □).

Center dial: 39 figures and blank (0 to 31, A to G and □).

Left dial: 39 figures and blank (0 to 9, 81 to 92, Roman numerals I to X, a to g, and □).

Data imprinting: By special synchronization cord and built-in lamp. Manual imprinting of the data with the manual imprint button.

Exposure adjustment: Three different positions. Black and white and 2 color positions. Color 1: ASA/ISO:64/19° to 160/23° color films.

Color 2: ASA/ISO:25/15° to 10/11° color films.

Indicator lamp: LED lamp indicates data imprinting.

Power source: One 6V silver oxide battery (Eveready or UCAR) #544; good for 5,000 flashes or one year use.

Size: 145mm (W) × 33mm (D) × 54mm (H)

Weight: 160g (including battery)

Accessories: Special synchronization cord and case.

Canon Speedlite 188A Specifications

Type: Electronic computer flash unit with a series control system.

Attachment: Clip-on type with a directly coupled contact. Tightened by lock nut.

Guide numbers: 82 (ASA/ISO:100/21°) in feet without any adapter. 41 (ASA/ISO:25/15°) in feet without any adapter. 52

(ASA/ISO:100/21°) in feet with Wide Adapter. 26 (ASA/ISO:25/15°) in feet with Wide Adapter.

Flash coverage: For 35mm format, covers angle of view of a 35mm lens without any adapter. Covers angle of a 28mm lens with Wide Adapter.

Recycling time (on automatic): Approximately 8 seconds using alkaline-manganese batteries. Approximately 6 seconds using Ni-Cd batteries.

Number of flashes (on automatic): Approximately 200 using alkaline-manganese batteries. Approximately 70 using Ni-Cd batteries.

Color temperature: Same as that of daylight.

Flash duration: 1/700–1/50,000 sec.

Auto flash system: Selection of two color-coded positions (red, green) with corresponding auto apertures and auto working distance ranges. MANU (manual) position provided on the same switch. Auto coupling ranges: Red mark: 1–9m (3–30ft); 1–5.6m (3–18ft) when using Wide Adapter. Green mark: 0.5–4.5m (1.5–15ft); 0.5–2.8m (1.5–9ft) when using Wide Adapter.

Auto apertures at ASA/ISO:100/21°: Red-f/2.8, Green-f/5.6.

Film speed range: ASA/ISO: 25/15° – 800/30°.

Aperture range: f/1.4–f/16

Pilot lamp: Glows to indicate the flash has enough charge to fire a flash.

Test firing: By pressing the pilot lamp after it glows.

Auto check: By checklight  in the view finder which will glow after actual firing.

Power source: Four AA size alkaline-manganese (AM3, LR6) or Ni-Cd batteries.

Size: 68mm (W) × 103mm (H) × 52mm (D)

Weight: 290g (including batteries)

Accessories: Case, Wide Adapter

Canon Wireless Controller LC-1 Specifications

Operation range: About 60m in a straight-line course with no obstacles in the path. If the angle between the receiver and transmitter is 20°, about 35m; if 45°, about 15m.

Operation mode: C (continuous) for sequence shooting, S (single) for single-frame shooting.

Number of channels: Three

Attachment to the camera: Receiver mounts into camera's accessory shoe. Synchro cord plugs into the remote control jack on the power winder or motor drive device.

Battery life: More than 500 times with a new battery provided a minimum interval of less than 0.5 sec. is used between each operation.

Battery check: Operation confirmation lamp doubles as battery checklight.

Operation confirmation lamp: Provided on the receiver. Prior to shooting, operation confirmation lamp can be used to check if the distance between the transmitter and the receiver is close enough.

Power source: For the receiver, DC 9V transistor battery, Eveready 216, Mallory M1604 or the equivalent. For the transmitter, two AA size alkaline-manganese batteries.

Size: Receiver, 35 × 62 × 84.5mm; transmitter, 49 × 120 × 37mm.

Weight: Receiver, 153g (including the battery); transmitter, 172g (including batteries).

ACCESSORIES

VIEWFINDER ACCESSORIES

CODE NO.	DESCRIPTION
5-40701-00	Magnifier S
5-41041-00	Magnifier Adaptor S
5-40712-00	Angle Finder A-2
5-40711-00	Angle Finder B
5-59212-00	Eye Cup 4S

DIOPTRIC ADJUSTMENT LENSES

CODE NO.	DESCRIPTION
5-05072-00	Dioptric Adjustment Lens S (+3)
5-05073-00	Dioptric Adjustment Lens S (+2)
5-05051-00	Dioptric Adjustment Lens S (+1.5)
5-05075-00	Dioptric Adjustment Lens S (+1)
5-05076-00	Dioptric Adjustment Lens S (+0.5)
5-05041-00	Dioptric Adjustment Lens S (0)
5-05078-00	Dioptric Adjustment Lens S (-0.5)
5-05079-00	Dioptric Adjustment Lens S (-2)
5-05081-00	Dioptric Adjustment Lens S (-3)
5-05082-00	Dioptric Adjustment Lens S (-4)

FOCUSING SCREENS

CODE NO.	DESCRIPTION
C51-9521	Focusing Screen A (Microprism)
C51-9527	Focusing Screen B (New Split)
C51-9522	Focusing Screen C (All Matte)
C51-9523	Focusing Screen D (Matte Surface with Grid)
C51-9524	Focusing Screen E (New Split/Microprism)
C51-9525	Focusing Screen H (Matte Scale)
C51-9526	Focusing Screen I (Double Cross Hair Reticle)
C51-9528	Focusing Screen L (Cross Split Image)

EQUIPMENT FOR MOTORIZED PHOTOGRAPHY

CODE NO.	DESCRIPTION
C51-9371-211	Motor Drive MA Set (consists of Motor Drive MA and Battery Pack MA)
C51-9371-201	Motor Drive MA
C58-5441-011	Battery Pack MA
C58-5461	Battery Magazine MA
C58-5451-311	Ni-Cd Pack MA Set (consists of Ni-Cd Pack MA and Charger MA)
C58-5451-001	Ni-Cd Pack MA
C56-2097	Ni-Cd Charger MA
C51-9331-001	Power Winder A set (w/Battery Pack, Soft Case)
C58-5411-011	Battery Pack A for Power Winder A
C51-9501	Power Winder A2
5-81071-00	Extension Cord E1000
5-22051-00	Remote Switch 60
5-22041-01	Remote Switch 3
C58-5351-211	Wireless Controller LC-1 Set (consists of Receiver and Transmitter)
C58-5351-001	LC-1 Transmitter
C58-5352	LC-1 Receiver

FLASH ACCESSORIES

CODE NO.	DESCRIPTION
C50-0371-201	Speedlite 133A Set in Case
C50-0311-201	Speedlite 155A Set in Case
C50-0361-211	Speedlite 177A Set in Case w/Wide Adapter
C50-0411-211	Speedlite 188A Set in Case w/Wide Adapter
CA4-2332	Wide Adapter for 188A and 177A
C50-0321-211	Speedlite 199A Set in Case w/Wide Adapter
C50-1481	Wide Adapter for 199A
C50-1431-001	Battery Magazine D
C50-1441-001	Synchro Cord A
C50-0301-221	Macrolite ML-1 Set
Y12-6725	Wide Adapter ML-1
Y19-0165	Macrolite Adapter 55
Y19-0166	Macrolite Adapter 52
Y12-6756	Tightening Ring 55
Y12-6758	Tightening Ring 52
C50-0381-221	Speedlite 533G Set
C50-0391-211	Speedlite 577G Set
C50-1561	Battery Magazine 533G
C50-1501	One-Touch Bracket G
C50-1491	Sensor Unit G20

CODE NO.	DESCRIPTION
C50-1492	Sensor Unit G100
C50-1541	Wide Adapter 533G-24
C50-1543	Wide Adapter 577G-24
C50-1542	Wide Adapter 533G-20
C50-1544	Wide Adapter 577G-20
C50-1545	Tele Adapter 533G
C50-1546	Tele Adapter 577G
C50-1547	Adapter G for Motor Drive MF
C50-1571	Battery Magazine TP
C50-1581	Ni-Cd Pack TP
C50-1557	Ni-Cd Charger TP
C50-1521-221	Transistor Pack G Set (consists of Ni-Cd Pack TP, Ni-Cd Charger TP and Power Cord)
C50-1521-311	Transistor Pack G Set (consists of Battery Magazine TP and Power Cord)

DATA BACK ACCESSORIES

CODE NO.	DESCRIPTION
C51-9351-011	Data Back A

EQUIPMENT FOR UNDERWATER PHOTOGRAPHY

CODE NO.	DESCRIPTION
C56-7051-221	Canon Marine Capsule A set (including Marine Capsule A Body, O Ring and Grease, Front Housing MCA S, 52mm Close-up lens 240, Focus Adaptor MCA No. 6, Aperture Ring Adaptor MCA Type A and Carrying Case for Marine Capsule A.)
C56-7051	Canon Marine Capsule A Body (including O Ring and Grease)
CS1-0312	Focus Adaptor MCA No. 6
CS1-0304	Aperture Ring Adaptor MCA Type A
C48-6311	Carrying Case for Marine Capsule A Set
C56-7062	Front Housing MCA Type S
C56-7061	Front Housing MCA Type FE
C56-7063	Front Housing MCA Type T
XG9-0075	O Ring and Grease
CS1-0035	Aperture Ring Adaptor MCA Type B
CS1-0315	Aperture Ring Adaptor MCA Type C
C54-3751	72mm Close-Up 240
CS1-0307	Focus Adaptor MCA No.1
CS1-0308	Focus Adaptor MCA No.2
CS1-0309	Focus Adaptor MCA No.3
CS1-0310	Focus Adaptor MCA No.4
CS1-0311	Focus Adaptor MCA No.5
CS1-0313	Focus Adaptor MCA No.7
CS1-0314	Focus Adaptor MCA No.8

MISCELLANEOUS ACCESSORIES

CODE NO.	DESCRIPTION
5-03111-00	Camera Holder F
5-63061-00	Release 30
5-63062-00	Release 50
C58-5471-011	Canon External Battery Pack A Set
C58-5471-001	Canon External Battery Pack A
CG4-0014-001	Battery Cord C-A
CG4-0015-001	Battery Cord PW
9-00700	The ABC's of Picture-Taking Ease

CASES

CODE NO.	DESCRIPTION
C46-1111	Case S for AE-1 Program (FD 50mm f/1.8 and FD 50mm f/1.4)
C46-1112	Case L for AE-1 Program (FD 50mm f/1.2, FD 50mm 1.2L)
4-10000-S1	Compartment Case A
4-10000-S3	Compartment Case DL
C46-1101	Case HA-2 for AE-1 Program (for FD 35-70mm f/4)

MACROPHOTO & CLOSE-UP ACCESSORIES

CODE NO.	DESCRIPTION
4-20601-20	Copy Stand 4
4-25901-03	Handy Stand F52 Set
4-46201-20	Photo Micro Unit F
4-25117-00	Macro Hood
4-25301-00	Extension Tube A
4-25302-00	Extension Tube B
4-25303-00	Extension Tube C
4-25323-01	Extension Tube FD 50 Universal in Case

CODE NO.	DESCRIPTION
4-25324-01	Extension Tube FD 25 Universal in Case
4-25325-01	Extension Tube FD 15 Universal in Case
4-25315-00	Extension Tube FL 15
4-25321-00	Extension Tube FL 25
4-25316-01	Extension Tube M Set
4-25316-00	Extension Tube M5
4-25317-00	Extension Tube M10
4-25322-00	Extension Tube M20
4-25711-00	FL58 Macrophoto Coupler
4-25721-00	FL55 Macrophoto Coupler
C42-5731	FL52 Macrophoto Coupler
5-42011-00	Lens Mount Converter A
5-42021-00	Lens Mount Converter B
5-42031-00	Lens Mount Converter E
5-42071-00	Lens Mount Converter P
0-00000-33	Lens Mount Converter N
5-43231-01	58 Close-Up 450
5-43241-01	58 Close-Up 240
5-43251-01	48 Close-Up 450
5-43331-01	48 Close-Up 240
5-43571-00	55 Close-Up 450
5-43561-00	55 Close-Up 240
C54-3741	52 Close-Up 450
C54-3731	52 Close-Up 240
5-59042-20	Bellows FL
5-59181-02	Slide Duplicator 52
5-59181-01	Slide Duplicator 55
43-6370	Attachment Ring 48 for Slide Duplicator
CA4-2418	Attachment Ring 52 for Slide Duplicator
43-6371	Attachment Ring 55 for Slide Duplicator
43-6372	Attachment Ring 58 for Slide Duplicator
C26-1151-211	Macrophoto Lens 20mm f/3.5 in Case
C26-1161-211	Macrophoto Lens 35mm f/2.8 in Case
C55-9044-211	Auto Bellows
C42-6501	Macro Auto Ring
C42-6511	Double Cable Release
C42-6521	Focusing Rail
C42-6541	Macro Stage
C55-9182-011	Duplicator 35-55R
C55-9182-012	Duplicator 35-52R
C42-6571	Roll Film Stage
C42-6581	Duplicator 8
C42-6591	Duplicator 16
C42-6693	Macrophoto Adapter MA-58
C42-6692	Macrophoto Adapter MA-55
C42-6691	Macrophoto Adapter MA-52
C42-6681	Duplicator G
C42-6612	Vari-Extension Tube M30-55
C42-6611	Vari-Extension Tube M15-25

BODY COVER

CODE NO.	DESCRIPTION
4-52021-00	Camera Cover R-F

STRAP

CODE NO.	DESCRIPTION
5-61141-00	Neck Strap 7 with Pad

PLEASE NOTE: For further information on accessories please see the sections as follows:

Sect. 2:	Canon Interchangeable Lenses
Sect. 3:	Canon F-1 System and SLR Accessories
Sect. 6:	Miscellaneous Accessories Cross-Referenced (including Canon Filters, Cases, etc.)