

**DEFINITIVE GUIDE TO CARTRIDGE AND SHOTSHELL RELOADING**

# **THE ABC'S OF** 7<sup>th</sup> Edition **RELOADING**



**Edited by  
Bill Chevalier**

**LEE**  
LEE PRECISION, INC.

- **The Basics for Novices**
- **Advanced Procedures for Seasoned Handloaders**
- **The Latest in Tools, Techniques & Components**

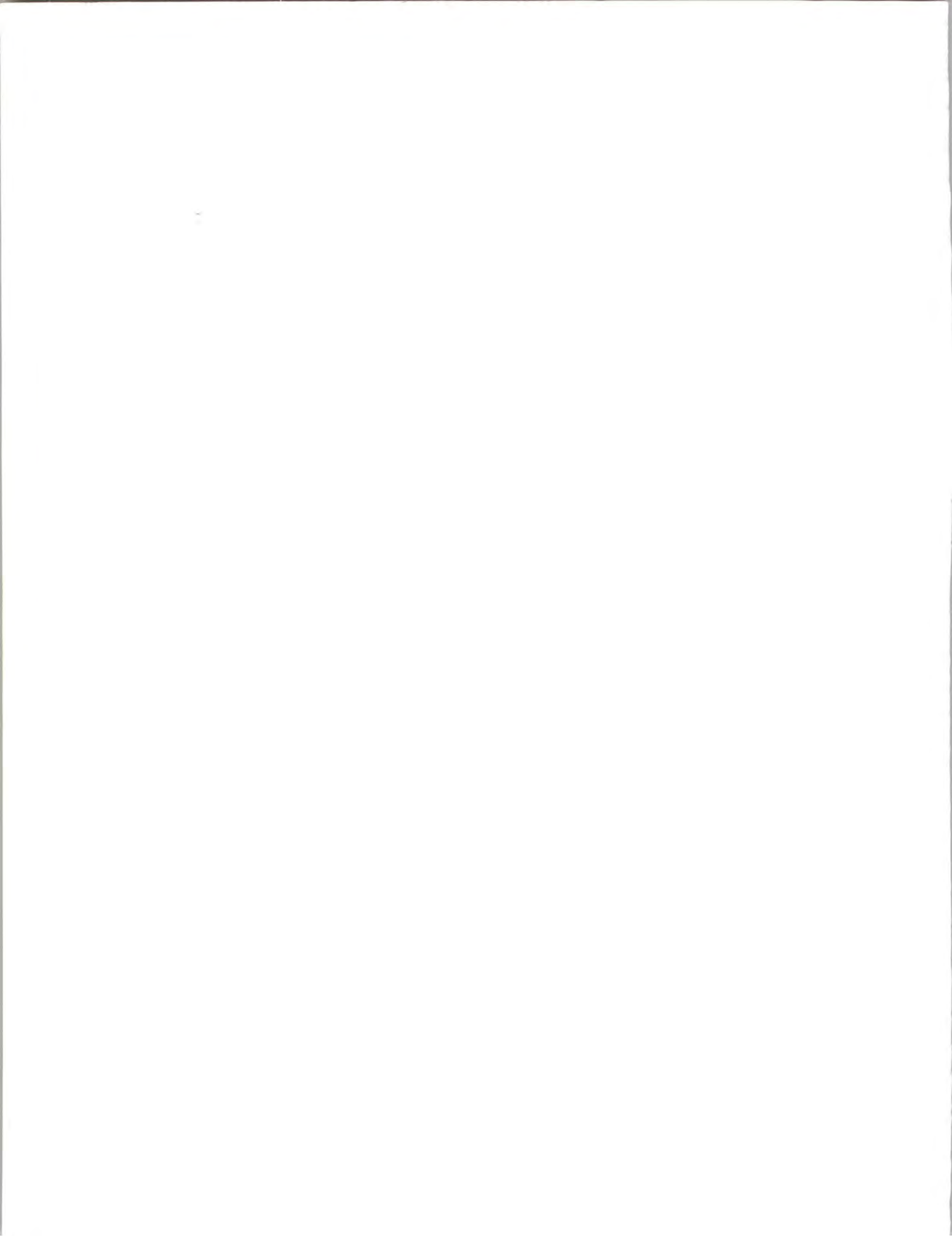

**THE ABC'S OF** **7th EDITION**  
**RELOADING**

**Edited by Bill Chevalier**

©2004 KP Books



**700 East State Street • Iola, WI 54990-0001**  
**715-445-2214 • 888-457-2873**

Our toll-free number to place an order or obtain  
a free catalog is (800) 258-0929.

All rights reserved. No portion of this publication may be reproduced or transmitted in any form or by any means, electronic or mechanical, including photocopy, recording, or any information storage and retrieval system, without permission in writing from the publisher, except by a reviewer who may quote brief passages in a critical article or review to be printed in a magazine or newspaper, or electronically transmitted on radio, television, or the Internet.

Library of Congress Catalog Number: 2004093856

ISBN: 0-87349-851-8

Designed by Kara Grundman  
Edited by Ken Ramage

Printed in the United States of America

## About the Editor

**BILL CHEVALIER, EDITOR OF THE ABC'S OF RELOADING, 7<sup>TH</sup> EDITION**, has been involved in the reloading industry for more than 30 years. His advertising agency, Chevalier Advertising and Public Relations, Lake Oswego, OR, has handled the National Reloading Manufacturers Association since 1973 when he was first appointed Executive Secretary for that group. He retired in 2003.

Working closely with the National Rifle Association, Bill helped develop the NRA's Certified Course in Reloading, and wrote the first draft of the textbook for the course. More than 1000 NRA instructors are now certified to teach reloading. Their names and phone numbers are listed on the NRMA's website, [www.reload-nrma.com](http://www.reload-nrma.com)

## About the Cover

Lee Precision, known for years for well-designed, low-cost reloading tools and accessories, has introduced their first cast iron reloading press, the single-stage **Classic Cast Press**. The new press was developed from scratch, and incorporates features important to the handloader.

For example, the press had to have as much—or more—stroke travel as any other compound-linkage press in order to full-length size the largest magnum case with ease. Accordingly, it had to be made of cast iron as no other material has the heft or rigidity that cast iron offers.

Other desirable characteristics: The operating lever must be convertible to right- or left-hand operation, and balanced. Spent primer disposal must be positive, and priming needs to be done at the bottom of the stroke for best feel and convenience. Finally, the fit, finish and quality had to be tops.

The cast frame is a classic O-design with a five-inch opening. The base sits flat on any bench and three mounting holes are arranged for secure mounting.

The red baked finish is so tough it is actually applied before machining. Then the frame is machined in a turning center by rotating the painted casting in a balanced fixture to deliver as perfect alignment between the ram and die as is possible. A removable bushing accepts all standard 7/8-14 dies.

The ram is threaded to accept a shell holder adapter, which holds the automatic primer arm. Large and small primer arms are included, by the way. The tubular ram allows primers to pass through to an included clear PVC tube with cap. Remove the cap and route the tube to your trashcan. This press catches every primer, without fail.

The shellholder insert mounts to the end of the ram, accepts standard shellholders and holds an automatic primer arm. The backside of the insert is drilled and tapped for the Lee automatic bullet feeder. The shellholder insert is removable and can be replaced with a shellholder for the 50 BMG case.

The linkage is solid steel, plated with a corrosion-resistant yellow dichromate, and attaches to the base with hardened steel pins that feature an oil hole for easy lubrication of the upper pivot points. The operating lever is adjustable for both angle and length, and topped with a wood ball grip. Left-handed? The operating lever, primer arm and shell holder are completely reversible.

Price of the new **Classic Cast** press? Under \$100.

**Other Lee reloading tools and accessories on the covers:**

**Lee's Auto-Prime** is said to be the fastest, most accurate priming tool made. You never touch the primers — empty the box of primers onto the

tray, shake gently and the primer-flipper surface turns the primers right-side-up for loading. Includes trays for large and small primers. The **Lee Auto-Prime II** (*not shown*) attaches to your reloading press and primes on the ram upstroke; fits any brand press with a vertical ram.

Bill helped design the NRMA's well-known reloading bench plans, which thousands of shooters have used to build these sturdy benches, and has the original bench in his Portland, Oregon home, where he loads shot-shell and metallic ammo.

Handloaders need safe, properly tested loading data, and that is found in Lee's **Modern Reloading, Second Edition**, by Richard Lee. This new edition contains over 26,000 loads, including hundreds for cast bullets. New and interesting information makes this an important handloading reference.

The **Lee Safety Scale** is simple yet highly accurate, and very sensitive. It's magnetically damped and has an approach to weight lifter enclosed in the heavy base. The scale's phenolic beam is tough but, like glass, it can't be bent, which means it can never get out of adjustment as long as it's not physically broken. This powder scale is said to be the easiest to use, most accurate and sensitive model made. Use the handy **Lee Powder Funnel** to transfer the measured charge from the scale pan (*or powder dipper*) to the primed cartridge case.

**Lee Reloading Dies** come in various sets and models. Shown is the Lee 2-Die Rifle Set for the 30-06 Springfield cartridge.

**Lee's Perfect Powder Measure** is said to be almost as good as a scale because it's so accurate. Through excellent design and by using the right nylon material, the measure eliminates cut powder and jerky action of the lever, plus there's no drum binding or powder bridging, and the micrometer adjustment positively locks. Unlike other measures, the adjuster reads directly in cubic centimeters. Just multiply the charge in grains by the cc for one grain and you have the setting. By the way, the steel powder measure stand and drop tube are included. A useful accessory is Lee's **Universal Charging Die** (*os/s*) that, when attached to the **Perfect Powder Measure** and fitted to a reloading press, automatically charges most cartridge cases.

**Lee Shellholder Sets** fit both the Auto Prime and all brands of reloading presses. Each set includes eleven of the most popular sizes to accommodate over 115 different cartridges.

The back cover shows another view of the **Classic Cast Press**, the **Deluxe Pistol Die Set**, and the **Universal 3 Jaw Chuck** that attaches to the **Zip Trim** (*not shown*) and holds any case from the 25 ACP to the 460 Weatherby.

**For more information, contact:**

Lee Precision, Inc.  
4275 Highway U  
Hartford WI 53027  
262-673-3075  
[www.leeprecision.com](http://www.leeprecision.com)

# Introduction

**THIS 7<sup>TH</sup> EDITION OF THE ABCS OF RELOADING** is unique, not because I edited the manuscripts or even have the background and experience to flood the reader with reams of advice on reloading. If I have brought anything to its success, it is an effort to show many more sides to reloading than just another how-to book on rolling your own. During my tenure serving many advertising and public relations clients, I have known many of the finest hunting and shooting writers in this land. As you first peruse the book, you'll see many familiar names of authors whose work shows up regularly in publications serving the interests of those folks deeply involved in all aspects of the sport.

I have had the privilege of previewing their works that are in the pages of this edition. The scope of their knowledge and extent of their experience in many fields of the shooting sports are nothing short of amazing. The range of their experimentation to produce loads for their particular fields of endeavor shows true dedication. And their ability to put it all down so it makes sense makes the job of editing their work easy, and at the same time humbling.

So whether you're a beginner, a long-time reloader or an expert in a facet of this field, there's a lot here for you.

When we are endeavoring to get more shooters involved in reloading, we preach about the traditional benefits to reloading your own ammo. First, you'll save money. Next, you'll be a better shooter when you understand what goes into making (or remaking) a cartridge. Then, you'll be able to formulate your own load to do precisely what you want for your own (not somebody else's) kind of shooting. And reloading makes a good hobby, it's a family enterprise and it's fun. All these reasons are valid, but there is more to the story. Much more.

To be sure, we have not neglected the basics about the tools and components you'll need to get into this game, and how to do it safely. There is solid instruction on how

the various steps are performed, plus the hows and whys of doing them correctly. If you plan to become a serious and proficient reloader, you need to absorb and understand this information thoroughly. And you should read our discussion of interior, exterior and terminal ballistics to further deepen your understanding of our sport.

To really appreciate the original works of our authors, you had better understand the basics, because you won't find much step-by-step stuff in a truly exciting story about reloading for dangerous game. Many of these stories read like adventures, because the guys who wrote them have been there and done that. Maybe cowboy action shooting has piqued your interest, but how much have you read about reloading ammo for both smokeless powder guns and for blackpowder cartridges used in this growing sport? This book doesn't get into muzzleloading, but blackpowder cartridge guns are regaining popularity for competition and for hunting.

You'll find brain-teasing stories about accuracy for accuracy's sake, a discussion about when to reload versus just buying ammo and how to let your computer help you turn into a better reloader. You'll become intimately acquainted with chronographs, loading slugs for various shotguns, and perhaps the best treatise ever on reloading steel shot.

How about rifle loads for turkeys, handgun loads for big game, what kind of bullets to use for big game and how to fashion handgun cartridges that will knock over a steel pig at 100 meters? There's lots of information about shotshells, how to reload for effective patterns and make your shots count in trap, skeet and sporting clays. Varmints meet their Waterloo if you reload correctly for them, and you can learn how the real handgun experts reload for the fastest shooting contests around. And just wait till you read about the lengths benchresters go to fashion ammo that will consistently group far smaller than a quarter-inch.

*Enjoy!*

*Bill Chevalier*

# Contents

<b>Introduction</b> .....	4
<b>Chapter 1: Start with Safety Lead Hazards in the Shooting Sports</b> by Robert D. Williams, Ph.D.....	6
<b>Chapter 2: The Cartridge Case</b> .....	17
<b>Chapter 3: Understanding Pressure and Headspace</b> .....	30
<b>Chapter 4: Primers</b> .....	41
<b>Chapter 5: Powders</b> .....	49
<b>Chapter 6: Bullets</b> .....	60
<b>Chapter 7: Casting Bullets</b> .....	70
<b>Chapter 8: Bullet Sizing and Lubricating</b> .....	80
<b>Chapter 9: Tooling Up for Reloading</b> .....	89
<b>Chapter 10: Rifle Cartridge Reloading</b> .....	102
<b>Chapter 11: Handgun Cartridge Reloading</b> .....	116
<b>Chapter 12: Shotgun Ammunition Reloading</b> .....	129
<b>Chapter 13: Ballistics</b> .....	140
<b>Chapter 14: Sources and Resources</b> .....	144
<b>Chapter 15: Quest for Accuracy by Dave Workman</b> .....	148
<b>Chapter 16: The Chronograph by Mike Thomas</b> .....	155
<b>Chapter 17: Reloading Vs. Cheap Ammo by Charles E. Petty</b> .....	161
<b>Chapter 18: Big Game Bullets by Chub Eastman</b> .....	167
<b>Chapter 19: Loading for Varmint Fun by Mike Thomas</b> .....	173
<b>Chapter 20: Heavy Hitters by Dave Fackler</b> .....	179
<b>Chapter 21: Loads for Dangerous Game by Chub Eastman</b> .....	184
<b>Chapter 22: Reloading for Slamming Steel by Todd Spotti</b> .....	189
<b>Chapter 23: Reloading for Handgun Competition by Steve Gash</b> .....	197
<b>Chapter 24: Handloading for Hunting Handguns by Dave Workman</b> .....	206
<b>Chapter 25: Computers Can Help the Reloader by Bob Krawczyk</b> .....	214
<b>Chapter 26: Modern Reloading, Old Fashioned Sport by John Taffin</b> .....	220
<b>Chapter 27: Old Time Cowboy Action by John Taffin</b> .....	228
<b>Chapter 28: Reloading for the Clay Sports by Bob Krawczyk</b> .....	237
<b>Chapter 29: Buy 'em or Stuff 'em by John Haviland</b> .....	244
<b>Chapter 30: Fast Track Reloading by John Haviland</b> .....	251
<b>Chapter 31: New Era for Traditional Hunting by Kenny Durham</b> .....	258
<b>Chapter 32: Rifle Loads for Turkeys by Steve Gash</b> .....	267
<b>Chapter 33: Really Fussy Reloading by Jacob Gottfredson</b> .....	274
<b>Chapter 34: Reloading Steel Shot by Tom Roster</b> .....	281
<b>Handloaders' Library</b> .....	288

Before beginning any activity, a solid foundation is needed to build upon, and reloading is no different.

# Start with Safety

**EVERY BOX OF** cartridges, every loading manual, advises that these loadings are for “modern arms in good condition.” What is a modern gun? Like any other arbitrary definition, it has fuzzy edges. Modern gun designs (such as modern-looking double-action revolvers) were developed in the late 1880s. Modern semi-automatic pistols were on the market by 1900. Bolt-action, 30-caliber rifles intended for high-pressure (40,000 to 60,000 psi) smokeless powder ammunition were in general military use by 1895. Roughly speaking, the era of modern gunmaking begins around 1886-1900.

The real issue is whether the gun for which you wish to reload can take the pressures of modern ammunition. For instance, a tightly locking Winchester Low Wall single shot or Stevens target rifle from the late 19th century can be safely used with modern, high-velocity 22 Long Rifle ammunition. To use such ammunition in a light revolver or pistol from the same era will destroy it. Even guns made as recently as the 1920s may not be safe with the high pressures generated by the high-velocity loadings. The 22 Long Rifle Reising automatic pistol of that period had a very thin breechblock, which





This reproduction 1874 Sharps rifle (*bottom*) is made of modern steel (4140 for the receiver and 1195 for the barrel). It is capable of handling modern high-pressure 45-70 loadings to 28,000 psi. The Allin "trapdoor" 45-70 Springfield (*top*) was made in 1888. The receiver is mild steel, casehardened. The barrel is mild "decarbonized" steel. Its maximum pressure rating, at the time of manufacture, was 25,000 psi. It is not a modern gun and must be loaded accordingly.



A 94-year-old 32 ACP Colt Model 1903 pocket pistol (*bottom*) and a Cold-War-era 9mm Makarov—both qualify as "modern guns."

regularly splits on the first firing of a high-speed round, so it is to be used with standard velocity ammunition only.

While a modern-looking revolver such as the Model 1889 Colt Navy double action looks very like the 38 Special police models that have been in use for over 60 years, it was made for the 38 Long Colt blackpowder cartridge. Some of these early guns will chamber a contemporary smokeless-powder 38 Special cartridge. However, to fire such a loading in one of these old Colts is to court disaster.

Some early smokeless-powder guns were by no means as strong as later models chambered for the same cartridge. The soft steel on U.S. Krag rifles—Models 1892/1896—was not up to the pressure of some heavy smokeless-powder loadings, and those guns began to develop cracks around the bolt locking lug after prolonged use. Krag and early 1903 Springfield rifles were inspected "by eye," the proper color indicating proper heat treatment of barrel and receiver steel. When Springfield receivers started failing with higher-pressure loadings, the heat treatment process was improved. This occurred at serial number 800,000.

The Colt Single Action Army revolver (Model 1873) is still

being made. The original was a blackpowder gun. The steel was later improved and some internal redesigning was done, making it safe for smokeless loadings. Colt has advised that guns with serial numbers below 160,000 are for blackpowder only! Except for serial numbers and a few minor details neither the '03 Springfield nor the Colt SAA has changed in external appearance since their introduction.

Early 38 Colt semi-automatic pistols (Models 1900, 1902, 1903) are chambered for the 38 Colt Automatic cartridge, no longer manufactured. The same cartridge, in terms of dimensions, is still on the market as the 38 Super Auto. This is the old 38 Auto with a much heavier charge of powder. It is poison for the older guns.

The original Model 1895 Winchester lever-action rifle was chambered for the 1903 Springfield's 30-06 cartridge. For some reason this rifle got a reputation as having an action that was stronger than the Springfield when, in fact, it was weaker.

Older guns can be fired quite safely if you are aware of their limitations and don't try for "improved" performance. Determining what is and is not a "modern" gun in terms of



The U.S. standard 30-06 Springfield cartridge (left) and Russian 7.62x54mm Mosin rifle cartridge are not compatible. Some Russian rifles have had chambers recut to take the '06. The smaller-diameter 30-06 has plenty of room to swell and burst in the oversize Russian chamber.



The 30-06 Springfield (left) and 8mm Mauser rounds are close enough in size the Mauser can be fired in a 30-06 chamber. This will happen ONCE! The gun will be wrecked, along with the shooter's face, by the tremendous pressures generated by an oversize bullet.

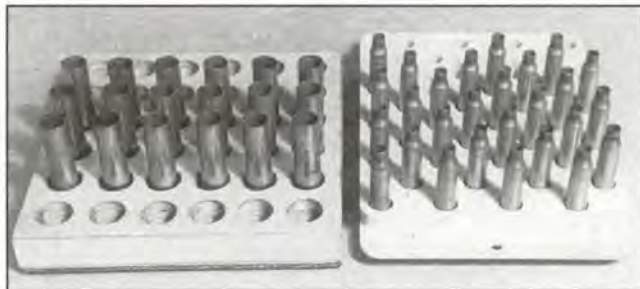

Loading blocks can be homemade from wood (left) or of moulded plastic (right). Loading blocks are not merely a convenience; they are a necessity to keep you from double-charging a cartridge case.

its strength falls under the COIK limitation. COIK stands for **C**lear **O**nly **I**f **K**nown. Therefore, defining what is a safe "modern" gun at times requires some knowledge beyond the appearance and the date it was introduced. Thus if the gun you are planning on reloading for is questionable in any way regarding the caliber, its age and/or mechanical condition, have it checked by a competent gunsmith—and if you don't like the first answer, a second opinion won't hurt.

Occasionally what might be termed "nightmare guns" turn up on the used market. These are standard rifles, often surplus military guns, which some amateur gunsmith has attempted to rework into a caliber different from the one it was originally intended to fire. The 6.5mm and 7.7mm

Japanese Arisaka and the 7.62mm Russian Mosin-Nagant rifles have been found converted to take the 30-06 Springfield cartridge.

Some were only half-converted: the chamber recut, but the barrel left untouched. In the case of the 6.5 rifle, 30-caliber bullets were squeezed down to 25-caliber in the barrel, creating tremendous pressures. Some of these rifles, amazingly, held together for a while. The Russian rifle was never intended to take the pressures of the 30-06, and no recutting of the chamber can replace metal at the rear of the chamber, which is considerably oversize for the 30-06 cartridge. Case swelling and eventual ruptures are a matter of time. There is no way such a butchered rifle can be made right short of rebarreling. Even then the new caliber should be one that will not give pressures greater than that of the original cartridge. If you plan to shoot and reload for a centerfire rifle, know what you have—don't guess! If, on firing some commercial ammunition, there is any sign of trouble, stop right there. What is a trouble sign? The best quick and easy means is to look at the fired cartridge case. If it looks significantly different from an unfired one, is now swollen or misshapen with a flattened or pierced primer, take the rifle and case to a good gunsmith for an analysis.

### The Loading Process

The loading process is not terribly complicated, though it does involve a number of steps. Each step is there for a reason. It may not be apparent to the beginner, at the outset, why those steps are there. This often seems to be a good excuse to take a shortcut and eliminate a particular step. Here is a scenario in which the beginning reloader can find himself: You start reloading cases in what you think is a very safe manner. Each cartridge case is sized and decapped, just as this book tells you to do. Then you insert a new primer, also according to the manual. You carefully weigh the powder charge on a good scale and even weigh the bullets to make sure there's no more than 1/2-grain difference in weight. After weighing the powder charge to an accuracy level of less than 1/10-grain, you put it directly in the case and immediately seat the bullet.

Everything works fine with this system until the day you're in the process of loading and someone comes to the door. You leave a cartridge case sitting on the loading bench, charged with a small charge of fast-burning powder that has disappeared in the dark bottom of the cartridge case. After dealing with the visitor, you return to the bench to continue loading, picking up where you think you left off. You carefully measure out a charge of powder and funnel it into the case. Since you're wary of accidentally getting two charges in one case, you immediately seat a bullet and add the finished cartridge to the box you had been filling.

A double charge is exactly what resulted.

Every instruction manual will warn you not to do this. Use a loading block, a small plastic or wood tray that holds cartridge cases heads down. They cost a couple of bucks, or you can make your own by boring the proper-sized holes



Straight from the chamber of horrors. Before your loading bench looks like this, it's time to clean up and get organized. With such a mess, it's easy to mistake and/or waste a lot of time puzzling over what's really in those various bins and boxes.



The 223 (left) has a shorter neck than the 222 Magnum.



All are ready to shoot, except the one in the middle is a 222 Magnum and the rest are 223. If you plan to load similar calibers, extra caution is needed to keep the cases, loaded ammunition and, in some instances, bullets separate.

through a piece of plank and gluing a flat bottom on it. A loading block is a safety device allowing the reloader a second chance to inspect charged cartridges before seating a bullet, because there might be the slight possibility that one of those cartridges got too much powder.

One new reloader recalled this exact error, much to his chagrin:

"I discovered my error while target shooting at a friend's farm. The double-charged case wrecked a nice old Springfield, the purchase price of which would have bought an amazing number of loading blocks. I was very lucky, because the people who had designed and built that Springfield had built-in some good safety features. These saved my eyesight."

Many reloaders owe a lot to those folks who designed and built their guns—people who were smarter than they are. Everybody who loads will throw double charges. The careful ones won't do it very often and they'll catch their mistakes before they are fired. Once is all it takes to ruin a gun. Once is all it takes to ruin your face, eyesight, hearing, and if you are really unlucky, kill you.

Follow the steps listed in the reloading manuals, all of

them in the proper order. They are there for a good reason.

Many reloading accidents stem from simple carelessness, like avoiding steps, taking shortcuts, and not paying attention to your work. Reloading is a solitary activity. Don't try to watch television or chat with friends while you reload. Reloading is a simple task requiring concentration and paying attention to details. Close the door to the room where you reload to keep others out, especially children. If there's an interruption, stop at the completion of an operation and then deal with whatever it is. If this isn't possible, back up one step and do it over. Because it is repetitive, reloading can become routine and tedious. When it becomes boring is the time to take a break. Never reload when you are tired or ill, because this dulls your concentration.

### Handling Materials Safely

Teachers constantly remind us that neatness counts. In reloading it will be your gun that will tell you, not your teacher. A cluttered, messy reloading area leads to more mistakes. Primers not put away get mixed with the next batch that may be different. Cartridge cases that are similar can be mixed and the wrong one can wind up in the loading

press, jamming it, or worse—dropped in a box of loaded ammunition of a different caliber. Mismatched ammunition can wreck guns and shooters.

Primers are perhaps the most potentially dangerous component of the reloading hobby. They come packaged in little packets of 100, separated in rows or in individual pockets in a plastic holder. There is a very good reason for this. While modern primers are well sealed there is always the possibility that minute amounts of priming compound can coat an exposed surface of a primer and flake off as dust. If primers are dumped into a can or bottle this dust can accumulate and be detonated, followed by all the primers in that can or bottle, in something approaching 25/1000-second. That's faster than most people can let go of a can or bottle. Primers should never be dumped more than 100 at a time and this should be done only in a plastic primer tray. Shaking a can or bottle of primers is really tempting fate. Primer trays should be wiped clean if there is any evidence of residue on them.

The more advanced loading tools are often equipped with automatic primer-feeding devices that will occasionally jam. Dealing with such a jam is a delicate process. All primers that can be removed should be taken out before attempting to clear a jam. Problems with feeders are best dealt with via a call or e-mail to the manufacturer of the loading equipment.

Safety glasses are a must whenever you reload. When loading using an automatic primer feeder, safety glasses are absolutely vital because primers can explode. Aeronautical engineer Edward Murphy came up with a very good set of rules known as "Murphy's Laws" regarding how and why things fail, concluding that they fail at the worst possible time—airplanes when they are flying, guns when they are being fired, primer feeders when they are packed full of primers.

Modern smokeless powder is far safer to handle than gasoline or other flammable solvents, acids or caustic substances such as lye-based drain cleaners. Powder can, however, be mishandled and this leads to trouble. Powder left in a measure or unmarked container can lead to guessing about what it is, and a wrong guess can be disastrous. Powder should always be kept in the original container. Never use an old powder can or bottle because it is too easy to contaminate your powder, or mistake which label is right. Powders should never be mixed. This can happen if some is left in a measure and a different powder is poured on top. Such contaminated powder is worthless and should be discarded. Likewise, powders that are in unlabeled containers, from unknown sources, are not worth keeping. Even though they might look like another, you can't really be sure so they should be considered as "unknown" and discarded. It's not worth risking your gun—let alone your eyesight, hearing and,

**The right and wrong way to store primers. Dropping or shaking the bottle could cause the primers inside to detonate with enough violence to remove a good part of your hand. The box is specially designed to keep the primers apart. It is made of soft plastic and paper. If you are careless and leave it open, dropping it will cause no problems beyond a spill.**



**Plastic primer trays or "flippers" are handy to keep primers on the bench and turn them the right way up for seating. They should be kept clean of any residue.**





The tall thin tube in the center rear of this progressive reloading press is filled with a stack of primers. If the feeding mechanism jams, the stack can explode if you do not clear it properly. If a jam occurs, read the manual, and if in doubt, call the manufacturer for assistance.

(Below) Never store powder in an old powder can that contained a different powder, as this photo shows. Too much chance for a mistake in the future. Powder should ALWAYS be stored in the original container.



yes, your life to experiment for the sake of saving a few dollars of material.

Disposing of such powder is easy, but should be done sensibly. It can be burned outside, on open ground, in small amounts of no more than a couple of tablespoons at a time. Far easier is to scatter it on your lawn or flowerbed because it adds nitrogen. It will break down in the weather rather quickly. Unexploded primers that have been damaged are best buried after soaking in a lye solution.

Failure to recognize what sort of powder you are dealing with can have disastrous consequences. Recently, a would-be blackpowder shooter bought a new-made blackpowder revolver. The dealer at the gun show didn't have any blackpowder for sale, advising the buyer to come by his shop the following week where he had plenty. The buyer really wanted to try out his new gun that weekend. A helpful neighbor allowed as how he had some old blackpowder shotgun shells. These could be broken down, he figured, the powder extracted and used.

They did that. There was powder in the shells, and it was black in color. Two heads may be better than one, so long as the cooperative effort is not simply a pooling of ignorance. When the gun fired the charge blew off the top strap, blew out the chamber being fired and the chambers on either side. Fortunately no one was seriously injured. A basic ignorance was the fault. With very few exceptions all gunpowder is colored black by a graphite coating, including the fast-burning smokeless shotgun powder that was contained in the neighbor's shells. Never guess about powder.



Smokeless powder is far safer to store or handle than many common household products. It is highly flammable, but less so than gasoline, petroleum-based cleaning fluids and similar household items.

Related accidents have been caused by reloaders loading bullets into blank cartridges. Blanks are loaded with a very fast-burning type of powder that will produce a loud report. If a bullet is loaded on top of such powder, rather than being accelerated down the barrel, the powder burn is so rapid that the bullet has no more than begun to move before the pressure has jumped to a catastrophically high level and the bullet acts like a plug. In essence, this is a bomb.

Recognizing powder, obviously, is easiest when it is in clearly marked containers. There is, however, an additional point to be made here. Powders are identified by manufacturer, trade name and often numbers. There are powders on the market that are very similar, but not the same, which can be confused if the reloader does not have a clear understanding of what he is dealing with. The IMR Powder Co. makes a powder called IMR 4831 (formerly made by DuPont). The Hodgdon Powder Co. produces a similar powder called 4831 and is labeled H4831. The IMR powder is much faster burning than Hodgdon's and loading data for H4831 would be very dangerous to use with the IMR propellant. To confuse things a little more, both companies market a powder with the designation 4895, IMR 4895 and H4895 respectively. These are very similar in terms of their burning characteristics and are virtually interchangeable. The recent acquisition of IMR reloading powders by Hodgdon hopefully will sort out this situation.

### Loading Data and Loading Manuals

The typical loading manual provides loading data for individual cartridges using a variety of powders and bullets that have been tested and found to be suitable for that particular cartridge. The powder types and charges listed for each cartridge are given as "starting loads" and "maximum loads." Often there will be an "accuracy load" listed that performed particularly well in the firearm used for the tests. This data is the result of rigorous testing over long periods of time. It involves the efforts of a number of engineers and technicians using the latest and most sophisticated test equipment available. This loading data brackets the lowest safe pressure and velocity loads up to the highest. Working



**These are not the same powders, although the number is identical. Read the powder reference section for further information and never guess about the burning characteristics of a powder.**

within this range, the reloader can work up a loading that performs best in his gun.

The semi-experienced reloader is occasionally tempted to go beyond the bounds of whatever loading guide he is using and try something else. This is fine if the “something else” is to avail himself of more loading books containing tried and proven data, and not simply guessing on the basis of, “What if I tried 52 grains of \_\_\_\_\_?” The dangers of exceeding the upper limits of various loadings should, by now, be clear to the reader. There is, though, an apparent danger from going in the opposite direction. A certain amount of press has been given to a phenomenon known as detonation. This involves excessively high pressures generated by reduced loads of slow-burning powders—charges below those recommended by the reloading manuals. Never guess at the burning characteristics of a powder, or exceed the recommended charges on either end of the loadings recommended in the manuals.

The weight, composition and fit of the bullet in the barrel are factors in the pressure equation. Heavier bullets boost pressures, as do those made of harder material. The size of the bullet also plays a role. The tighter the fit of the bullet in the barrel, the greater the force needed to drive it through.

When using modern components, loading problems are usually simple and straightforward, if the reloader keeps in mind that the changing of any component can affect pressure. These include the type of case (military vs. commercial), the type of primer (pistol vs. rifle vs. the magnum version of either), the make of primer or case, and the lengthening and thickening of the case mouth in bottlenecked cartridges after repeated reloadings. A final consideration is the capacity of the case. The larger it is the lower the pressure, all other things being equal.

All these factors must be carefully weighed in the loading game, particularly when working toward maximum pressure/velocity loadings. At this point, particularly with guns

of less than the best design and strongest materials, the gap between a safe maximum loading and a destroyed gun can be very close, and a slight variation in one of the above mentioned pressure factors can lead to a case rupture and disaster. The danger is greatest in what might best be termed the area of “advanced reloading.” This takes in the obsolete, the foreign and the wildcat or experimental cartridge. In loading these cartridges, the reloader often finds himself on *terra incognita*, faced with guns whose internal dimensions may vary considerably from book descriptions, and with cartridges that are old or of otherwise doubtful quality. Often a gun may not be clearly marked as to the exact caliber. Rifles chambered for the German 8.15x46R cartridge were a popular “bring-back” following WWII. This cartridge came in many case shapes, and the rifles had bore diameters ranging from .313- to .326-inch, with .318 and .323 being the most common. Guns do turn up that have been rechambered for some cartridge other than the one listed in the books or on the barrel. When in doubt, make a chamber cast. The most common problem is that there is often little or no data on loading these cartridges. In such instances even the experienced expert must proceed with extreme caution.

On the subject of published loading data there are a couple of final caveats. Old manuals dating from the early 1950s or before were developed without the benefits of today’s modern test equipment. Often the weaknesses of particular guns were not known at the time or if they were, those guns were not being used to an extent great enough to justify their inclusion in the creation of the loading data. Circumstances alter cases and those weak guns may now be in a larger supply, meeting a larger demand. There is loading data in manuals dating from the early 1950s that if used with old, low-strength rifles from the 1870s and ‘80s would very likely take those old rifles apart in one shot. There is now a lot of interest in shooting old cartridge rifles, and the new manuals reflect this interest with data developed especially for them.

There is also the matter of data published in magazines. This is often the work of an individual who has cooked up some handloads that he thinks are pretty good. This is sometimes an amateur working without the benefits of pressure-testing equipment. Magazines publish disclaimers to the effect that any loading data published therein is used at the shooters’ own risk. It is indeed.

Firearms/ammunition expert and author Philip Sharpe received many letters during his career as a technical editor and advisor for the *American Rifleman* magazine. By his assessment, one of the most dangerous types of reloaders was the “instant expert.” This is the person who has read one or perhaps two books on reloading. He has been doing it for a few years and has grown a towering intellect (make that ego) in the process. He has become imbued with an innate savvy of all things firearms related and wants not only to chart new courses in the reloading business, but also to share his “discoveries.” This is the person who, without the aid of pressure-testing equipment or any form of metallurgical analyses, has decided to start experimenting with



The sad end of a fine old rifle—accidentally overloaded with a double charge. (Photo courtesy of Tom Trevor)

improved-performance loads, meaning higher velocities, heavier bullets, and more pressure. How does he know his gun can take these higher pressures? Because it's a Remington, Winchester, Mauser—whatever. More likely, he has a kind of simple faith that his guns possess hidden strength because those companies make their guns tough enough that they can't be destroyed. This is nonsense.

There has yet to be a small arm built that can't be wrecked. Firearm and reloading equipment manufacturers are constantly improving their products to make them safer and easier to use.

Of course, just plain simple mistakes can have disastrous results. One experienced reloader a few years back was reloading ammo for his Ruger No. 1. As he was adjusting his scale, he determined the load he wanted, which was within published limits, needed to be 5/10ths of a grain heavier. So he adjusted the scale, and his powder thrower, to drop 5 full grains more powder, not just 5/10ths, which put his load 4 1/2 grains over the maximum. The result was an action totally welded together. Luckily, the No. 1 has a very strong action.

Probably the best and most succinct list of safety rules you'll find is found in a little folder offered free by the National Reloading Manufacturers Association. It is reprinted here with the NRMA's permission:

## The Basic Rules For Reloading Safely

### Introduction

Most reloaders handload because it is interesting, less expensive than shooting factory loads and because they can often develop more accurate loads for specific guns.

The NRMA wants you to enjoy this hobby safely and this leaflet provides some basic rules observed by all top-notch reloaders. Obviously, it is not a reloading manual. You are urged to read all available books on reloading. Go to demonstrations, talk to experienced handloaders. Make yourself as knowledgeable as you can. Get all the help you can!

### Basic Reloading Precautions

1. Modern ammunition uses smokeless powder as the energy source. Smokeless powder is much more powerful than blackpowder or Pyrodex®. Never substitute smokeless powder for blackpowder or Pyrodex® and never mix it with either.

2. Follow loading recommendations exactly. Don't substitute components for those listed. Start loading with the minimum powder charge in the loads shown.

3. Never exceed manufacturers' reloading data. Excess pressures caused by excessive loads could severely damage a firearm and cause serious injury or death.

4. Understand what you are doing and why it must be done in a specific way.

5. Stay alert when reloading. Don't reload when distracted, disturbed or tired.

6. Set up a loading procedure and follow it. Don't vary your sequence of operations.

7. Set up your reloading bench where powder and primers will not be exposed to heat, sparks or flames.

8. DO NOT smoke while reloading.

9. ALWAYS wear safety glasses while reloading.

10. Keep everything out of reach of small children.

11. Keep your reloading bench clean and uncluttered. Label components and reloads for easy identification.

12. Do not eat while handling lead.

13. NEVER try to dislodge a loaded cartridge that has become stuck in the chamber by impacting it with a cleaning rod. Have a competent gunsmith remove the round.

### Smokeless Powder

All smokeless powders obviously have to burn very fast, but handgun and shotgun powders must burn faster than rifle powders. You will readily note the differences in physical size and shape of various powders, but you cannot see differences in chemical composition that help to control the rate of burning. Burn rate is also affected by pressure. "Hot primers," seating the bullet too deep, over-crimping the case on the bullet, tight gun chambers, oversize bullets, use of heavy shot loads—and anything that increases friction or confinement of the powder—will increase the pressure. Obviously this hobby requires attention to detail, patience and meticulousness to insure the safety and quality of loads produced.

### Powder Warnings

1. NEVER mix powders of different kinds.

2. Use the powder ONLY as recommended in manufacturer reloading manuals.

3. Store powder in a cool, dry place.

4. If you throw or measure powder charges by volume,

check-weigh the charges every time you begin loading, occasionally during loading, and when you finish.

5. Pour out only enough powder for the immediate work.

6. NEVER substitute smokeless powder for blackpowder or for Pyrodex®.

7. Don't carry powder in your clothing. Wash your hands thoroughly after handling it.

8. Store powders in original package. Don't repack.

9. Keep powder containers tightly closed when not in use.

10. Specific powders are designed for specific uses.

Don't use them for other purposes.

11. Smokeless powder is *extremely flammable*. To dispose of deteriorated powders, follow recommendations in The Properties and Storage of Smokeless Powder — SAA-MI Reprint #376-2500, which is published in some reloading guides.

12. Empty the powder measure back into the original powder container when through with a reloading session. *Do not mix powders.*

13. Clean up spilled powder with brush and dustpan; do not use a vacuum cleaner because fire or explosion may result.

#### Primers

Priming materials differ in brisance (initial explosive force) and in the amount of hot gas produced. Don't mix primers of different makes.

1. Don't decap live primers. Fire them in the appropriate gun — then decap.

2. Don't ream out or enlarge the flash hole in primer pockets. This can increase chamber pressure.

3. Over-ignition creates higher gun pressures. The best results are obtained by using the mildest primer consistent with good ignition.

4. Don't use primers you can't identify. Ask your local police or fire department to dispose of unidentifiable or non-serviceable primers.

5. Keep primers in the original packaging until used. Return unused primers to the same package. Don't dump together and store in bulk. There is risk of mass detonation if one is ignited.

6. If resistance to seating or feeding of primers is felt, STOP and investigate. *Do not force primers.*

7. Store primers in cool, dry place. High temperature, such as in a summer attic, causes them to deteriorate.

8. Don't handle primers with oily or greasy hands. Oil contamination can affect ignitability.

9. There have been instances of "primer dusting" in the tubes of loading tools because of vibration. Clean the machines after each use.

10. Refer to SAAMI reprint "SPORTING AMMUNITION PRIMERS: Properties, Handling & Storage for Handloading."

#### Handling Lead

Lead, a substance known to cause birth defects, reproductive harm and other serious physical injury, must be handled with extreme care. Handle lead bullets or lead shot only in

a well-ventilated area and *always* wash hands after handling lead and before eating. Discharging firearms in poorly ventilated areas, cleaning firearms, or handling ammunition also may result in exposure to lead. Have adequate ventilation at all times.

#### Handloading Rifle & Pistol Cartridges

1. Examine cases before loading. Discard any that are not in good condition.

2. Put labels on boxes of loaded cartridges. Identify caliber, primer, powder and charge, bullet and weight, and date of reloading.

3. In handgun cartridges, the seating depth of the bullet is extremely important. Handgun powders must burn very quickly because of the short barrel. They are sensitive to small changes in crimp, bullet hardness, bullet diameter, primer brisance and especially to bullet seating depth.

4. Check the overall length of the cartridge to be sure the bullet is seated properly.\*

5. If you cast your own bullets, remember their hardness, diameter and lubrication affects the ballistics.

6. Plastic cases designed for practice loads (where the bullet is propelled by primer gas only) can't be used for full-power loads.

7. Consult manufacturer regarding disposal of unserviceable ammunition. Ask your local police or fire department to dispose of small quantities.

\* Accumulation of lead or grease in the bullet-seating tool may force the bullet in too far. If the bullet isn't deep enough, it may engage the lands of the barrel when loaded. This will increase the chamber pressure.

#### Reloading Shotgun Shells

1. Select cases that are in good condition. Be sure base wad is intact and the shells are of the same brand and type. Discard any with split mouths.

2. Check the powder bushing to be sure it is correct for the powder weight recommended. Check-weigh thrown powder charge.

3. Check shot bushing for shot charge weight.

4. Shotshell wads differ in their sealing ability. Use the load combination specified in the reloading guide.

5. For Your Safety, Please Note: you *cannot* substitute steel or buffered lead shot in loads recommended for lead shot only. To load steel shot or add buffer materials to lead shot, you *must* use different components and follow *exactly* the instructions provided by recognized authorities.

#### Prevent Missing & Double Charges

1. It is easy to double-charge if you are momentarily distracted. Use a depth gauge to check powder height in shell. A piece of doweling rod can be used as a depth gauge.

2. Observe the powder level of cases placed in the loading block. This is a way to discover any cases with missing or double powder charges.

3. Take care to operate progressive loaders as the manufacturer recommends. Don't back up the turret or jiggle the handle. Don't use a shell to catch the residue when cleaning out the powder train.



# Lead Hazards In the Shooting Sports

by Robert D. Williams, Ph.D.

director, division of toxicology, The Ohio State University Medical Center

LEAD IS AN integral component in the manufacture of ammunition, ranging from a relatively low amount to nearly 100 percent in shot. Lead is also present during bullet casting, reloading, and gun cleaning. Lead interacts with organic matter to produce stable complexes. Specifically, human tissues possess prominent lead-binding characteristics. Thus, with a high degree of accumulation and relatively low turnover in man, concerns over the hazards of lead exposure become apparent in the shooting sports.

Exposure to lead can occur through ingestion, inhalation, and dermal contact. In the general population, the primary route of administration of lead is through ingestion: children eating lead-based paint or drinking water contaminated by lead piping. Individuals involved in shooting sports are exposed to high lead levels through dust inhalation, particularly at indoor and covered outdoor firing ranges, or during bullet casting where inadequate ventilation exists. Although firearm instructors constitute an occupational group at higher risk, studies have demonstrated that even recreational use of small-bore rifles can produce elevated red blood cell lead concentrations and symptomatic toxicity, following a 6-month indoor-shooting season averaging only 70 minutes per week.

Higher air-lead levels have been measured in firing ranges where powder charges were employed relative to ranges where only air guns were used, which in turn were higher than archery ranges. The use of totally-copper-jacketed or solid-copper ammunition has been proposed to decrease shooting range air-lead levels, since most of the airborne lead is vaporized from bullet surfaces.

Natural sources of lead in the atmosphere represent an insignificant risk: providing lead chiefly in its sulfide form, estimated to be half a billionth of one gram per cubic meter of air. Airborne dust from the environment and gases from the earth's crust contribute to the low "background" atmospheric level. Certain areas of the world contain substantially higher than background levels of lead, e.g. cities in industrialized regions where about 98 percent of airborne lead can be traced to the combustion of leaded gasoline. Air-lead levels averaging 660 micrograms/m<sup>3</sup>, which are over one hundred million times greater than normal environmental levels, have been measured at some indoor firing ranges. One analysis of firing range dust samples revealed it was composed of 24 to 36 percent lead. Soil lead is also enriched during shooting.

Acute lead poisoning is rare and usually occurs from

ingestion of lead in soluble form, not sucking or swallowing a bullet—which could lead to chronic poisoning if done long enough. The symptoms of acute poisoning include a sweet metallic taste, salivation, vomiting, and intestinal colic. A large quantity ingested may produce death from cardiovascular collapse. Survivors of acute poisoning frequently develop signs associated with chronic toxicity.

Chronic lead poisoning, or plumbism, is manifest with a variety of symptoms. Initially, the individual is tired and weak due to anemia. Subsequent neurologic problems can develop which encompass irritability, restlessness, convulsions and, in severe cases, coma. Associated gastrointestinal disorders are constipation and a metallic taste. Neuromuscular symptoms include fatigue and muscle weakness. The most serious effect of lead poisoning, which occurs more often in children than adults, is encephalopathy. The early signs of encephalopathy involve clumsiness, irritability, and insomnia, which develop because of necrosis of brain tissue. Lead sulfide may appear in the gums and gingiva of toxic individuals as a blue-to-black line of discoloration termed the Burtonian line.

Toxicity from lead absorbed by the lungs and gastrointestinal tract is cumulative. In circulation, it is primarily bound to the red blood cells. Lead accumulates in soft tissues such as liver, kidney and brain. It can remain in the kidneys for 7 years and in bone for 32 years. During steady state, blood tests are considered the best indicator of relatively recent exposure. Urine tests are also employed, although urine lead concentrations tend to fluctuate more over time. Furthermore, hair may be tested to determine long-term exposure. Chelating agents are used as a treatment to assist in the removal of lead from the body. In the event lead poisoning is suspected, it is recommended that a primary care or occupational physician be contacted.

Assistance can also be obtained through state health and environmental agencies or local poison control centers. The National Lead Information Center (NLIC) may be contacted for general information regarding household lead at (800) 424-LEAD (5323).

Precautions that reduce lead exposure while involved in shooting sports will result in significantly improved health and a more enjoyable sport. Foremost attention should be given to the presence of children. The same exposure to a child relative to an adult results in a much higher total body burden of lead due to the reduced size of the child. In 1991, as a result of a large volume of epidemiological

Exposure to lead can occur when shooting in indoor ranges. Airborne lead particles are inhaled into the lungs and absorbed into the blood.



data, the Centers for Disease Control revised the recommended concentration of lead it considers dangerous in children from 25 to 10 micrograms per deciliter of blood. A number of studies indicate that high blood-lead concentrations can hinder a child's bone growth and can induce neurological damage. Since most young children place objects in their mouths, most lead poisonings in children occur between 1 and 5 years of age. There also tends to be a higher incidence of child-related lead poisonings during the summer months. Children should be kept at a safe distance from any enclosed shooting to avoid breathing airborne lead contaminated dust or soil. Dual cartridge respirators or masks are also advisable. Furthermore, materials which may be laced with lead residue—including cartridge cases, bullets, wads, primers, shot, cleaning patches, and cloths—should be kept out of reach of children.

While cleaning any firearm, avoid contact with bore-fouling residue from oily cloths or patches, which increase the absorption of lead through the skin. Solvents such as Shooter's Choice Lead Remover or Gunslick Super Solvent effectively remove lead from gun bores. Gloves are recommended as a barrier to absorption during cleanup using this or other products. A detergent containing trisodium phosphate, available at most hardware stores, is effective at solubilizing the lead for proper removal from lead-contaminated areas. Measures should be taken to ensure that all areas—as well as tools and accessories of the loading bench, including presses, dies, scales, gauges, measurers, and funnels—are properly cleaned of lead residues. During bullet casting, an adequate amount of ventilation is required. Outside is best since vaporized lead coming off a melting pot will condense on walls and rafters and can be inhaled directly or as dust in cleaning. Smoking and eating is dangerous when handling any lead-based material because of accidental transfer from hands to mouth. After handling equipment and cleaning the area, hands should be washed.



(Above and below) When cleaning firearms, avoid the fouling left on patches. The residue can be absorbed into the skin, so gloves are recommended. Also, be sure to thoroughly wash your hands and the work area when finished.



With adequate precautions, the presence of lead while shooting, reloading or cleaning can be adequately controlled to minimize potential exposure, improving the quality of the sport and the health of each participant. Since toxicity is cumulative, periodic blood tests can provide added assurance for safety.

When reloading, only one component in the load chain is reused over and over.

# The Cartridge Case

**THE ORIGINAL PURPOSE** of a cartridge was to facilitate quick loading and serve as a means to keep those loads consistent. The first cartridges contained charges of powder wrapped separately in paper to speed loading and eliminate the powder horn. These appeared in the late 1550s. It became apparent fairly early in the shooting game that breech-loading firearms were a lot more convenient than muzzleloaders. Soldiers especially liked the idea of not having to stand up to load while being shot at, since this interfered with their concentration. Sometimes they would forget where they were in the process, and would load a second powder charge and bullet on top of the first. At least one such soldier tamped more than a dozen loads into his rifle at the Battle of Gettysburg before tossing it away to look for something better to do than try to extract them. Several thousand rifles with multiple unfired loads were picked up after that battle.

Early self-contained cartridge cases were made of paper, cardboard, linen, rubber, collodion, even sausage skin. All were fired by a separate percussion cap. While they were more or less easy

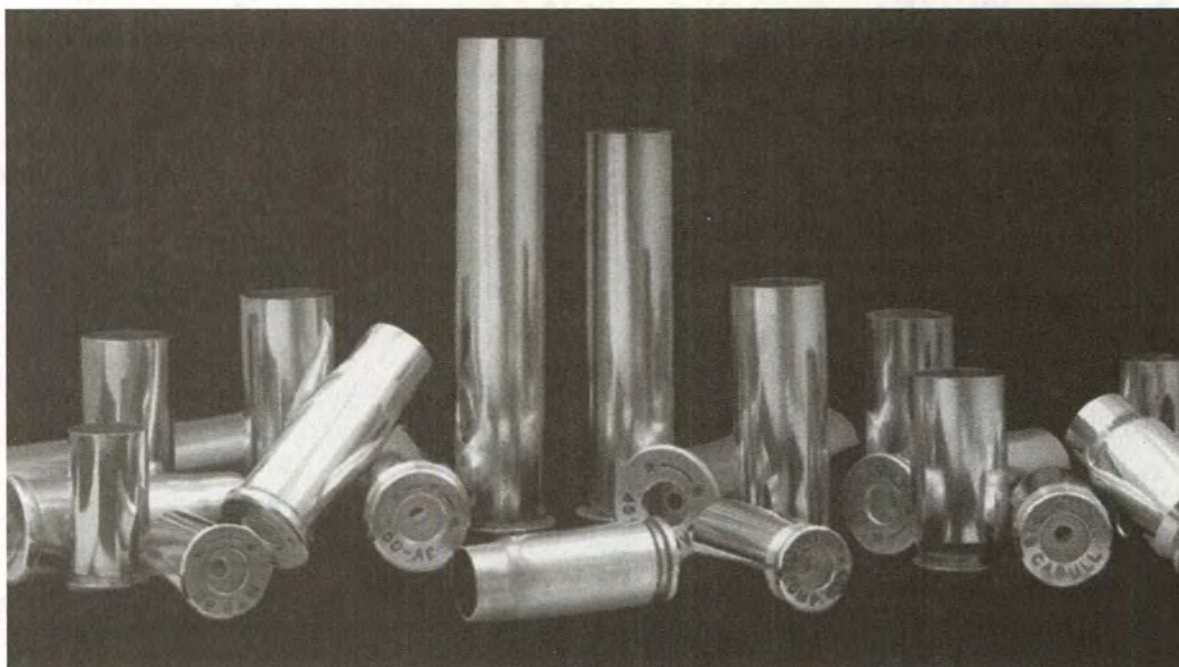
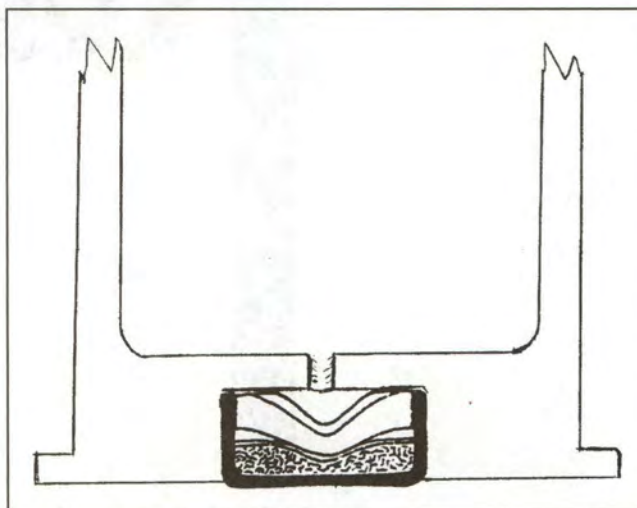
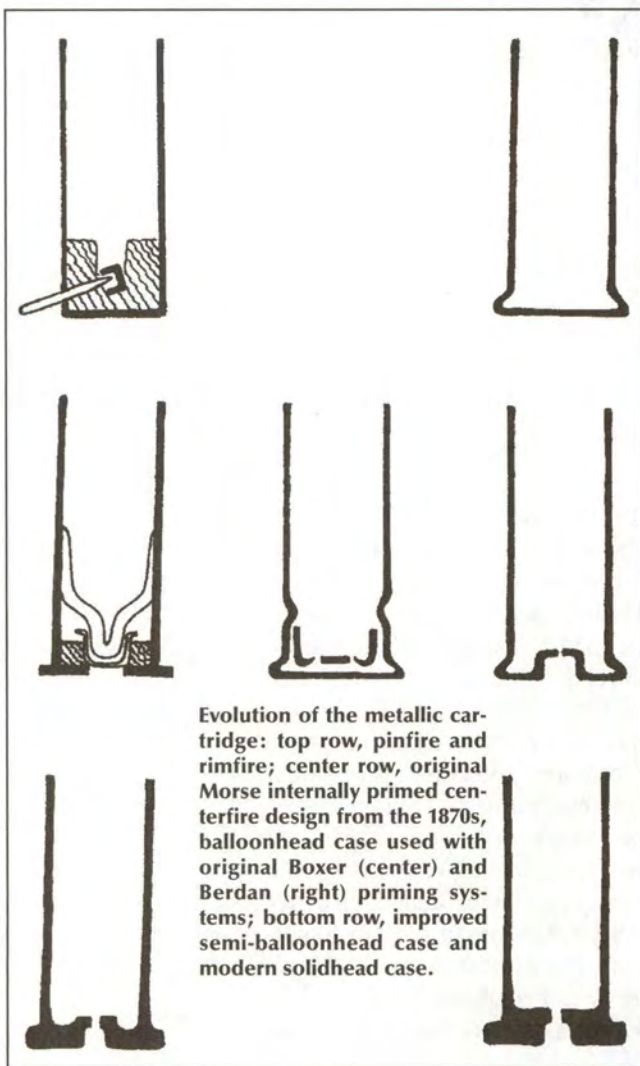
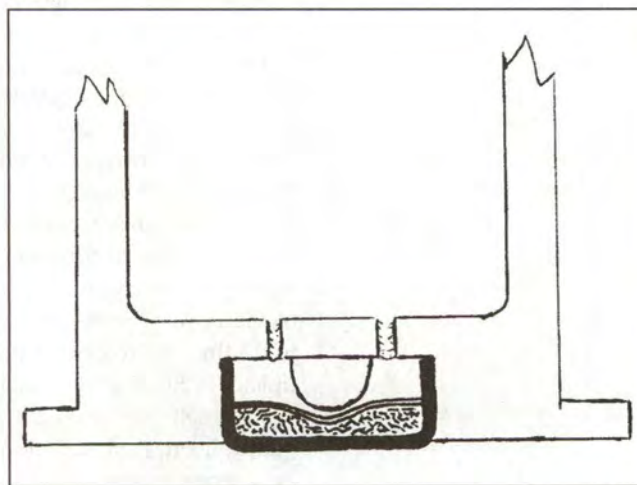
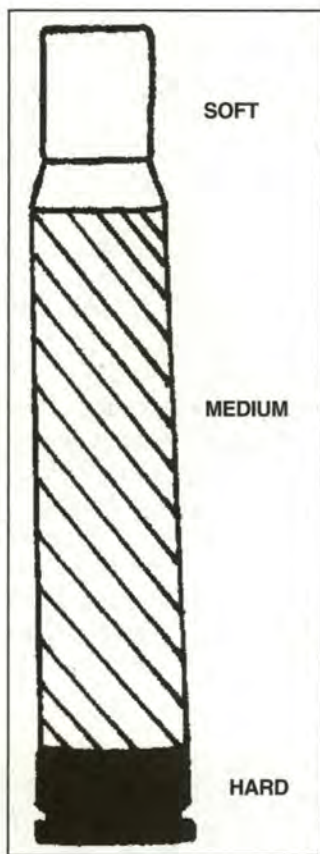

Photo courtesy of Starline Brass



Boxer (above) and Berdan (below) systems are the ones used today.





(Left) The modern brass cartridge is made hard and thick where the greatest amount of support is needed, springy in the body for easy extraction, and soft at the mouth to ensure a good gas-tight seal when fired.

(Right) The parts of the cartridge case.

(Below) The loaded cartridge fits closely, but not tightly, in the chamber. The case swells on firing to make a gas-tight seal in the chamber. After firing, the pressure returns to normal and the case springs back to close to its unfired size for easy extraction.

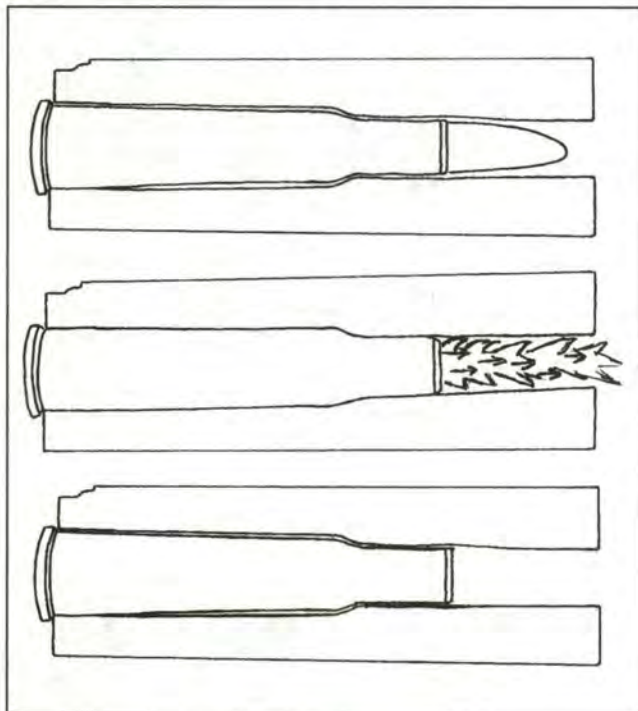

to load, those that went into breech-loading guns still had not solved the breechloader's basic problem of gas leaks. Many attempts were made to deal with the early breechloader's nasty habit of spewing fire and smoke out of the joint between breechblock and barrel into the face of the shooter. The actions also tended to stick and eventually jam when they became encrusted with blackpowder fouling. It was

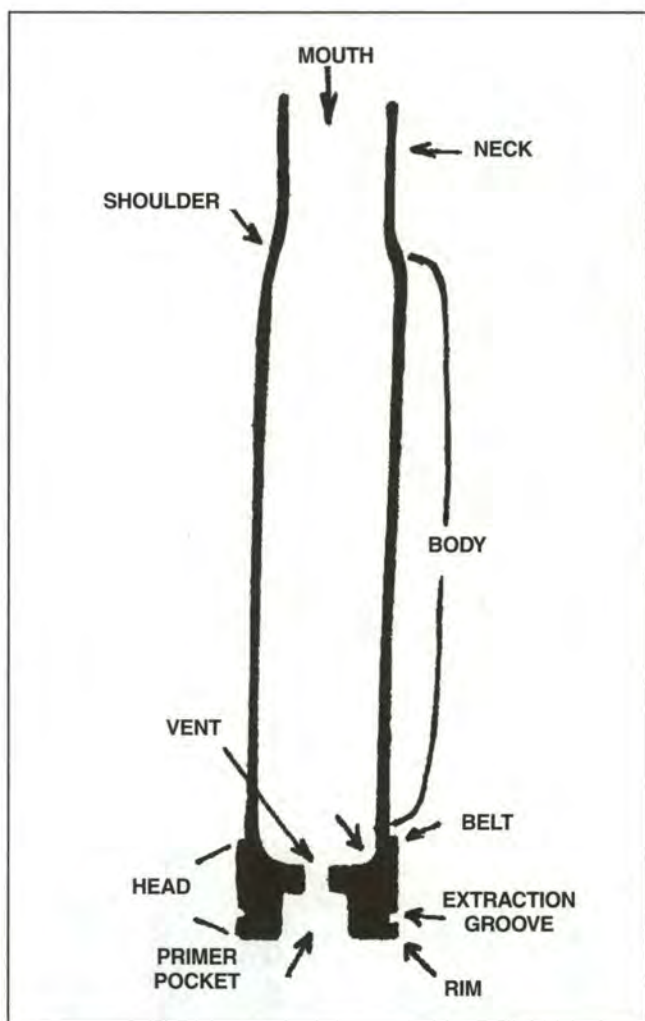

these problems that the metallic cartridge really solved, by closing the breech with a gas-tight seal and containing much of the fouling that wasn't in the barrel. At this point the cartridge became not merely a convenient package-form of ammunition, but an integral part of the firearm. By containing all the gas generated in the firing cycle it made the firearm more efficient. It also made possible the use of heavier charges generating higher pressures than could be used in a non-sealed gun. Finally, it served as a safety device by preventing gases from entering the action and destroying it.

The first commercially successful, completely self-contained metallic cartridge was invented in 1836 by Casimir Lefauchaux in France. The original style had a metal head and cardboard body, much like a shotshell. The primer was fired by a metal pin protruding above the head. The pinfire cartridge, however, had problems: It was not waterproof, and there was some gas leakage where the pin entered the case; the cartridge had to be properly oriented or "indexed" to enter the breech; if dropped it could accidentally discharge; and it was fairly expensive to produce, though it could be reloaded.

The second advance in cartridge design was the rimfire, developed in 1857 by Horace Smith and Daniel Wesson. It was based on the tiny "cap" cartridges patented around 1845, in France, by Flobert. It consisted of a copper tube

closed at one end. The closed end was flattened just enough to create a hollow rim, which contained the priming material. The tube was filled with blackpowder and the open end or mouth was crimped to hold a bullet. The cartridge discharged when the rim was crushed at any point on its circumference by a firing pin. No indexing was necessary. The rim also stopped the cartridge from sliding into the barrel. The rimfire was cheaper to manufacture than the pinfire, was less susceptible to accidental discharge and could be made weather- and water-tight. The first rimfire was the Smith & Wesson Number I pistol cartridge, now known as the 22 Short. Rimfire cartridge cases could not be reloaded. During and shortly after the American Civil War, rimfires were made in sizes up to 58-caliber.

Good small designs, when made large, often don't work. This was the case with the rimfire. The larger sizes had the habit of swelling in the head area when fired if this head was not fully supported by the breech of the gun. Bulged heads jammed revolver cylinders preventing rotation. Solving this problem by making the cartridge head thicker or

harder required a very heavy hammer spring to fire it, which made the gun difficult to cock and resulted in an unacceptably heavy trigger pull. In addition, the amount of powerful priming material in the rims of the bigger cartridges would occasionally blow them off, leaving the tubular body of the case stuck in the chamber.

During and after the American Civil War, dozens if not hundreds of patents were submitted for all sorts of cartridges. One design had the firing pin inside; another was a spin-off of the rimfire, with the entire inside of the base coated with priming compound and held in place by a perforated washer. There were others with heads shaped like champagne bottle bottoms in attempts to overcome the shortcomings of the pin and rimfire designs. The basis of the solution came from George W. Morse who designed a cartridge in 1858 having a solid base with a small, separate primer in the center of the head. The primer fired when crushed against a wire anvil soldered inside the case. Mass production was impractical then, but Morse had overcome the above problems by creating a cartridge that was strong in



All of these rounds are non-reloadable for a variety of reasons. Left to right: The 12mm pinfire could theoretically be reloaded, but no components are available; tiny 230 Morris used a smaller than standard primer (not available), but new cases can be formed from cut-down 22 Hornets; aluminum and steel cases are for one-time use. "Posts" in the aluminum CCI Berdan primer pockets are battered in the first firing. The steel 7.62x39mm and 7.62x54mm Russian military cases are Berdan-primed and difficult to decap, but it can be done. The two darker cases are lacquer coated to make them function through autoloaders. This coating will likely come off in your reloading dies. In short, it's not worth the effort with Boxer brass cases becoming commonly available.



Old copper and soft brass cases from the last century and the early part of this one are a bad bet for reloading. They are often corroded by the blackpowder they contained, by deterioration through exposure to pollutants, or are simply made of poor metal and are too weak for modern smokeless pressures. Examples include, left to right: 22 WCF, 25-20 SS (with a newly-made 25-20 case), 38 Long, 45 S&W, and two 45-70s.



All rimfires are essentially non-reloadable. They range from the minuscule 22 BB Cap (far left) to the 52-caliber Spencer round used in the Civil War.



The REM-UMC case on the left suffered near total separation due to mercury contamination. This same factor caused the one on the right to pull apart in the resizing die.



Blanks are made of substandard brass and often contain flaws, like the 223 case with the star crimp. This crimp, as with the flutes on the sides of the 30-06 dummy round, weakens the metal. These cases would likely split in the reloading die or in the next firing. In short, don't try to use brass from blanks, grenade launching or dummy rounds.

the head where strength was needed, did not require a heavy firing pin blow to discharge it, did not need to be indexed, was not susceptible to accidental discharge and could be made durable and waterproof.

In the 1870s the first really powerful cartridges were produced, based on the Morse design, with center priming and a reinforced head. The problem to be solved at this point was to come up with a design that was rugged, dependable, and that lent itself to ease of manufacture. Various folded and composite head systems were tried with limited success. The heart of the problem was to create a reliable, simple-to-manufacture primer. The problem was solved twice—by Hiram Berdan in America, in 1866, and by Edward M. Box-

er in England a year later. Berdan reduced the Morse wire to a tiny knob in the primer pocket with the priming material in a simple inverted cup above it. The ignition flame entered the cartridge case through two or three vent holes. Boxer crimped a tiny anvil in the primer cup itself with a space on either side to permit the flame to reach the powder charge through a single vent hole in the cartridge case. These are the two systems in use today. Oddly, the Boxer system became the American standard while the Berdan system found favor in Europe. The Boxer priming system with a single vent hole lends itself to easy removal by a simple punch pin, while the Berdan primer must be levered out with a chisel-type extraction tool.

### Why Brass?

Early cartridges were made of copper because it was a soft, easily worked metal that could be formed into complex shapes in punch dies without becoming too brittle and splitting or cracking in the process. It had a high degree of plasticity. Among the copper cartridge's merits were that it resisted the corrosion of blackpowder and early corrosive primers; it was strong enough not to crack under the pressure of firing if well supported; and it formed a good gas-tight seal in a gun chamber. Copper's major failing, however, was low elasticity. When fired with a heavy charge the copper case had a tendency to stick in the chamber of a gun, particularly if that chamber had become hot and dirty with powder fouling.

Brass, an alloy of copper and zinc, possesses strengths and qualities neither element has separately. Most notable are hardness and elasticity. Modern cartridge brass (70 percent copper, 30 percent zinc) is the ideal metal for cartridges, being capable of being hardened and softened by the application of pressure and heat respectively. Thus, the head can be hardened, the body made semi-elastic and the mouth left relatively soft for a good gas seal. Such a cartridge case swells on firing to make a good gas seal in the chamber. After firing, the case springs back close to its original size, allowing easy extraction from the chamber. By the simple expedient of squeezing a fired cartridge case to its original size in a die and replacing the fired primer with a new one, it can be reused. A brass case may be used dozens of times with conservative loads. It is the most expensive component in the cartridge.

Because brass is relatively expensive, compared to other alloys, engineers have been at work to find cheaper materials that will do as well. Steel and aluminum alloy cases have been experimented with since the World War I period. In the last 20 years, advances in metallurgy and coatings have resulted in acceptable quality (for one-time use) steel and aluminum cases. Neither, however, is very suitable for reloading.

In spite of advanced heat-treating techniques, steel cases cannot be made as selectively elastic as those of brass. Steel cases tend to be rather hard and brittle. After a few resizings, the necks split, rendering them useless. To make steel



(Above) Basic cartridge case forms include the following variations, left to right: straight-walled rimmed (45-70), straight-tapered (38-55), rimmed bottleneck (30-40 Krag), semi-rimmed straight (351 Winchester SL), rimless straight (30 Carbine), semi-rimmed bottleneck (220 Swift), rimless bottleneck (30-06), rebated head (284 Winchester), straight belted (458 Winchester Magnum) and bottleneck belted (7mm Weatherby Magnum).

Basic cartridge forms for handguns, left to right: straight rimmed (357 Magnum), straight semi-rimmed (38 ACP), straight rimless (45 ACP), semi-rimmed tapered (9mm Luger), rimless bottleneck (30 Mauser), and rebated head (41 Action Express).



cartridges feed through various autoloading rifle and pistol actions, they are often coated with a varnish-type lubricant to keep them from sticking in the chamber when fired. When resizing these cases, this coating will tend to slough off in the resizing die and thus lose its effectiveness. Steel cases are most often encountered in military ammunition. The most common is the 7.62x39mm cartridge for the SKS and AK-47 rifles. These cartridges, in addition to being made of steel, are Berdan-primed and are thus more difficult to reload. Occasionally some steel-cased ammunition from WWII will turn up in 45 ACP and 30 M-1 Carbine. It is Boxer-primed and can be reloaded, but with good quality American brass cartridges in the above calibers now in

plentiful supply, attempting to reload this stuff isn't worth the effort. Be careful of shooting this ammunition, because some steel-case cartridges loaded with steel-jacketed bullets have been known to rust together, jumping pressures considerably when fired.

Aluminum cases in handgun calibers are manufactured by CCI as their Blazer line. These use a special Berdan primer, unavailable to reloaders, and are specifically marked NR for non-reloadable. Aluminum suffers some of the same problems as copper with its lack of spring-back, though it can be alloyed and heat-treated to make good cases for low-powered cartridges. Aluminum does not hold up well under resizing and crimping, and the cases frequently split on the





**Case failures are not common, but they do happen. The nearer to the case head the rupture, the more serious it is.**

first attempt to reload them. It's not worth the effort when good brass cases are available.

The shortcomings of various early types of cases have already been mentioned, but a few points should be added. Pinfire guns and ammunition are totally obsolete; neither was made in this country and there is no reloading equipment or data available for these. Rimfire cases are primed with a wet mixture spun into the hollow rim. Owners of obsolete rimfire guns have a few of options: 1) Search for ammunition through such dealers as The Old Western Scrounger, or large local dealers who may have some in stock; 2) Polish them up and hang them on the wall.

Early centerfire cartridges are usually far too valuable as collectibles to shoot. Old cases, however, are still around and often are the only source of ammunition for some obsolete and foreign guns. Some of these cases are available from specialty suppliers and manufacturers. If vintage cases have been fired with blackpowder they are nearly always badly corroded and not safe. Copper and soft brass cases of the old balloon and semiballoon-head construction, from the last century, are too weak for use with modern smokeless loadings. Centerfire cases from the 1920s through the 1940s that have been contaminated by mercuric primers are very dangerous and should not be reloaded. This problem will be addressed in the chapter on primers.

Finally, a final word about blank cases. Even with the powder removed, these are not fit for reloading. Blanks are made from substandard cases not capable of meeting pressure and dimension standards for full-power ammunition. Attempting to remove the crimp in such a case usually splits the mouth and it's finished. The same is true for dummy cases, which contain a bullet and no powder or primer, and have flutes in the case body.

### **The Modern Brass Case**

As firearms technology has advanced, guns have become more powerful and sophisticated. Cartridge case design has had to keep pace with this evolution. In reality, cartridges are often designed first and then guns are designed or adapted to fit them.



**This 45 ACP has been so badly battered that it will probably not go into the resizing die. The split in the body of the 22 Hornet probably resulted from too many reloadings. The tiny split on the mouth of the 44 Winchester (center) could be easily overlooked. All are rejects.**

The basic design of the contemporary centerfire cartridge case can be one of a number of variations. The case can be: 1) straight-walled rimmed. These date from the 19th century, and include the 32 and 38 S&W revolver cartridges, the 45 Colt and the 45-70 rifle. They also include modern cartridges such as the 38 Special, 357 and 44 Magnums; 2) straight-tapered. An effort to improve extraction led to this design. It is now nearly obsolete, the 38-55 being the only current survivor; 3) rimmed bottleneck. These include late 19th century smokeless powder cartridges such as the 30-30 and 30-40, 303 British, and 22 Hornet; 4) semi-rimmed straight. These include currently-made 32 Auto and 38 Super Automatic cartridges. The semi-rimmed design was to facilitate feeding through box magazines, with a slight rim to keep the cartridge from entering the chamber; 5) semi-rimless bottleneck. Now rare, the 220 Swift is an example; 6) rimless straight. A common example is the 45 ACP; 7) rimless tapered. These are the 9mm Luger and 30 M-1 Carbine; 8) rimless bottleneck. This is an improved smokeless design from the 1890s. Most modern rifle cartridges use this design; 9) rimless belted. This design is used only on high-pressure magnum rifle cartridges such as the 458 Winchester Magnum; 10) rebated head. This one has a rimless head smaller than the body permitting a slightly increased case capacity. Examples are the 284 Winchester and 41 and 50 Action Express.

### **Case Selection**

When buying cartridge cases for reloading, the first thing you want to be sure of is that you have the right one for your gun. Most civilian guns have the caliber marked on the barrel. Military arms, however, are not so marked, at least

not very often. When in doubt, have the gun checked out by a good gunsmith. If there is no question about caliber, you want new or once-fired cases from a reputable source, marked with the headstamp of a known manufacturer and not from the "Royal Elbonian Arsenal." Military cases, referred to collectively as "brass," are often sold at bargain prices. Sometimes they are a bargain if they have been fired only once and are not battered up by being run through a machinegun. The best military ammunition bargains are loaded rounds bought in bulk. That way you shoot it first. Military cases do, however, have a few drawbacks. Assuming they are not Berdan-primed, they may have been fired with corrosive primers. A wash in hot water and detergent will remove corrosive primer salts after firing.

The main problem with military cases is the crimp holding in the primer. Removing this crimp means a heavy-duty decapping pin and either chamfering the primer pocket or removing the crimp with a primer pocket swage die, as explained in Chapter 10, "Rifle Cartridge Reloading".

With the exception of new unfired cases in the box, all brass should be given an initial inspection. Bulk, once-fired, military and commercial cases may have loose debris, including primers (live and dead), rattling around inside

them that should be removed. Cases should be sorted by manufacturer and kept in separate containers. Although the dimensions for all cases are basically the same, internal dimensions (caused by varying wall and head thickness) and the size of the vent in the primer pocket will vary. Mixed cases will yield different pressures and velocities, giving less accurate shooting. Varying pressures can be dangerous if the load you are using is a maximum one. If, for instance, this load is worked up using one type of case with a fairly thin wall and thus a comparatively large internal capacity, in combination with a small vent, the internal pressure will be significantly lower than one with a thicker wall, smaller capacity and larger vent, which will be significantly higher.

Beyond separation by manufacturer, cases should be checked for splits in the neck, corrosion and any anomalies indicating pressure or headspace problems (meaning case stretching) or serious battering in the firing process that would render them unreloadable. Oil, grease, grit and dirt should be removed before reloading.

### Reading Headstamps

The headstamp markings of cartridge cases contain valuable information that will prove useful when buying ammu-

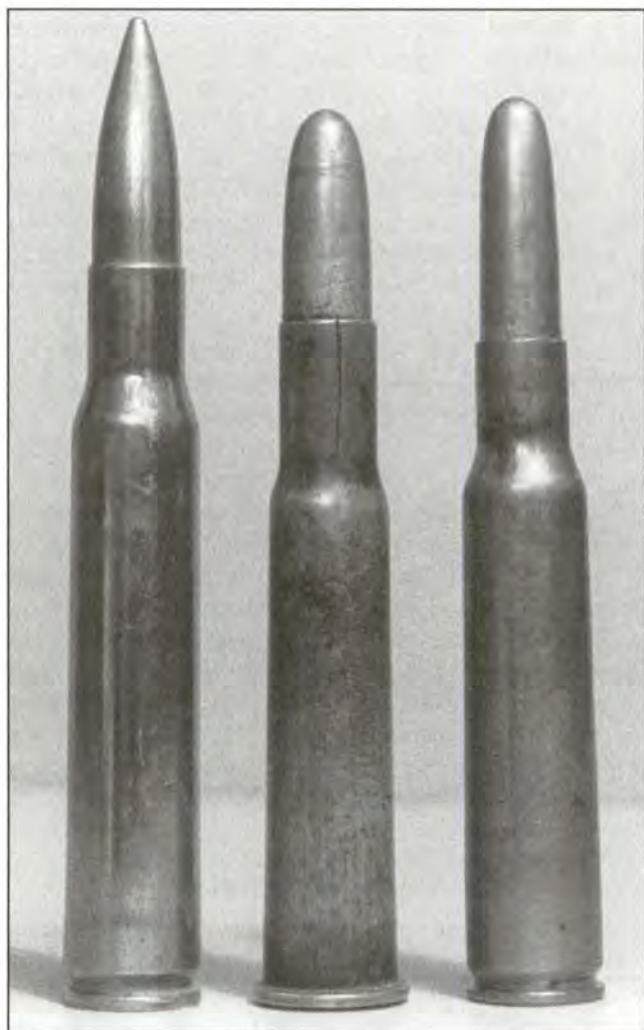

(Above) Manufacturing defects, in this instance what appears to be poor brass, resulted in split necks in these 223 military cartridges.

Season cracking (deterioration through exposure to pollutants in the air) caused this 1904-made 30-40 Krag case (center) to split at the neck. The 7mm Mauser round (right) has hairline cracks in the deep tarnish at the shoulder. The 30-06 (left), made at the Frankford Arsenal in 1905, benefited from the advantages of good storage and is in near-perfect condition.



What headstamps tell you. Commercial ammunition is marked with the caliber and name of the manufacturer, at least in this country. Military ammunition is usually stamped with the code of the arsenal or manufacturer and the date of manufacture. Top row, left to right: a 45-70 current headstamp, pre-WWII commercial Winchester and Remington headstamps (good candidates for being mercuric primed), and an inside-primed military centerfire from the 1880s. R indicates a rifle load, F is the code of Frankford Arsenal, 2 82 indicates it was loaded in February, 1882. Bottom row: a 30-40 Frankford Arsenal round loaded February, 1904, and a Spencer 52-caliber rimfire made by the Sage Ammunition Works.

munition and empty cases. Commercial makers mark their cases with their name or trademark, the caliber and name of the cartridge, e.g., WW 45-70 Govt. This tells you it was made by Winchester/Western and it is the 45-70 Government cartridge (originally made for the 45-caliber Springfield army rifle).

Markings on cases made for the military contain similar information, and sometimes a two-digit date of manufacture. LC is the Lake City Ordnance Plant; WRA is Winchester Repeating Arms Co.; RA is Remington Arms Co. A stamp of RA 79 indicates Remington made the cartridge in 1979. American military cases are not marked by caliber. Early cases made at the Frankford Arsenal in Philadelphia were marked, for instance, F or FA 3 05. This indicates the source and the month of manufacture (March) and the year 1905. This is not ammunition you would want to shoot, especially if it shows any sign of corrosion. American-made military ammunition used corrosive priming into the early 1950s. Different arsenals switched to non-corrosive priming at different times with all being changed over by 1954. Non-corrosive priming will require less cleaning of your gun.

### Case Cleaning

Most shooters like to keep their cases shiny and bright. They look better and are easier to find on the ground.

Shined cases are less likely to collect dirt and grit and can be easily checked for damage caused by corrosion. Dirty cases can hide flaws that may run deep.

There are two basic methods of case cleaning. The first is a wet process that uses a concentrated, acid-based cleaner that is mixed with water. This must be done in a glass, plastic or stainless steel pan. Warming the pan with the cases in the mixture speeds the process. The cleaned cases must be rinsed to remove all residue and then oven-dried on "warm." Too much heat can ruin the heat-treatment of the cases. Cases should be decapped before wet cleaning.

Dry cleaning is by tumbling the cases in an abrasive cleaning media that's usually made of ground corncobs or ground walnut shells. This requires a motor-driven tumbler or vibratory tool into which the cases and media are put for cleaning. Once cleaned, cases must be wiped free of dust and any media trapped inside must be removed.

### Cartridge Case and Ammunition Storage

"Store in a cool dry place" is good advice for keeping just about anything, but this isn't always possible. Depending on one's paranoia and/or notion of thrift, the decision may be made to buy a large quantity of cases. Sometimes quantity simply accumulates in the form of various loadings, always expanding with the addition of new guns to a shooting bat-

tery. Ultimately the questions arise about how long this stuff will last (both cases and finished ammunition) and how do I take care of it?

The shelf life of modern ammunition (both commercial and good handloads) is virtually indefinite if kept under ideal conditions-sealed, cool and dry. Most of us don't have this kind of storage. Experts have preached since time immemorial about the avoidance of heat and dampness when storing. Actually, heat and moisture by themselves don't do all that much damage to quality ammunition. Heat does drive off volatiles in lubricants and propellant powders, and to a degree accelerates powder decomposition. Heat and dampness together are most injurious because water absorbs pollutants and heat accelerates chemical reactions

between these pollutants and ammunition. The triple threat in airborne pollution consists of acids, ammonia, and sulfur compounds. All occur naturally in the atmosphere in addition to being man-made pollutants. They are also found in a variety of household products.

It has been said that certain metals crystallize and become brittle with age. Professor Bryan Wilde, a metallurgist and director of the Fontana Corrosion Center at Ohio State University, said this was not the case. Cartridge brass has a crystalline structure. When exposed to pollutants in the atmosphere, notably ammonia, a breakdown of the alloy begins as the ammonia dissolves the copper. Acids in the atmosphere dissolve the zinc in a process known as "dezincification." In areas where the metal is stressed, like case



**Liquid case cleaners contain a mild acid and require no more equipment than a stainless steel, plastic or glass bowl to soak them in. Cases should be decapped before cleaning and either air-dried or oven-dried at no more than 150° Fahrenheit.**

necks, shoulders and crimps, the crystal edges are farther apart, thus speeding the breakdown in a process known as season cracking. Season cracking begins as tarnish, gradually turning into deep corrosion which often follows the edges of the crystals, giving the surface a frosted appearance, leading to the impression the metal is changing its structure. This phenomenon was first noted in 19th century ammunition used by the British

in India, where it was exposed to the ammonia-rich fumes of cow dung and urine in a hot, humid climate.

Salts, though direct contamination, are another hazard. They occur in perspiration and are a problem mainly because they are hygroscopic—they draw and hold water, which combines with the salt to corrode the metal.

Sulfur, notably sulfur dioxide (SO<sub>2</sub>), causes tarnish when it combines with lead and copper to form sulfides. When SO<sub>2</sub> combines with water (H<sub>2</sub>O) the result is sulfuric acid (H<sub>2</sub>SO<sub>4</sub>). Lead and lead alloy bullets are subject to damage mainly from acids. These attack lead, causing a hard white oxide crust to form, which, in rimfire ammunition, may make it impossible to chamber. Generally, the powder coating on bullets is not a problem, but it does indicate old or improperly stored ammunition/bullets. Unless the coating is excessive, such

**Vibrator/tumbler case cleaners use ground corncobs or ground walnut shells to clean cases through abrasive action. This is probably the best system for cleaning large batches of cases.**



ammunition should be safe to shoot.

Pinpointing the exact reason why a particular batch of ammunition went bad is a mystery to be solved by an expert metallurgist-detective through chemical analysis and examination of cartridge surfaces with a scanning electron microscope. Manufacturers continue to come up with better priming, powder, lubricants, case materials, sealants, and packaging. What you buy represents the maker's state of the art combined with his sense of economy at the time the product was made.

Plating cases with nickel and plating or jacketing bullets with copper inhibits corrosion by acid. Non-hygroscopic bullet lubricants keep moisture away from bullets and out of case interiors. Paper boxes absorb moisture but are generally not a problem if kept dry. This boils down to the fact that if the cases/ammunition are in good shape when put away, and if kept dry and cool, they will last for years, probably decades.

A second problem that still crops up is brittle brass. After cartridge brass is formed it gets a final heat treatment called stress relief. This process involves less heat than annealing and is done to bring the brass to the optimum degree of springiness. Occasionally, a batch will get through that is improperly treated. It will perform fine when new, but after a number of years the brass will have returned to its original brittle state. This is exacerbated by the process of firing and resizing. Cases will split and sometimes burst. Any corrosion taking place will hasten this process. One advantage of the old copper cases was that they were less subject to corrosion and stress changes since they were softer to begin with.

Beyond cool and dry there isn't much to be added regarding shelf storage. For the longest run the best means is a military ammunition can with a rubber gasket, along with a fresh packet of desiccant. The can should be closed on a dry day and opened as infrequently as possible. If ammunition is stored in a can or tightly sealed cardboard container, don't break the seals (letting in pollutants) to have a look. Second floor rooms are perhaps the best for shelf-stored ammunition, avoiding attic heat and basement moisture. Cartridges should be stored away from cleaning products containing ammonia, bleaches, or acids. If it must be stored in a basement, run a dehumidifier and keep it off the floor. It is a good idea to make periodic checks of shelf-stored ammunition in non-sealed boxes—twice a year is fine—to inspect for case tarnish or a haze of white oxide forming on lead bullets.

To the above might be added a list of dumb things not to do. Slathering a gun with Hoppe's No. 9 may do well to keep



Plastic boxes are good for case storage and do a good job of keeping moisture and pollutants out if they're closed on a dry day and kept closed. The cases should always be identified by maker, caliber and number of times reloaded.

it from rusting, but if this is the one kept for home defense the ammonia in the Hoppe's will spread onto the cartridges in the gun and eat right into them. The same is true for any ammonia-bearing solvent cleaner. A rust inhibitor such as WD-40 spray may work preservative magic, but WD-40 is designed to penetrate and will do so in the seams between primers and cases, eventually working into the priming compound and neutralizing it. Leaving cartridges in leather belt loops may look nifty, but if the leather has tanning salts or acids in it these will eat into the metal, etching a ring which adds nothing to the looks or strength of the case.

It should not be forgotten that cartridges are interesting and people can't seem to keep their sweaty hands off them. Ask any collector how often he wipes down his collection after showing it to friends. To prevent damage, two suggestions passed on by collectors are to treat specimens with a light coat of rust-inhibiting grease or liquid car wax. These are the best defense against repeated attacks of finger-borne corrosion. Like the guy at the gas station used to say, "Rust never sleeps."

### Case Failures

In the 19th and early 20th century, case failures were an expected hazard. Today, however, the "headless" or "broken" shell extractor, once found in every shooting kit, has gone the way of the stereoscope and flatiron. Yet failures still happen and they will to you if you do enough shooting.

The quality of today's metallic cartridge ammunition is superb. Nearly two generations of shooters have grown up since the last corrosive, mercuric-primed, centerfires van-



Plastic boxes are best for ammunition storage and usually come with data cards.

The old saying that lightning doesn't strike twice in the same place is just as false in cartridge case failures as it is in meteorology. The low overall incidence of case failures might lead to the belief that the one that failed was simply one bad case. Sometimes it is. If the problem rests with a defective component, given the consistency in today's ammunition, that problem may run through a case-sized quantity, possibly an entire production lot, or at least until someone in quality control realizes there is a problem and does something about it.

### Split Necks

By the same token, if one case from a particular box or purchase-lot that you have been reloading develops a split in the neck, it has become brittle from resizing and the rest of the lot should be checked for the same problem. A split neck is a common failure and not dangerous to gun or shooter. Discard cases so afflicted. They are not fit to reload.

### Body Splits

These are far more dangerous, with the degree of danger increasing in relation to the closeness of these splits to the head of the case. The worst instance is a separation at the case head. This allows high-pressure gas to come rushing back into the action of the gun and into your face, often damaging both. Since eyeballs and eardrums are less robust than a rifle receiver, it is imperative to wear eye and ear protection when shooting.

### Longitudinal Splits

These can be a gun-related problem, namely an oversize chamber. If this is the cause, you will notice swelling of the cases and difficult extraction with normal commercial loads long before you get an actual split. If your gun is bulging cases, stop shooting! Have the gun thoroughly checked out by a very competent gunsmith. Rebarreling may be the only solution. If a case suddenly splits with a load you have been using successfully with other brands of cartridge cases, this is likely an instance of poor-quality, brittle brass. If there is visible corrosion inside and/or outside, corrosion may have helped weaken the case. Throw these away.

ished into the mists of erosive smokeless powder, and not a moment too soon. Case failures these days with new factory centerfire ammunition are virtually nonexistent.

It is in the business of reloading ammunition that most problems occur. Here, the reloader becomes the manufacturer and you must become your own quality control expert. In this role you must learn to recognize all the signs that may lead to an accident, and become an expert at "reading" cartridge cases. This is by no means as easy as it might appear, since similar failures may come from a variety of causes. Flattened, cratered and punctured primers, and gas leaks around primers, are generally signs of excessive pressure. Soft primers, stretched primer pockets caused by multiple reloading or a poor fit of the primer, however, can produce signs similar to high pressures. Swelling of the case head, often accompanied by the brass flowing back into the extractor port are signs of high pressures, but can also be caused by soft, poorly annealed brass. Splits in cases around the head can indicate excessive headspace, which is a gun problem. Similar splits can also indicate inferior brass that contains oxides and impurities, and is sometimes recognizable by its scaly appearance. Internal corrosion from blackpowder loads or corrosively primed smokeless loads can also produce such splits. Improperly annealed brass, in this instance too hard and brittle, or brass made brittle by mercuric primers, or stressed by excessive resizing, will also show problems. That's a lot to consider in one bite, so let's move a bit slower here.

## Circumferential Splits

These may be caused by poor quality, brittle brass, or brass made brittle by mercury contamination. Again, stop shooting!

If this has not happened before with other makes of case and suddenly happens on a different make or lot, it is likely caused by the above. This situation can also result from excessive headspace that is, in effect, a chamber that is too long. Chambers don't suddenly grow longer. If this is a headspace problem there will be warnings before such a separation occurs, namely stretch marks on the case as it gradually pulls apart over the course of several firings. These will often appear as bright rings and will be found on all the cases you fire in that particular gun. They will be most apparent on higher-pressure loads.

## Head Separations

These can be more or less disastrous depending on how well your gun is engineered for safety, namely in terms of gas-escape ports. These allow gases flowing from the chamber, back into the action, to be directed sideways and not into your face. Contamination from mercuric primers is a likely cause of this since most of the mercury will contaminate the case area nearest the primer. Stop shooting! This batch of cases, from that box or lot, identified by the head-stamp markings, is not fit to shoot. Mercury contamination is invisible and the cases look fine until fired. Since mercuric priming was limited to non-military ammunition made from about 1928-1945 there is not that much around any more, but it can still turn up. At times these contaminated cases

will pull apart in the resizing die. This is a definite warning.

## Stretched Primer Pockets

These occur after many reloadings. They are identified by gas leaks (smoke stains) around primers and by primers seating very easily, sometimes by thumb pressure alone. It's time to junk those cases when these signs appear. Excessively high-pressure loadings can also cause these symptoms. This is why maximum loads should only be worked up with new or once-fired cases. With a new case and a heavy load, such leaks tell you to stop shooting!

Primers flattened on firing also indicate high pressure, as do those that are cratered around the firing pin mark, or pierced. If these signs appear with a max load -- stop shooting! If they appear with a loading that has not produced these signs with other primers, the reason is most likely a soft primer.

## Swollen Case Heads

This is nearly always a sign of very high pressure, but can also be caused by a too-soft head that was poorly annealed. If you are working up a max load, excessive pressure is the likely problem. Stop shooting! If this occurs with a load that has given no such indications and you have changed to a different make or lot of case it may be a case problem. Excessive pressures are the main culprit, and are additionally identified by cases stretching lengthwise and picking up machining impressions from the chamber walls and breech or bolt face. Such cases will stick tight to the chamber wall and give hard extraction, a definite sign of excess pressure.



In the last century, the headless shell extractor was a necessary part of the shooter's kit, given the poor quality of the cartridge cases.

Too much of either of these could be a serious problem, possibly leading to serious injury -or worse.

# Understanding Pressure and Headspace

**GUNS FUNCTION BECAUSE** gunpowder burns rapidly to generate tremendous pressure as it is converted from a solid into a gas. This is a process called deflagration. Gunpowder burned in the air burns far more slowly than in the chamber of a gun. Inside the chamber, increasing pressure accelerates burning. As pressure increases the powder forms a churning mass.

The firing sequence begins as the primer ignites the powder. The primer contains a tiny amount of very high explosive that burns with a rapidity that far exceeds that of gunpowder. While gunpowder burned in the open produces a faint whoosh as the gas dissipates into the atmosphere, priming compound burns so quickly it will explode with great violence. This is why explosives such as priming compound, TNT, PETN, etc., are unsuitable for use as propellants. They burn so fast that before a bullet could begin to move down a gun barrel these compounds have burned completely, generating so much gas, so quickly, that for all intents the bullet is simply a plug in a closed container and the gun has become a bomb.



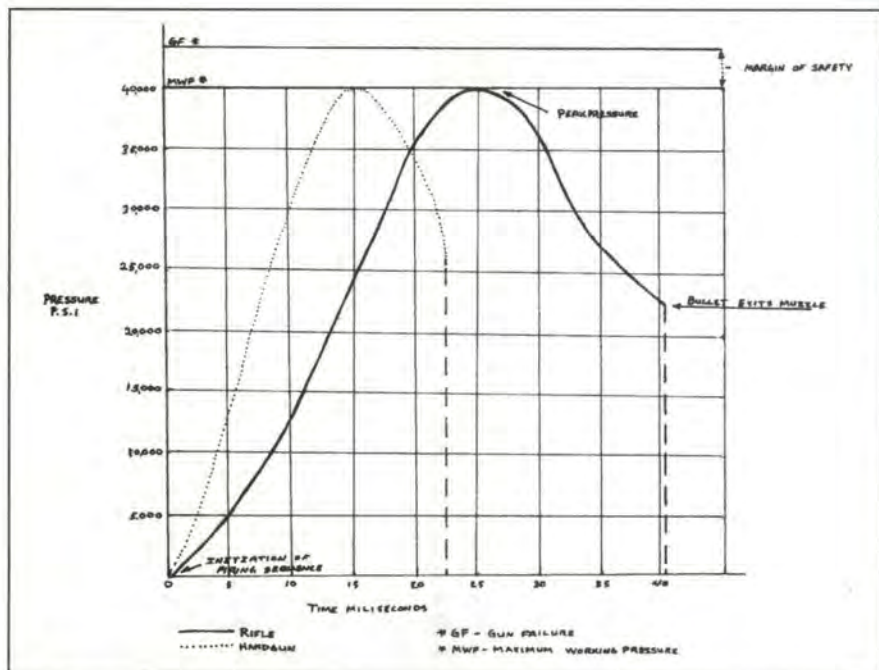

The time-pressure curve starts at the point of ignition. In a few milliseconds, the event is over. The peak pressure is reached as the bullet is an inch or so forward of the chamber. After it has been swaged into the rifling, pressure declines and drops to zero as the bullet exits the barrel. A fast-burning pistol powder in a short barrel develops a sharp curve (broken line), while a slower rifle powder in a long barrel is flatter. The peak of the curve touches the maximum working pressure (MWP) line on a maximum load. Above this is a margin of safety area, and further above that is the point of gun failure.

The priming compound thus serves to get the powder burning. It functions much like burning balls of paper thrown into a pile of dry leaves to get the pile blazing. By throwing a greater number of fire balls into the leaf pile it will be set alight faster and more evenly than if only a few are tossed on. A magnum primer represents a high saturation of fire balls by comparison to a regular primer. By starting the fire in more places at once, the mass of powder is burned more rapidly and completely. More rapid and complete burning will generate more gas and higher pressure.

To continue the bonfire analogy, a fast-burning powder could be likened to dry leaves while a slow burning powder is more like a pile of twigs or wood shavings. The twigs take more/hotter fire balls to get them burning, but they will burn longer than the leaves and generate more hot gas more slowly. The fast-burning powder is ideal for a short-barreled gun. The rapid burn releases gas quickly, generating a high-speed movement of the bullet quickly. This sudden release of gas produces a relatively high pressure in the chamber. Therefore only a limited amount of such a powder can be used without generating dangerously high pressures.

A slow-burning powder can be loaded in greater amount. By virtue of releasing more gas at a slower rate, this works well in long barrels where the burn time is extended by the length of time it takes the bullet to travel to the end of the barrel. The slow-burning powder keeps on generating gas throughout the length of time it takes the bullet to exit. The long burn thus generates lower peak pressure and keeps the average pressure up for a longer time. Once the bullet has passed out the muzzle, further burning is pointless.

This burning process is best illustrated in what is called



The primer is the sparkplug that starts the powder burning. Magnum primers contain more compounds and additives such as aluminum, which becomes white-hot sparks blown into the powder to give the charge even ignition. (Photo courtesy of Speer.)



The flash hole on the case at the left was deliberately enlarged to burn a compressed blackpowder load. If this case were loaded with smokeless powder, dangerously high pressures probably would be generated.

the time-pressure curve. A fast-burning powder such as Alliant Bullseye is intended for handguns and produces a typically short, sharp curve. A slower-burning rifle powder such as IMR 4320 produces a longer, flatter curve in a rifle-length barrel.

Of most critical interest to the reloader is the peak pressure generated by a particular load, for it is this peak pressure that will act as a hammer blow to your gun and wreck it if the peak pressure exceeds the elastic limit of the barrel/action. This will cause it to swell and eventually burst. To keep both guns and shooters from harm, arms and ammunition manufacturers design their products for a maximum working pressure. This is below the failure point by a margin of safety. Loading above this maximum working pressure will drastically shorten the life of a gun and place the shooter at significantly higher risk of a catastrophic failure every time such a load is fired.

Beyond the strength of the barrel and action, working pressure is limited by the strength of the cartridge case. The modern alloy steel in today's rifles make them capable of withstanding peak pressures of well over 100,000 pounds per square inch (psi). Even the strongest brass cartridge cases are not capable of withstanding more than 50,000 to 60,000 psi, and at pressures above that, they will swell, distort or even flow, until an unsupported point gives way and gas escapes, often wrecking the gun. Most cartridge cases are intended for pressures well below these figures.

The most obvious means of raising pressure in a barrel is to put more powder in the cartridge. This also holds true for generating higher velocity. Higher velocity means flatter shooting with less rise and fall in a bullet's trajectory,



The balloon-head case on the 38 Special at left offers more powder capacity, and thus lower pressure. However, this is a weaker design than the solid-head 357 Magnum case on the right.

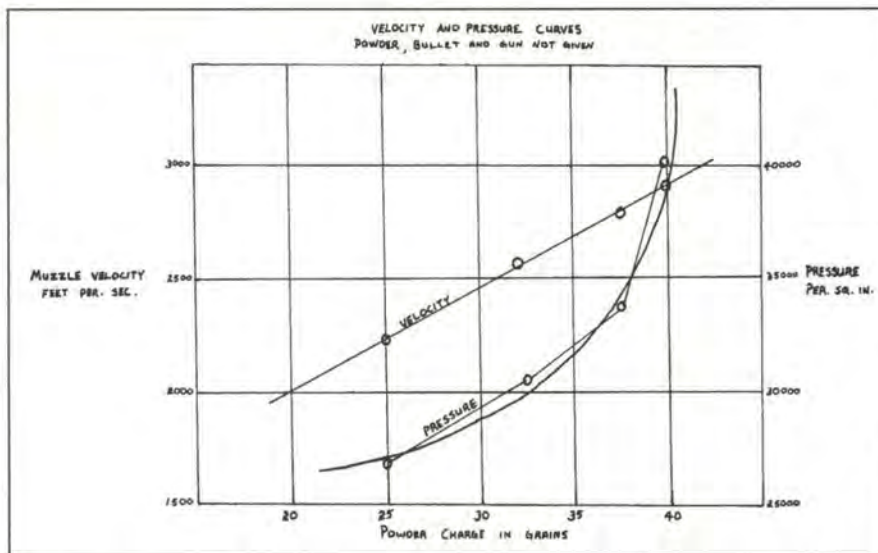

(Above) The pressure-velocity curve illustrates the relationship between velocity and the pressure generated by adding more powder. As powder is added, more of the energy of the expanding gas is worked against the chamber walls and the gas against itself. Additional powder added at the top end of a load generates little additional velocity but considerably more pressure.

The same cartridge with different internal dimensions. The smaller capacity case will generate higher pressures with the same load. Some brands have thicker (or thinner) walls, meaning different capacities. Sort your brass by maker.

and thus hitting a target at an unknown distance is made easier—ask any varmint shooter. The downside to such high-velocity loadings is the generation of very high pressures. An interesting phenomenon some shooters may not be familiar with is that as loadings are increased for greater velocity, pressures begin to go up at an increasingly higher rate. This can be most clearly expressed in what is known as the pressure-velocity curve. In conventional smokeless powder firearms, there is a ceiling on the velocity that can be achieved. This is because at a certain point, as the bullet is made smaller and lighter to achieve higher velocity, the base of that bullet has less surface area to be worked upon, and the gas in the chamber is working against the chamber walls and the molecules of gas against one another. This velocity ceiling is in the range of 11,000 feet per second (fps), and has been achieved with a steel ball blown out of a smooth-bore barrel—hardly practical. The pressure and heat generated at velocities of 5000-6000 fps will wash the rifling out of a barrel in a very few shots. A little over 4000 fps is the maximum practical velocity that can be expected to produce a reasonable barrel life—a span of a thousand shots at the very least before accuracy degrades to a marked degree. Thus, the quest for high velocity is at the cost of shortened barrel life and greatly increased pressures as the top end of the maximum working pressure is reached. This is where the last few additions of powder produce far more pressure than they add in velocity.

### Other Factors Affecting Pressure Reduced Loads

Small loads of certain slow-burning powders, well below

those recommended in loading manuals, have apparently generated very high pressures. Called detonation, this phenomenon may be caused by what has been termed the log jam effect caused by the position of the powder in the case, wherein the powder charge is forward in the case. Powder ignited in the rear slams the rest of the charge into the base of the bullet and the shoulder of a bottleneck case, resulting in a solid plug. As burning continues, pressures jump and a bomb effect is created.

The problem with this theory is that it has been very difficult to duplicate such events in the laboratory. Undoubtedly, a certain number of supposed detonations were instances of bullets fired from such reduced loadings sticking in rifle, or more likely, revolver barrels. The unwary shooter fires a second shot and this bullet slams into the one stuck in the barrel with unhappy results. Whatever the reason, there have been a significant number of accidents involving reduced loads of slow-burning powders. Thus, it is prudent not to experiment below the starting loads listed in the manuals.

With faster burning powders, it has been noted that the position of the powder charge in the cartridge case in less than full caseloads will affect pressures. If the charge is at the rear near the vent, pressures will be higher since a greater amount of powder will be ignited and is not blown out the barrel. With the charge forward, as when the gun is fired almost straight down, pressures may be lower by more than 50 percent.

### Primers

Primers are the fire-starters that get powder burning. The more efficient ones, like magnum primers that burn longer

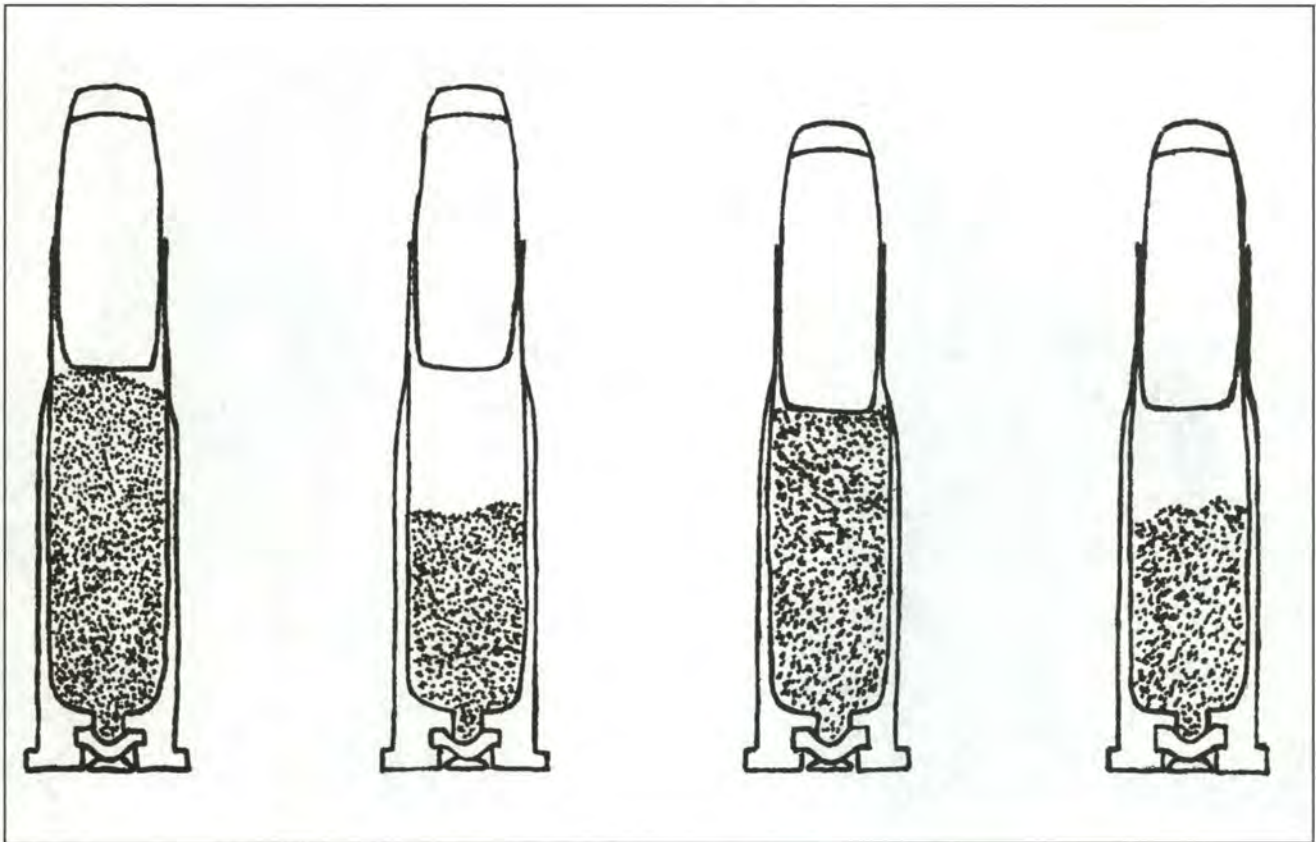

Loading density, the amount of powder and empty space in a cartridge, will affect the pressures therein, all other things being equal. The greater the density of the powder and the less space there is, the higher the pressure will be. On the left is a maximum, high-density load; next is a low-density load with the bullet seated far out. The pressure generated here would not be particularly high. Round number three contains the same load as number one, but it has been compressed by a deep-seated bullet. This would likely generate dangerously higher pressures. Round number four contains the same charge as number two, but will generate higher pressures. Case-wall thickness affects loading density by increasing or decreasing the internal capacity, a very critical point when a maximum load is used.

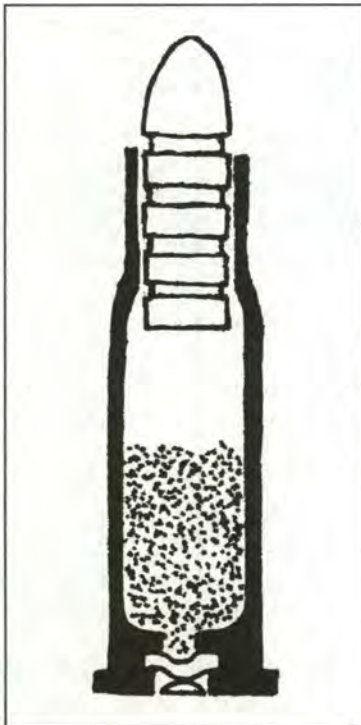

Never seat a cast bullet below the bottom of the neck into the shoulder area of a bottleneck case. The base will be melted and expanded, ruining accuracy and raising pressure.

and hotter, throw more sparks into the powder charge burning it more completely and more efficiently. This will generate more gas and, naturally, more pressure. It's best to stay with the primer types recommended by the loading manuals because pressure is affected.

#### Vent Hole Size

The vent hole is at the bottom of the primer pocket. Its size will affect powder burning rate by letting more of the primer flash pass into the case more quickly. A large vent, by increasing the rapidity of the burn, will raise pressures. Don't alter the size of the hole.

#### Case Capacity

All other things being equal, if the same amount of the same type of powder is loaded into a small capacity case such as a 223 Remington and a large capacity one such as a 45-70, much higher pressures will be generated in the smaller case. This is because there is less volume in the smaller case, thus less surface area for the pressure to work against. According to published data in the *Accurate Smokeless Powder Loading Guide Number One*, a load for the 223 of 23.5 grains of Accurate Arms 2495 BR powder behind an 80-grain jacketed bullet, generates an average of 51,600 psi



(Above and right) Slugging the bore consists of carefully driving a small, soft pure lead slug down the barrel. If done from both ends, the two slugs can be compared for tight and loose spots in the barrel.



The slug is measured from one land on one side to the land on the opposite side to find the groove diameter of the barrel.

of chamber pressure, while 66.0 grains of the same powder with a 300-grain jacketed bullet in the 45-70 generates about 22,100 psi. As mentioned in the previous chapter, some cases have slightly thicker walls and larger vents than others. Military cases are generally thicker than those made for the civilian market. This slight reduction in internal capacity can raise pressures.

### Overall Cartridge Length

By making a finished cartridge longer than it should be, the bullet may rest against or even be forced part way into the rifling. This will raise pressures. If a case is not trimmed to the proper length and the case mouth extends into the rifling, the mouth cannot expand properly and the bullet will be forced through what amounts to an undersize mouth in a swaging action that will jump pressures while degrading accuracy.

### Chamber and Bore Size

All American-made guns are standardized according to specifications set forth by the Sporting Arms and Ammunition Manufacturers Institute (SAMMI). Customized, foreign, and obsolete arms, however, may have dimensions different from this standard. Smaller, tight chambers and

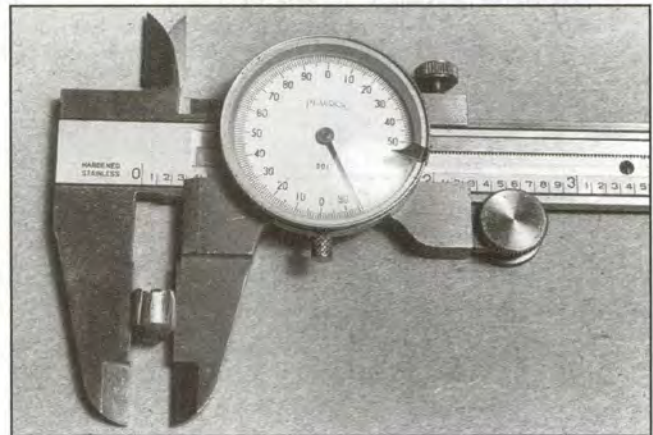

undersize bores can jump pressures with normal ammunition. When there is a reason for doubt about the size, slug the bore with a piece of soft lead to find the dimension. It's also pretty easy to make a chamber cast with Cerrosafe or sulfur to find the exact dimensions.

### Bullets

Bullets affect pressure, with the weight of the bullet having the most influence. The heavier they are the greater the pressure needed to get them moving. Beyond this is the hardness of the bullet.

Hard bronze or copper jacketed bullets require more energy to swage them into the rifling than does a soft lead

This is a drawing of a simplified crusher-type pressure gun used for measuring pressure. Pure copper and lead slugs are compressed to determine peak pressures on firing.

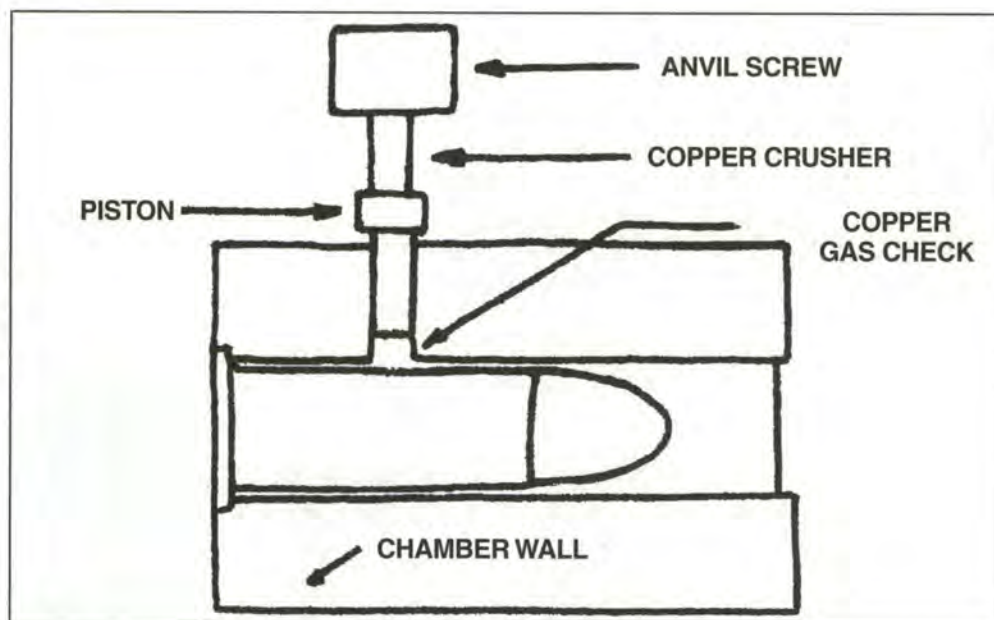

bullet, which is more easily engraved. Finally, there is the fit of the bullet in the bore. A tight fit offers more resistance than a loose fit where gas may blow by an undersize bullet that will not obturate the bore properly. A bullet seated too deeply—below the shoulder of a bottlenecked case—particularly a lead-alloy bullet, will often expand in the case and be swaged down as it passes into the neck. This will raise pressures and degrade accuracy.

### Instrumental Measurement of Pressure

Until the middle of the 19th century, the only way to test for maximum pressures was to keep increasing powder charges until the test gun blew up. It was thus assumed, at times erroneously, that similar guns would blow up with the same charge. Artillery designer Thomas Rodman developed one of the first pressure testing devices used in the U.S., in 1861. It consisted of boring a hole in a gun chamber and inserting a rod with a chisel point on the other end. A copper plate was affixed to the barrel above the chisel blade. After the gun was fired, the plate was compared to similar plates marked with chisel indentations made by known amounts of force. A year earlier, in England, Sir Andrew Noble developed a more refined device featuring a piston that fit tightly in a hole drilled in a chamber wall. A frame secured to the barrel held an anvil above the opposite end of the piston. Between the piston and the anvil, a small copper cylinder was placed. When the gun was fired, the cylinder was compressed and later compared to similar cylinders compressed by known degrees of force. The accuracy of this system depends on keeping the purity and hardness of the copper cylinders, called crushers, consistent. Calculations are affected by whether the cartridge case is first drilled, or the force needed to blow a hole in the case is factored in. Sharp pressure rises are more easily registered than more gradual ones. For shotgun ammunition, some handgun ammunition and rimfire ammunition that generate relatively low pressures, a lead cylinder is used instead of copper.

Measurements taken in this manner are expressed as copper units of pressure (CUP) or lead units of pressure (LUP). For the handloader, these can be interpreted as pounds per square inch (psi), the LUP, CUP designation simply indicating the means by which the measurement was taken.

More sophisticated systems of pressure measurement developed in this century consist of electronic transducer systems. These are of two types—piezoelectric and strain gage (yes, that's how it's spelled). The piezoelectric system, perfected in the mid-1930s, uses a quartz crystal in place of the copper cylinder, which is in a sealed tube with a diaphragm in the interior of the chamber wall. When subjected to pressure, the crystal generates electrical current in direct proportion to the amount of pressure applied. The advantage of such a system is a quick and relatively easy electronic readout and the reusability of the crystal. Disadvantages are calibration of equipment and crystals changing their value or varying in value.

The strain gage system derives pressure readings from implied information rather than direct. The device consists of a thin wire placed on the exterior surface of the chamber or around it. When the gun is fired, the chamber swells to a degree before returning to its original size, thus stretching the wire. The increased resistance in electrical conductivity of the stretched (thinner) wire during the firing sequence indicates pressure through the amount of stretch. Calibration is determined by measurement of inside and outside chamber diameters. Of the three systems, this one is of most interest to handloaders, since it is the only one that is non-destructive, in terms of not having to bore a hole in a gun chamber, and is available for home use. Such a device is the Personal Ballistics Laboratory Model 43 available from Oehler Research.

### Visible Signs of Pressure

For most handloaders these are the most critical indicators of something being wrong. They are also by far the

most unreliable and imprecise. There is no way to estimate pressure from observation or even physical measurement of cartridge cases or primers. Nevertheless, these components can warn of pressures that are in the danger zone.

As indicated in the previous chapter, case failures may have a number of causes, and sorting out the problem is often difficult. The only sensible way to determine whether your reloads may be too hot is to eliminate as many variables as possible, thus leaving only those cartridge anomalies

caused by excessive pressure or excessive headspace. These two problems produce similar appearing but different effects. What makes them difficult to differentiate is that any problems of excessive headspace are exacerbated by high pressure! Hard case extraction is a definite sign of high pressure unless you are dealing with an oversize or very rough chamber, which is generally something you can determine by looking into it. If your handload is more difficult to extract than a factory load of the same make, this tells

These three 44 Magnum cartridges were fired under the same conditions with the pressure measured by a copper crusher. Left to right: 31,800 CUP, 39,000 CUP, and 47,700 CUP. As can be seen, there is no discernible difference! (Photo courtesy Speer.)



The cratered primer (center) appears at first glance to be evidence of excessive pressure. The actual cause was an oversize firing pin hole and a soft primer.



Was the flat primer on the left a result of high pressure or being too soft? The answer is likely high pressure since the case head also flowed into the extractor groove (circled).

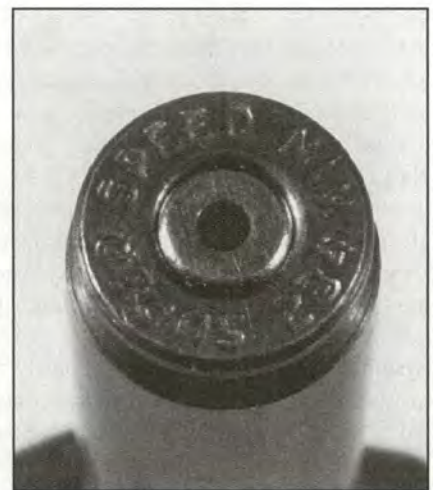

A pierced or "blown" primer can be caused by excessive pressure or a firing pin that is too long or too sharp. (Photo courtesy Speer.)

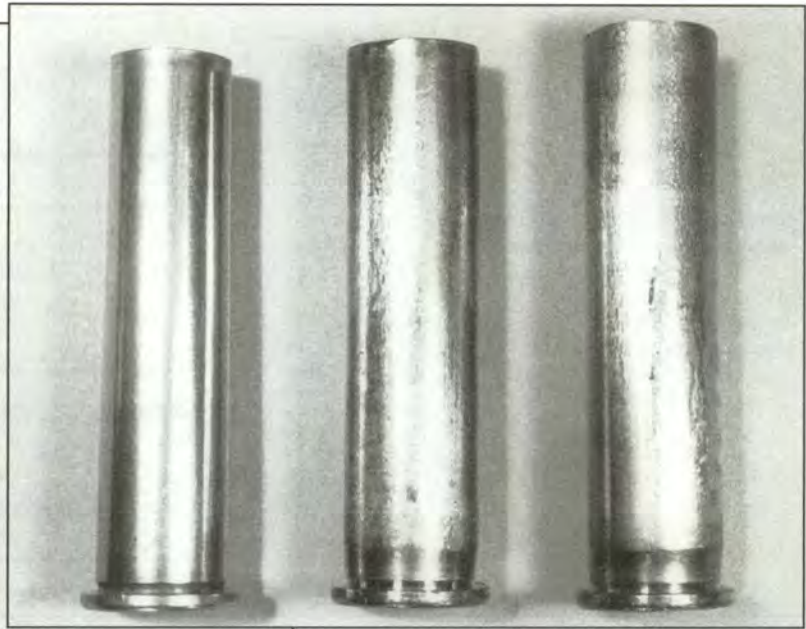
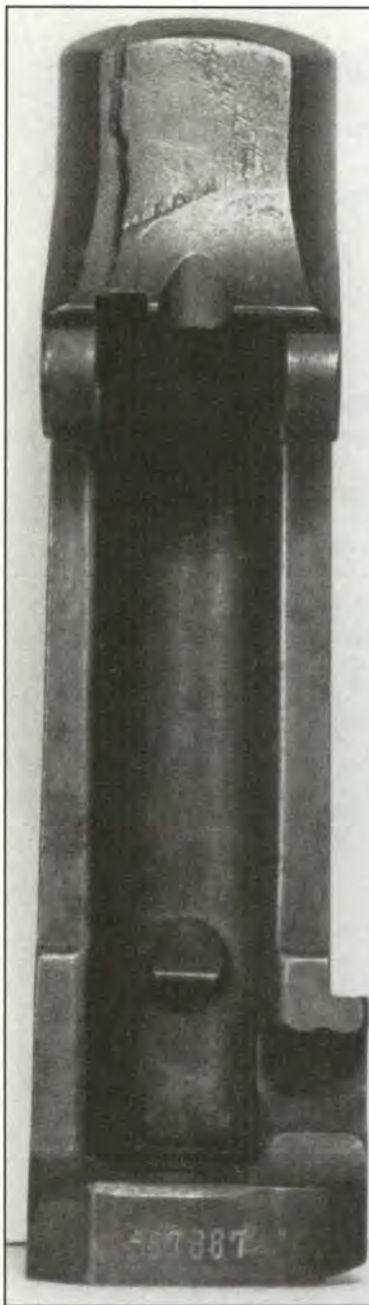

*Above) Definite signs of high pressure are obvious on these 45-70 cases. On the left is an unfired case. The center case was fired with a charge of 68 grains of IMR SR4759 powder—a 174 percent overload of the maximum loading (39 grains) for this powder with a 405-grain bullet. The barrel was bulged by this event, and the case had to be driven out with a rod. The case on the right was fired with 40 grains of Unique behind a 500-grain cast bullet. The maximum load for this bullet is 14.8 grains. This represents more than a 270 percent overload. The barrel of the gun was bulged to the point the receiver cracked. The case required considerable pounding with a hammer and a metal rod to remove it. Note the expansion in front of the solid head and stretching of the case.*

*A case-head separation is the worst event, with high pressure gas blowing back into the action and often into the face of the shooter. This is why you always wear shooting glasses. The old balloon-head case on the left, combined with a double charge, cracked the rifle receiver. The case on the right suffered a nearly complete separation because of mercuric priming.*

you that you have exceeded the elastic limit of the case and you are generating significantly higher pressures. A second way to check this is to take a micrometer measurement of the case-body diameter of a factory-loaded case after firing, and a handload using the same make of case after firing it for the first time. A larger diameter will indicate higher pressure than the factory load.

The flattening of primers is a sign of high pressure. However, many high-pressure rifle cartridges will show a good deal of flattening as a matter of course. Again, the critical factor is the difference between the flattening of a factory load and a handload using the same components fired for the first time. If the flattening is greater, you are getting higher pressure than the factory round and are in the upper limit of the margin of safety for your particular gun. Most

factory loads are near the maximum. This information is based on the "all other things being equal" premise. Whenever you suspect something is wrong, make sure all other things are equal and you are not introducing some factor that will alter your results. Getting oil or other lubricants on cartridge cases is part of the reloading process. This should be removed before firing. Oil in a chamber or on a case will cause the case to slide in the chamber instead of expanding and sticking to the chamber wall during firing. This causes excessive back thrust of the case against the bolt. Back thrust batters the case head, often transferring impressions of machining on the bolt face to the case head. These appear, to the untrained eye, to be caused by high pressure. Battering the bolt face will also—sooner than later—increase the headspace in the gun, which is a serious problem.

Headspace is measured between the face of the bolt and the front edge of the rim where it touches the breech on any rimmed case (top). Headspace on a rimless case is measured between the bolt face and the point where the case shoulder or the case mouth contacts the chamber.

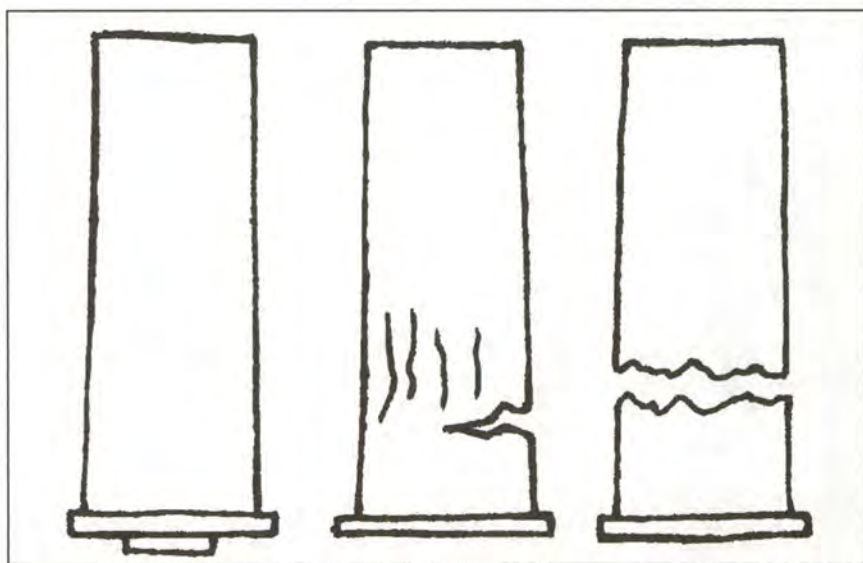
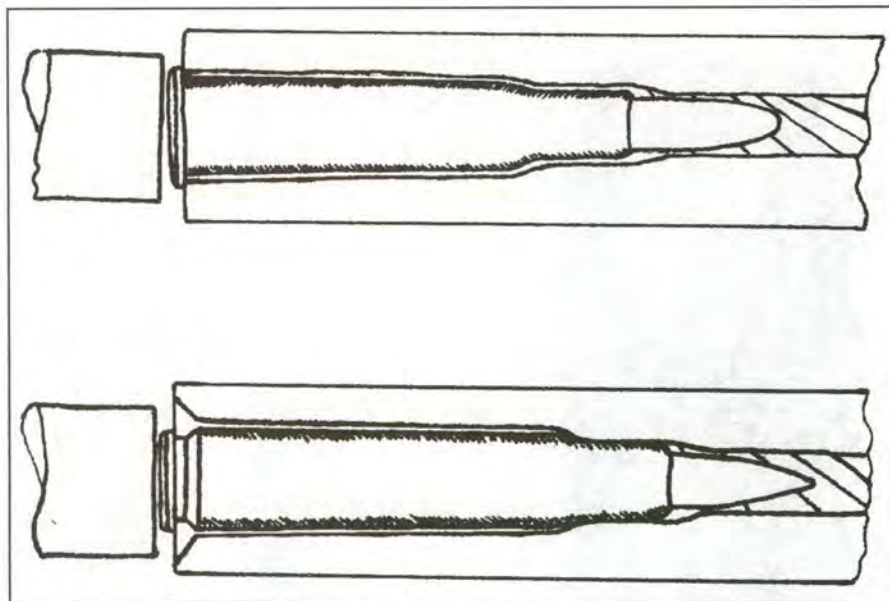

Excessive headspace signs begin as a backed-out primer. Stage two is the appearance of stretching and cracks. Stage three is separation. If excessive headspace is combined with an overload, stage three may be reached on the first loading.



Stretch marks and the crack on this case are indicative of excessive headspace. (Photo courtesy Speer.)

The puncturing of primers—a so-called “blown primer” where a hole is blown through the primer where the firing pin hits it—is a definite sign of very high pressure, unless you have a firing pin that is too long. Firing pins do not suddenly grow longer. Stop shooting! Before a primer blows, under pressure, there will be evidence of primers “cratering.” This is where the metal in the primer flows back around the tip of the firing pin and into the hole where the pin comes through the bolt or breechblock. Cratering can also be caused by a soft primer and an oversize firing pin hole. Here again, a comparison with a fired factory round with the same components is the best way to judge differences.

Gas leaks around primers make a black soot smudge at their edges, and may be a sign of high pressure or an enlarged primer pocket. Primer pocket stretching in a case will occur after a number of loadings, particularly high pressure ones. This tells you the case is finished for reload-

ing. If a leak occurs after long use, this can be assumed to be normal. When such a leak happens the first time with a new case, look for other high-pressure signs. Hard extraction, flattened or cratered primers, blown or leaky primers most often occur together.

Soot-streaking of cases when they are fired, particularly staining near the case mouth, is a sign not of high pressure, but of its opposite: low pressure. If a loading is not generating enough pressure to make a complete gas seal between the cartridge case and the chamber wall, a certain amount of gas will leak back into the chamber and smudge the case. Other than being a minor nuisance this causes no danger. It is an indication that combustion is at too low a level, owing to not enough powder or poor ignition of the powder. Such underpowered loads will tend to be inaccurate since the amount of gas that escapes will vary from shot to shot, depending on the elasticity of the individual case.



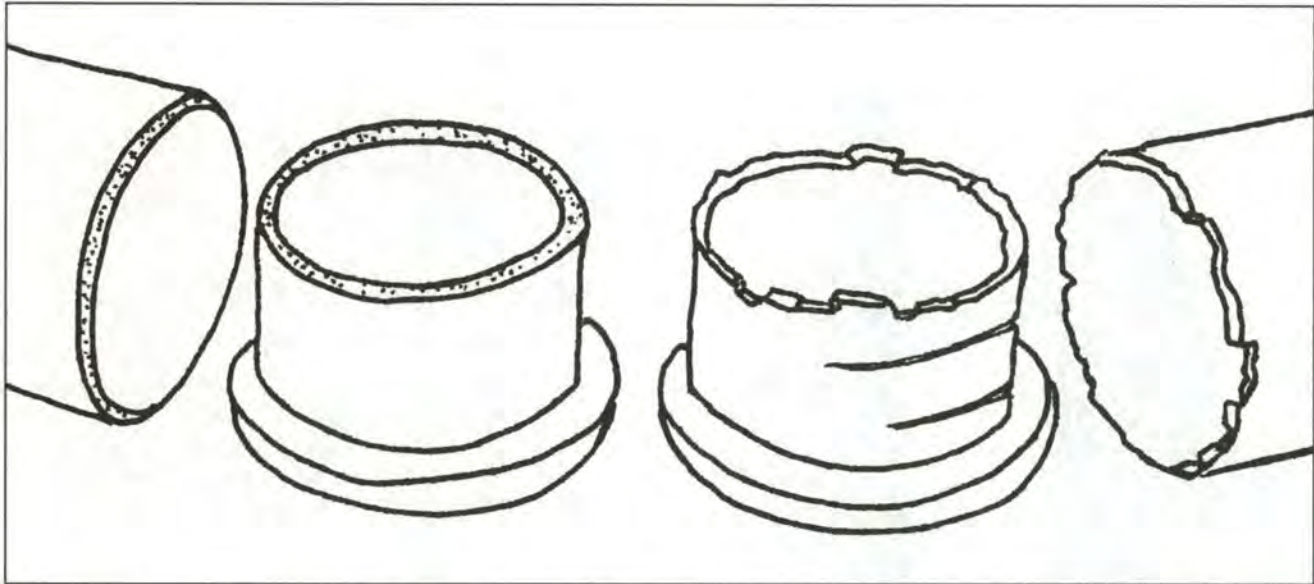

A case head separation has two basic causes. Type one is brass failure, often caused by mercuric priming contamination of brass that is otherwise weak and brittle. Type two is excessive headspace in the gun. These result in different types of fractures. Type one (left) is a clean break with a crystalline surface. Type two is characterized by tearing of the metal and stretch marks on the case.

## Understanding Headspace

In order for a cartridge to enter and exit a gun chamber it has to be made a little smaller than the chamber, with enough room for easy extraction after it is fired. To work properly, however, the case must be firmly supported by the bolt or breechblock to keep it from rupturing under pressure. The amount of tolerance between the head of the case and the face of the bolt or breechblock is less than 0.005-inch in a good modern gun. Zero tolerance would be best, but guns and ammunition are mass-produced products and a certain amount of tolerance must be permitted for variations that are part of the manufacturing process. A tolerance of several thousandths of an inch represents the elastic limits of the cartridge case, allowing the fired case to return to close to its original size for extraction. If the tolerance is greater, the elastic limits of the case are exceeded and it will begin to deform or even rupture. This situation is known as excessive headspace.

Tolerances for headspace are set at the factory and remain in place for the life of a gun. That life is shortened by shooting high-pressure loads which batter the bolt or breechblock, gradually increasing the headspace. This problem can be corrected by a skilled gunsmith, depending on the type of gun and how bad the situation has become.

### Calculating Headspace

Headspace is measured with gauges to .001-inch. In a rimmed or semi-rimmed case, the headspace measurement is between the surface of the bolt or breechblock and the point where the front of the cartridge rim makes contact with the face of the breech. With rimless cases, the measurement is between the bolt face and the point where the shoulder of the case makes contact with the counterbore in the chamber. For straight rimless cases such as the 45 ACP, the

measurement is to the point where the case mouth makes contact with the front of the chamber.

### Excessive Headspace

This is when the tolerances are too great. When this situation occurs, the cartridge case is held tightly forward against the chamber walls upon firing. With the case head unsupported by the bolt or breechblock, the case stretches backward under the force of the pressure inside it, until it makes contact with the bolt face and stops. Usually before this happens, the primer is pushed out of its pocket until it meets the bolt face. As pressure drops in the chamber, the case springs back and creeps back over the primer, often jamming the now-expanded primer back into the pocket. On examination, the flattened primer will appear for all the world like an example of high pressure. The reloader should make sure he has not loaded a maximum load. If this was a max load, he should try a factory cartridge for comparison. If the problem is excessive headspace the signs should be there with normal loads, and they may appear even with reduced loads although somewhat less obvious. Often, the only sign will be a primer backed out of the case.

After a case is stretched in an overly long chamber, is resized, reloaded and fired, the stretching process is repeated with the next firing. Stretch marks, in the form of shiny rings, begin to appear around the circumference of the case body forward of the head. After a number of reloadings, depending on how much stretching and resizing occurs, the case will become fatigued and rupture, blowing high-pressure gas back into the action. This often destroys the gun, and injures the face of the shooter. A combination of poor brass, a heavy load and a lot of extra headspace can bring on this condition in a single shot. Headspace problems can be created in the reloading process.

This occurs with rimless cases such as the 30-06 and 223

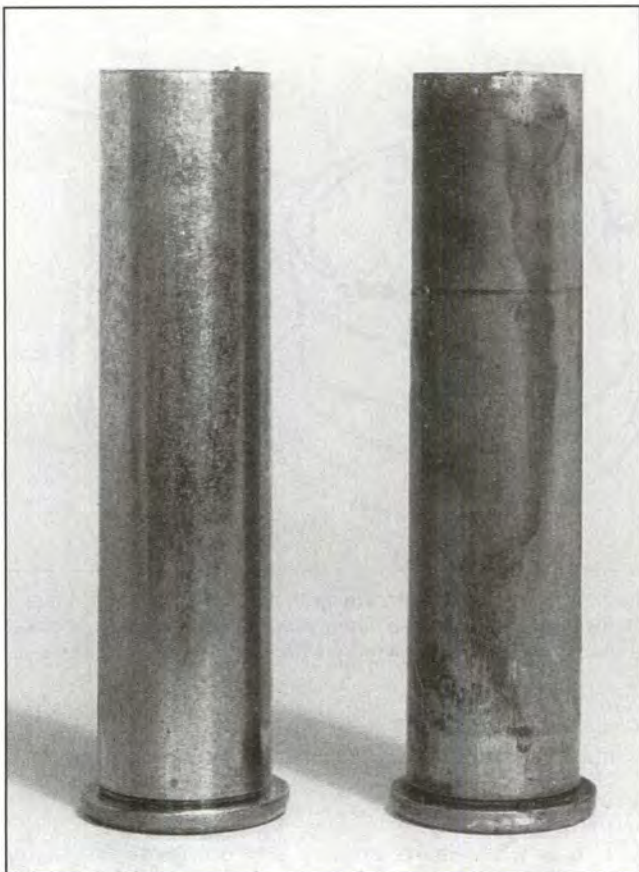

Low pressure is evidenced by the soot stains on the case on the right, which failed to make a complete gas seal when fired.



Primer pockets will stretch, as did the one on the left after a number of heavy loads. If the leak or stretch appears suddenly on a new or nearly new case, you are in the very high pressure range and should reduce your loads.



A leak around a primer indicates an expanded primer pocket. Time to discard the case.

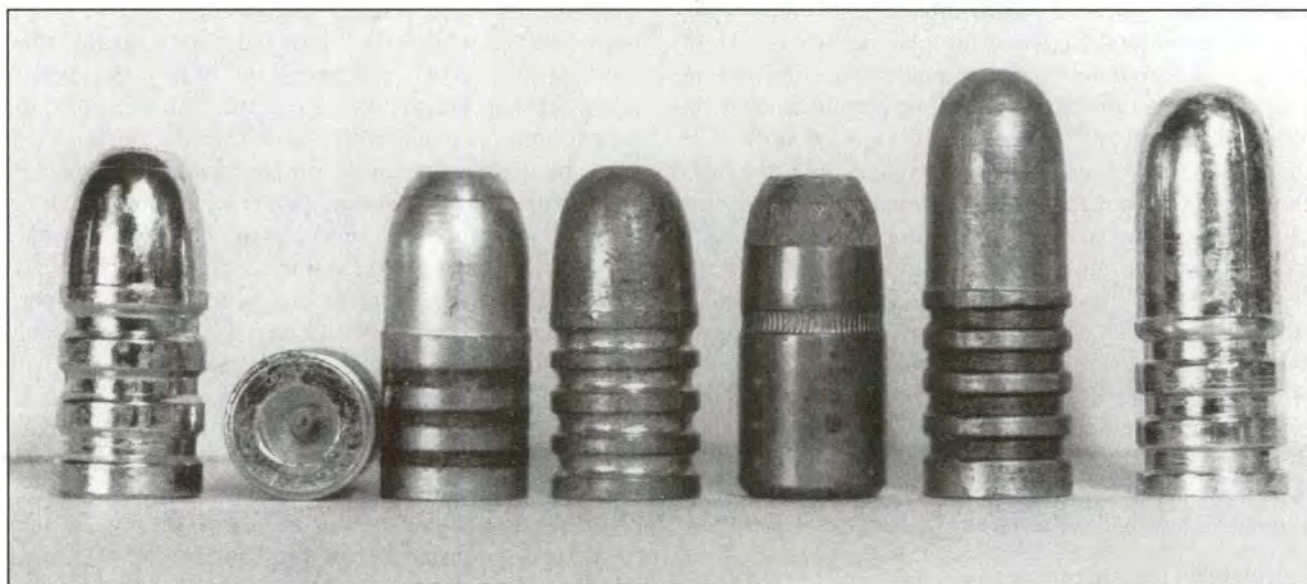

Soft alloy bullets of lead and tin (the shiny ones on the ends) will yield lower pressures than harder alloy bullets. Jacketed bullets (third from right) create significantly higher pressures, as do heavier bullets.

where improper use of the sizing die forces the shoulder back on the case body, allowing the case to go further into the chamber than it should. The extractor hook will hold the case in the proper position for firing, but the case has now become too short and has to stretch back to meet the

bolt face. If this practice is continued, it is only a matter of time until a rupture occurs with all the grief that goes with it. Any gun showing signs of excessive headspace should not be fired. Examination by a skilled gunsmith will tell you if the situation can be corrected.

Over the years, ignition of the powder charge has been accomplished in a number of ways. Today, big things come from small packages.

# Primers

**THE PURPOSE OF** the primer is to ignite the main powder charge. This was originally done with a burning splinter or hot wire jammed into a small touchhole at the breech of the gun. Later, a smoldering rope or sparks from iron pyrites and flint striking steel were employed to set off a small charge of powder in a funnel that connected with the main charge in the gun barrel. These systems worked, but they didn't work well, which prompted a search for an ignition system that fulfilled the four criteria of today's modern primers, namely: speed, reliability, uniformity and cleanliness.

## Primer Evolution

Early ignition systems failed in all the above criteria. Matchlocks were equipped with a smoldering fuse made of chemically treated rope, called a "match," which would burn out in damp weather and could be blown out by wind. With flintlocks, wind could blow the priming charge out of the pan, and wet, damp weather would saturate it with moisture to the

Modern percussion caps are essentially a primer without an anvil inside it, that part being provided by the nipple on the gun.

(Below) Berdan (left) and Boxer primer pockets show the differences in the systems. The ease of reloading made the Boxer primer standard in the U.S. (Photo courtesy Speer.)



point where it would not fire. Rust and powder fouling in the touchhole that connected the pan charge to the propelling charge in the barrel often prevented a successful firing, with only the priming charge burning. The expression, “a flash in the pan,” is still used to describe a person or enterprise that shows promise, but fails to get past a good beginning. The flintlock system gave only reasonable reliability. A small piece of flint held in the jaws of the “hammer” (called the cock) struck a steel cover on the pan called the frizzen, knocking it open and scraping the inner side to throw sparks into the powder charge in the pan. In terms of speed it was slow. Anyone who has seen a flintlock fired is familiar with the *puff-boom!* report as the priming charge burns with a one-beat pause before the propelling charge fires. History is filled with untold numbers of targets, animal and human, who have ducked to safety during that beat—which was sometimes two beats if the day was damp and the touchhole a bit clogged.

Explosives such as fulminate of mercury and mixtures including potassium chlorate, that detonated when crushed or struck, were discovered late in the 18th century. After attempts to use them as substitutes for gunpowder failed, they received little attention until the early 19th century.

The breakthrough to improved ignition was made by a Scottish Presbyterian minister, hunter, shooter and gun buff—Reverend Alexander Forsythe. He was the first to come up with the idea of using these detonating explosives to ignite propelling charges in firearms. He received a patent in 1807 for a system that did away with the priming pan on the flintlock. This design filled the tube leading to the

barrel with a percussion explosive made of sulphur, potassium chlorate and charcoal. A metal pin was inserted on top of the explosive that caused it to detonate when struck by the gun’s hammer. The ignition was far faster and more certain than the flintlock. Forsythe improved his design by attaching a small iron bottle containing a supply of percussion explosive to the side of the lock. The bottle could be tipped or turned to deposit a small pellet of explosive on a touchhole, which would be struck by the hammer. The system worked effectively. However, it involved having a small iron bottle filled with high explosive very close to the firing point and to the face of the shooter. There are no reports of accidents with a Forsythe lock, but if one happened, it would almost certainly have been fatal.

The superiority of the Forsythe system was soon recognized and dozens of variations were introduced, including percussion wafers, tubes and strips of paper caps, much like those used in toy cap pistols of today. The most successful was the percussion cap, invented in about 1814 by Joshua Shaw, a British subject who immigrated to America. Shaw’s system featured a small steel tube, closed at one end, about the size of a modern large pistol primer. The closed end contained the explosive held in place by a tinfoil cover, then sealed with a drop of lacquer. This made it waterproof as well as damp-proof. The cap was fitted on a short iron nipple, hollow in the center, which allowed the fire to enter the chamber of the gun. Shaw caps were on the market by 1821 and were soon adapted to sporting guns. Improvements were made by changing the cap metal to pewter and later copper. Similar caps were in use about the same time over most of Europe. The percussion cap was not adopted by the U.S. military until after the Mexican War. The military thinking at the time was that the percussion cap was yet another component the soldier had to carry and not reusable in the manner of a gun flint.

Percussion caps made the Colt revolver a practical reality, but the shortcomings of this system became apparent when repeating rifles were made using this system. A cylinder “flash over” from one chamber to the next would occasionally send a bullet coasting by the side of the gun.

Early tong reloading tools could be carried in the pocket or saddlebag. These in 32-20 (top) and 38-40 WCF from the old Ideal Company cast bullets, decapped, primed and seated bullets in blackpowder calibers.

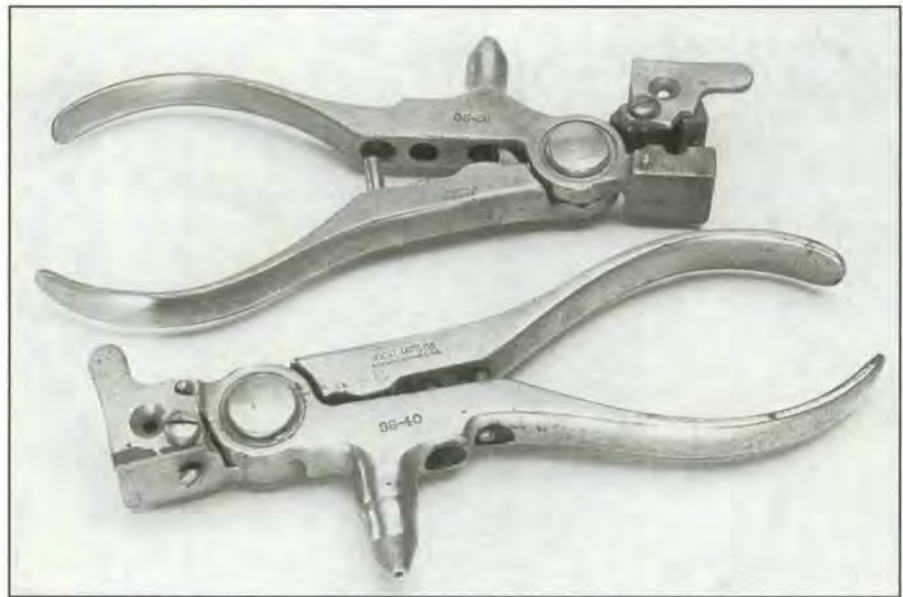

(Below) The Lee Hand Press Kit is a modern version of the old Ideal tong tool. The kit includes dies, case lube, powder dipper, etc.



With a handgun this was of little consequence since it was a one-hand weapon. With the revolving rifle such an event often amputated the fingers or thumb of the hand supporting the forend of the weapon. Revolving rifles did not gain much popularity.

Not surprisingly, the first really successful breechloaders and successful repeating arms, other than revolvers, required a self-contained, self-primed cartridge. There were a number of important steps between the percussion cap and the rimfire cartridge, but to list them here is not our mission. Suffice it to say there was a fairly logical evolution. In brief, George Morse placed a percussion cap in the head of a metal cartridge using a hairpin-shaped anvil inside the case to fire it. Hiram Berdan shortened the hairpin to a tiny knob, while Edward Boxer placed a tiny anvil inside the cap.

### Center Primed

Centerfire ammunition soon eclipsed the rimfire and all the other non-reloadable types because it was reloadable. Rimfires were gradually reduced to those types that were so small that the cartridge would not lend itself to reloading. The military had great influence in ammunition development, stipulating that any ammunition developed for a

military small arm had to be reloadable. Spent cases were collected and returned to a government arsenal for reloading during peacetime. Professional hunters in the American West needed cartridges they could reload themselves with simple tools. It was this type of equipment that first appeared in the 1870s.

Early priming mixtures used fulminate of mercury or potassium chlorate, occasionally a combination of both. These fulfilled most of the criteria for good ignition: speed, reliability, uniformity, and cleanliness to some extent. While the chlorate-based primers and caps did not leave an appreciable residue, they did leave a highly corrosive deposit—potassium chloride—that would eat away a percussion nipple or the web of a cartridge. This needed to be neutralized by cleaning the gun with water that removed the salt deposit. The mercury-based compounds were both clean and non-corrosive. Their drawback came when used in combination with brass or copper primer cups and cartridge cases. When fired, the mercury would amalgamate with the copper or brass making it extremely brittle. Reloading and firing such a contaminated cartridge case can lead to a case-head rupture. In a high-pressure loading, this can wreck a gun and possibly your face. Mercuric priming was gone from commercial ammunition by about 1945, but primers made prior to this time were used by commercial reloaders for a number of years later.

Because fulminate of mercury contains free, liquid mercury, this mercury will actually migrate through the priming mixture and into the metal of the primer cup or cartridge head after a certain number of years. Ammunition primed with mercuric mixtures made in the early 1930s will probably not fire today. However, ammunition loaded with chlorate priming made during the Civil War is often still viable, so long as neither the powder nor the priming compound has been exposed to moisture. Thus, a fifth criterion should be added—long life.

From the late '20s through the mid-1930s, American



Pistol and rifle primers come in two sizes, while shotshell primers are of one size.

(Below) Pistol primers should not be used in rifle cases since they will seat too deeply, as in the case on the left. The center case shows proper seating depth, while the high primer on the right will give poor ignition and possibly slam-fire in an autoloader.

manufacturers worked to perfect a priming mixture, akin to one developed in Germany, which was noncorrosive and did not contain mercury. The basis of such priming is in compounds of lead, barium and antimony.

Early noncorrosive, non-mercuric primers did not work very well, giving uneven ignition. Priming material often fell out of the rim in rimfire cartridges as the binding material—a vegetable-based glue—deteriorated.

### The Modern Primer

Modern primers of the lead, barium and antimony type fulfill all the necessary criteria for good ignition. The binders are now stable and remain so for long periods under normal “house” storage conditions, where temperatures are under 125 degrees Fahrenheit and moisture is kept at a reasonable level. The newest are the “lead free” primers of tetracene. These, however, are not presently sold as reloading components since the production demand is for use in finished ammunition. The primary use of such primers is in handgun ammunition to be fired in indoor ranges where airborne lead could present a health hazard.

Because of the difficulty of reloading them, cartridges using Berdan primers and the Berdan primers themselves have virtually disappeared from the U.S. Foreign cartridges often still use this type of priming and can only be reloaded with Berdan primers. Any attempt to convert Berdan cases to Boxer priming by drilling them in some manner will not work. Such attempts are very dangerous since they will greatly enlarge the flashhole and may damage the web. At best, such conversions give uneven ignition, at worst they can raise pressures to dangerous levels by causing too rapid a burn of the powder charge. The only current source for Berdan primers and Berdan decapping equipment is The Old Western Scrounger.

A modern Boxer primer differs little in structure from those made over a century ago. It is a brass cup containing the priming compound. A paper seal keeps the compound



in the cup and is held in place by the metal anvil made of harder brass. A better understanding of metallurgy and chemistry has resulted in a more uniform primer as well as ones that are specifically tailored to a particular type of cartridge.

Primers for pistols and rifles come in two basic sizes of small (.175-inch) and large (.210-inch). There also is a .317-inch primer made by CCI and used only in the 50 Browning machinegun cartridge. Small pistol primers are used in such rounds as 25- and 32-caliber handgun ammunition, while the large size is used in 41-, 44- and 45-caliber handguns. Large pistol primers are also made in a magnum variant, for use in large capacity cases using hard-to-ignite, slow-burning powders. These require a longer, hotter flame for uniform and complete burning.

Rifle primers are made in the same two diameters as pistol primers, and are designated small and large. They are slightly higher to fit the deeper pocket in the rifle cartridge case. For this reason, pistol primers should not be seated in rifle cases since they will seat too deeply and often give uneven ignition. Rifle primers contain more priming compound than pistol primers since they have to ignite more powder in larger capacity cases.

If you are loading both handgun and rifle ammunition, care must be taken not to mix rifle and handgun primers. If rifle primers are seated in pistol cases they will not fit

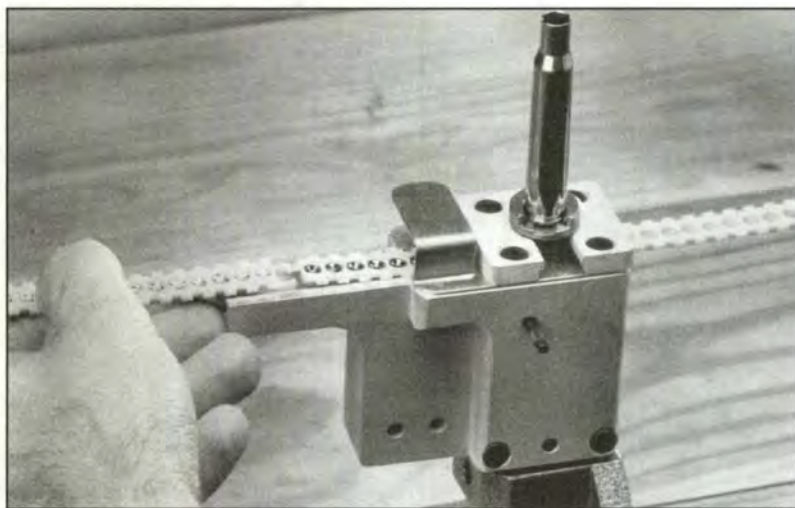

The RCBS APS primer feeder uses plastic strips instead of the conventional stacking tube, reducing the hazard of sympathetic detonation. (Photo courtesy RCBS.)



properly. They can also raise pressures to the danger point. Pistol primers tend to burn cooler, and produce more of a flame-type of explosion—good for igniting fast-burning pistol powders. Rifle primers burn longer and hotter. They often contain metallic elements such as aluminum, which act as burning sparks that are blown forward into a charge of slower-burning powder. This separates the grains, igniting them in a number of places at once, to achieve an even burning of the charge. This explosive quality is known as brisance. Magnum rifle primers have still more compound, burn longer and hotter and are used in very large-capacity cases such as the 458 Winchester Magnum. Companies such as CCI also market a benchrest rifle primer. This is



(Left and above) Primers are sold preloaded in strips, but the strips can be refilled with the RCBS loading tool. You have to buy the system. (Photos courtesy RCBS)

simply a standard rifle primer, but made to very strict tolerances, assuring the reloader that each primer in a given lot will have a very precisely measured amount of compound, and that the diameter and hardness of all components are within very strict tolerances. These premium-quality primers give very even ignition needed for the exacting demands of the expert competition target shooter.

Shotshell primers have special characteristics needed to work properly in modern plastic shotshells. Early shotshells were made of brass and were generally of rifle-type of construction. They used rifle-style primers. Modern shells are of a composite construction with a metal head surrounding a paper, now primarily a plastic body. Inside is a base wad made of plastic or compressed paper.

Shotshells have unique ignition problems. As the mouth of the shell becomes worn and softened with repeated firing and reloading, the opening of the crimp becomes progressively easier. Modern shotgun powders require a certain amount of pressure and confinement to function properly. This decreases as the crimp softens. For proper ignition, the

powder requires a very high temperature over a longer than usual burn time, but without the brisant quality of the magnum rifle powder which would tend to blow the crimp open before much of the powder was ignited. A shotshell primer produces what is often referred to as a "soft ignition."

Because of the design of modern shotshells, the primer is held in a large, longer-than-normal housing called a battery cup. This extends well into the base wad so the flame issuing from the primer mouth will not be inhibited by any part of the wad and can direct its full blast into the powder charge.

### Handling and Storage

Primers are the most dangerous component in the reloading operation. They are subject to shock and explode with a violence that belies their small size. Children often have a penchant for playing with small shiny objects and primers should definitely be kept out of their hands. Primers are packaged to keep them from shock and from striking one another. Julian Hatcher, in his *Notebook*, tells of a young worker in an ammunition plant carrying a metal bucket of primers, casually bouncing it as he walked. There was a sudden, violent explosion. A part of a foot was the largest piece recovered.

Primers should only be stored in the original packaging, never in a can or bottle where they can rattle around. Automatic primer feeding devices of a tube design should be loaded with great care, because this brings a considerable number together in way that if one accidentally explodes, the remainder will go too. The explosive force of a primer is many, many times that of the most powerful smokeless powder.

Properly stored, primers do not present a particularly dangerous hazard. They will pop quite loudly if thrown in a fire, and come flying with enough force to penetrate a cardboard carton a foot or more away. People have lost eyesight from such injuries, so this is not the way to dispose of damaged, though unexploded, primers. Perhaps the best method is to load them in an empty cartridge case and snap them. If this is not possible, they can be deactivated by soaking in a strong lye solution for a week. The liquid may be flushed away with a large quantity of water. The potassium chlorate in the old corrosive primers is very water-soluble and water soaking works well with this type. We are talking here about small numbers of primers, not more than two dozen. If for some reason you should have to dispose of a large number of primers, call your local gun shop to see if they can use them.

Shelf storage should be in a cool dry place, away from containers of gunpowder and away from children's reach. To avoid an explosion hazard in case of fire, primers should not be stored in a closed heavy metal container such as a military ammunition can.

The lacquer seals used in modern primers keeps them free of deterioration from dampness, but basement storage is not recommended for any ammunition component unless that basement is kept dry with a dehumidifier. About the



The shotshell battery cup primer comes with the primer pocket and vent as part of the unit, all of which is replaced when the shell is reprimed.

only uniquely vulnerable feature about primers is the paper seal, which could be attacked by molds under extremely damp conditions.

Three questions are frequently asked by shooters of military, foreign, and obsolete guns: (1) How can you determine if the military ammunition you are planning to shoot and reload is Berdan primed? (2) How can you determine which ammunition is corrosively primed? (3) How can you tell if a case has been contaminated by mercuric primers?

The answer to the first is fairly simple—usually. The Berdan primers are almost always of a larger diameter than the equivalent Boxer primers, although the CCI primer used in their non-reloadable Blazer ammunition is virtually the same size. Most foreign military primers are the Berdan type and are usually larger. The surest way to know is to examine a fired cartridge case and look into the case for the small twin vents that are the trademark of this system. This is not possible when buying ammunition. About the best you can do is ask the dealer if the stuff is Boxer-primed or not, and get a guarantee that if it isn't, he will take the unfired portion back.

Determining which ammunition has corrosive priming is a little more complicated. Corrosive priming was a serious problem in the early days of smokeless powder ammunition, since corrosive salts were deposited in large quantities in the barrels of guns that fired it. Blackpowder fouling, while corrosive to a degree, helped to hold these salts and the fouling was relatively easy to clean with a soap and warm water mixture. After cleaning, the bore was wiped dry and then oiled to protect it. With the introduction of smokeless powder, there was very little powder fouling in the bore. Jacketed bullets moving at high velocities left a hard metallic deposit composed of copper and nickel from the jackets. This was difficult to remove and trapped the corrosive salt (potassium chloride) in a layer between the barrel surface and the metal fouling. A barrel could appear perfectly clean but, days later, even though the bore was saturated with oil or grease, it would rust heavily under this protective coating.

To combat this problem, cleaning solvents were devel-





Crystal Cleaner was an ammonia-based metal solvent offered by Winchester in the early days of corrosive priming. The U.S. military bore cleaner in the old dark green can combined ammonia and powder solvent in a brown, evil-smelling liquid. It did/does a good job of removing corrosive primer residue and metal fouling.

oped that would dissolve this metal fouling and remove the salts from the corrosive priming. Most of these solvents contained ammonia, which readily dissolves copper and nickel. A water-based solution of ammonia does a very good job of removing both metal fouling and primer salts. Years ago, after firing a lot of corrosive ammunition, one shooter removed fouling by corking the chamber of a 303 Enfield with a rubber stopper and carefully filling the bore with household ammonia, then letting it stand for an hour or so. The dissolved salts and copper fouling were removed when the barrel was tipped. The fouling was obvious in the blue-green tint it gave to the ammonia solution. After dumping the liquid, a couple of wet patches were run through the bore, then a couple of dry patches, and the bore was swabbed with Hoppe's No. 9 solvent until everything came clean. Care had to be taken not to spill ammonia on any blued surface since it will remove the blue. He was also careful not to leave the solution too long, or worse let it dry, on any exposed steel surface since it will readily rust that surface.

Commercial solvents with ammonia, bearing names like "Chlor oil," "Fiend oil" and "Crystal Cleaner" were once marketed for cleaning up corrosive priming. They have been gone from the scene so long that few people remember their names. The U.S. military came up with its own preparation called, simply, "Bore Cleaner." This was a dark brown concoction with a smell you will never forget, (although

**CORROSIVE/NON-CORROSIVE PRIMING: U.S. MILITARY AMMUNITION**  
(U.S.- and Canadian-manufactured ammunition)

Headstamp	Mfr.	Changeover Date	Non-Corr. Headstamp
FA	Frankford	Oct 1951 (30) July 1954 (45)	FA 52- FA 55-
DEN	Denver	All corrosive during WWII	
DM	Des Moines	All corrosive during WWII	
EC	Eau Claire	All corrosive during WWII	
LC	Lake City	June 1951 (30) April 1952 (30 AP)	LC 52 LC 53
SL	St. Louis	May 1952 (30) July 1952 (30 AP)	SL 53 SL 53
TW	Twin Cities	Dec 1950 (30) Feb 1952 (30 AP)	TW 51 TW 53
U and UT	Utah	All corrosive during WWII	
DAQ	Dominion (Canada)	All noncorrosive	
VC	Verdun (Canada)	All noncorrosive	
FCC	Federal	Nov 1953 (45)	FC 54-
RA	Remington	Nov 1951 (30) Sept 1952 (45)	RA 52- RA 53-
WCC	Western	June 1951 (30) Nov 1952 (45)	WCC 52- WCC 53-
WRA	Winchester	Aug 1951 (30) June 1954 (30 AP) Nov 1951 (45)	WRA 52- WRA 53- WRA 52-



(Above and below) Military ammunition generally has the primer swaged in the case with a primer crimp, which makes first-time removal a little difficult. Once the crimp is removed, however, there is no further problem.



All 223 (5.56mm), 30 Carbine, 308 (7.62mm), 9mm Luger and 38 Special military ammunition is non-corrosive. Exceptions are the 1956 NATO 308 Match ammunition made at the Frankford Arsenal and 30-06 Match ammunition made at the Frankford Arsenal in 1953, 1954 and 1956. All are stamped FA with the two-digit date. (This information was adapted from the NRA *Handloader's Guide*.)

you wish you could) that combined ammonia with water-soluble oil and powder solvents. Bad as it smelled, it worked quite well.

Corrosive priming was gone from commercial ammunition by the 1930s. In the early 1950s, noncorrosive priming gradually replaced the corrosive type in U.S. military ammunition. A decade or so later, the Army switched to a newer type of bore cleaner which is sold commercially under the name "Break Free." By this time most shooters had forgotten about corrosive-primed ammunition. Today's cleaners do a fine job of removing powder fouling and preventing rust from external causes, but they do not remove corrosive potassium salt. This must be removed with a water-based cleaner since salt does not dissolve in oil.

With the importation of Russian and Chinese Tokarev, Moisin-Nagant, SKS and AKM rifles and ammunition, corrosive priming is back on the American scene. Most of the current powder solvents are ineffective in removing the corrosive salt. Probably the best way to deal with this is to get some of the old Army bore cleaner and clean with that. It is still available at many gun shops, gun shows and military-surplus outlets. Another option is to use one of the solvents that remove copper fouling. After cleaning with that, run several wet patches then dry patches until the bore is clean; then oil with a good protective oil or grease with rust inhibitors.

Identifying corrosive-primed American military ammunition is an easy matter of consulting the nearby list that was compiled by the NRA several years ago. When it comes to foreign ammunition, unless it is in the original box from a commercial manufacturer and clearly marked "Non-corrosive," assume it is corrosive, particularly if it is military ammunition, especially that from any former East Bloc country. If you wish to experiment, collect some fired cases and place them outdoors for a week or two in warm humid weather, or place them on their heads with a drop or two of water in each and let them stand over night. If corrosive salt

is present, there will usually be evidence of corrosion inside the case particularly near the vent, especially if that case is made of steel.

The question of mercuric priming is best dealt with on the basis of: If the ammunition or cases are pre-WWII and not corrosive-primed, they are likely mercuric-primed. If the ammunition is in the original box and the box declares it to be "noncorrosive, nonmercuric," and it's in good (appearing) condition, it's probably good to shoot. Keep in mind that if the old nonmercuric primers are no good, the bullets can be pulled and the cartridges can be reloaded, if you think it's worth the effort.

Oftentimes batches of old fired cases turn up and the shooter has no idea whether they are usable. If the caliber is something currently available, don't bother. The knotty problem is when such a batch turns up in some obsolete caliber, and you have one of those rifles and nothing to shoot in it. Converting some other cartridge to these is very difficult. Loaded new ammunition in these old calibers is sometimes available from companies like The Old Western Scrounger, but a considerable prices. Even at high prices, a batch of old cases might be a bargain, if they are in good condition and all the same make. If there is heavy tarnish and season cracking, forget it. If they have a scaly appearance or are stretched, bulged or otherwise show damage or distortion, forget it. This leaves the possibility of mercury contamination, which leaves no visible evidence. The only test to make the determination of mercury contamination comes from *Handloader's Manual* by Earl Naramore, published in 1937. Naramore states that you must sacrifice a case for testing. It must be carefully sectioned with a fine hacksaw. After sectioning, the cut surface it should be filed with a fine metal file to remove the saw marks, then polished on a piece of fine emery paper or crocus cloth. The polished case is then submerged for a few seconds in a 20 percent solution of nitric acid until the polished surface takes on a dull or slightly roughened appearance. Leaving the case in the bath too long will pit the surface.

After the case is properly etched, the walls can be examined with a magnifying glass for flaws in the metal. The case should be removed from the etching bath with a pair of tweezers and washed in clear water. States Naramore: "The action of the nitric acid will clean the fouling from the inside of the case thoroughly and if the surface has a silvery appearance, it is a sure indication that the case has been fired with a mercuric primer. This silver-looking coating, which is really mercury, will disappear into the brass after the specimen has stood a little while, so the condition should be looked for immediately after taking the case out of the etching solution. Unfortunately the failure of the mercury to appear does not offer assurance that the case has never been fired with a mercuric primer, but the mercury will usually show up." Naramore goes on to urge the reloader to examine the etched case for cracks or splits in the head, which can usually be seen with the unaided eye or with a magnifying glass.



Primer crimps are easily removed with this handy tool (and others), which also swages the primer pockets to uniform size.

Once you pop the primer, you need to fuel the fire, and propellants come in many types, shapes and sizes.

# Powders

**GUNPOWDER IS THE** driving force that makes a gun shoot. It does this by changing from a solid to a large volume of hot gas in a very short time in what is best termed a low-velocity explosion. This works very well for propelling bullets down gun barrels without raising the pressure too suddenly, which would cause the barrel to burst before the bullet gets moving. High velocity or “high” explosives are unsuitable for use in guns for this reason.

## **Blackpowder and Its Variants**

The original “gunpowder” is what is now referred to as “Blackpowder,” and is actually a dark gray in color. Its origin dates back about a thousand years. All sorts of ingredients have been added at various times, but the basic mixture is composed of potassium nitrate (75 percent), charcoal (15 percent), and sulphur (10 percent). Many people have made blackpowder at home. This practice is not recommended simply because it is dangerous. One mistake can prove disastrous. Such a mistake cost one shooter both hands at the age of fifteen. And he considered himself lucky to still have



American manufacturers and importers offer a wide variety of smokeless powder for reloaders.

everything else intact. For those not impressed by danger, it may be added that homemade powder is never up to the standards of purity and consistency of the manufactured product. The burning rate of blackpowder is determined by the size of the granulation. Very fine powder burns very rapidly and can raise pressures into the danger zone if the improper granulation is used in an otherwise safe load. Some people say you cannot overload a gun with blackpowder. Not true.

Commercial blackpowder is mixed, then ground in a wet state to prevent an explosion. It is pressed into a cake, then granulated and sifted through screens to determine grain size. The grains are coated with graphite for ease in pouring. It is sold in four granulations: FFFFg for priming flintlocks; FFFg for handguns and rifles to 40-caliber; FFg for rifles above 40- to 58-caliber; and Fg for rifles over 58-caliber and large bore shotguns.

Blackpowder has many deficiencies. It produces a great deal of smoke and solid fouling when burned. Better than half the residue is in solid form. While most of this is blown out of the barrel, a heavy, often hard-crusting fouling is produced which will soon degrade accuracy and raise pressures unless the bore is cleaned. Blackpowder target shooters often swab their barrels after every shot to maintain top accuracy. The fouling from blackpowder is corrosive, mainly because it contains sulfuric acid. The other components are hygroscopic, which means they draw and hold water from the atmosphere—the better to rust your gun.

Because of these and other drawbacks, blackpowder was replaced by smokeless powder about a hundred years ago. With the exception of The Old Western Scrounger, no manufacturer in this country offers loaded blackpowder ammunition. Interest in shooting both muzzle-loading and blackpowder cartridge guns is increasing. For this reason, there have been efforts to develop a blackpowder substitute that will work well in the old guns and their modern replicas that will give the same performance, without the problems.

Throughout the 19th century, dozens if not hundreds of blackpowder substitutes were made and sold. Their sterling qualities are evident in the fact that none are around today. Two substitutes presently on the market are Hodgdon's Pyrodex and Triple Seven, and Goex's Clean Shot.

Blackpowder and its variants do not present any unusual problems in storage. They should be kept cool and dry since they are hygroscopic. Never leave powder containers open for any length of time since this will allow moisture to enter. Never shake any can of powder. This tends to break down the granules and alter the burning characteristics. Never have any powder near an open flame or burning cigarette, cigar, or pipe. One spark in the can and you have a very sudden, very hot fire. Always keep powder in the original container. Since blackpowder is a mixture of basic elements, its life span is indefinite. Unexploded cannon shells filled with blackpowder fired during the siege of Quebec in 1759-60, detonated with considerable vigor in the early 1970s after they were discovered during construction.

## Smokeless Powder

Development of smokeless powder began in the mid-19th century, with the first really successful type being that developed by Austrian chemist Frederick Volkmann in about 1871. It was made by dissolving wood fiber in nitric acid which was later washed in water to remove the acid, then gelatinized in an ether-alcohol mixture to form a plastic colloid, now known as nitrocellulose. The powder was marketed locally and the Austrian government, in its wisdom, stuck with blackpowder and shut the operation down for not paying proper license fees.

The defining moment in the evolution of smokeless powder came some fifteen years later when the French government switched from a blackpowder single-shot rifle to a high-velocity, 8mm repeater called the Lebel. The small-bore cartridge used a smokeless powder similar to that developed by the French chemist Paul Vieille. Within about two years all of Europe had abandoned blackpowder for military rifles, and every government armed its troops with repeaters using jacketed bullets and smokeless powder. The United States was the last major power to switch to a smokeless powder repeater, when it (reluctantly) gave up the 45-70 Springfield in 1892.

Early smokeless powders were hygroscopic and, if the acid was not completely washed out, would deteriorate. Coatings were later added to make the powder more water resistant and control burning. The power of smokeless powder was further enhanced by the addition of nitroglycerin. These two types of powder—nitrocellulose and nitrocellulose plus nitroglycerin—are the two basic types manufactured today. They are known respectively as single-base and double-base powders. All smokeless powders are coated with graphite to keep them from caking, allowing them to flow smoothly through powder measures, dippers and funnels.

The outstanding characteristic of smokeless powder is that while it is of two basic types, by changing the size and shape of the granulation the burning characteristics can be varied considerably and controlled to a high degree. This gives smokeless a tremendous advantage over blackpowder, whose burning characteristics could be only roughly controlled.



**Ffg blackpowder is a fairly coarse-grained propellant. The scale above is 1 inch divided into hundredths.**



**Hodgdon's Pyrodex is an improved form of blackpowder with cleaner burning characteristics.**

Smokeless powder varies in granule size from flakes as fine as ground pepper—used in fast-burning pistol powders—to finger-size cylinders nearly two inches long for huge naval guns. The burning can be further altered by extruding powder into macaroni-like tubes, allowing them to burn on both the outside and inside at the same time. Spherical forms can be varied to exact size, while adding various chemical coatings can control the burn rate.

### Selecting the Right Powder

Modern powders are divided into three basic types on the basis of their use. These are pistol, shotgun, and rifle powders. Pistol powders are generally of the fast-burning double-base type for use in short-barreled guns. Shotgun powders are also fast burning and double-base, designed to burn completely under low pressures. Rifle powders are generally slower burning to accelerate a rifle bullet down a long barrel with maximum velocity while producing minimum pressures.

In point of fact, many powders for pistol use are quite suitable for shotguns and vice versa. Some slower burning pistol and shotgun powders will also work well for reduced velocity rifle loadings, where a light bullet and light powder charge are used.

Before buying a quantity of powder, it is a good idea to consult one or more reloading guides to see what is offered and what looks to be the best selection for your particular gun or guns. Then, buy a small can to develop your loads. If that powder proves suitable for your uses, it's a good idea to go ahead and buy larger amounts.

### Storage and Handling

Modern powders are almost completely gelatinized, making them less affected by dampness. In fact, a sample of Laf-



**The Old Western Scrounger is the only source of new, factory-made blackpowder ammunition. This lets the history buffs replicate original loads in original guns.**

lin & Rand (later Hercules, now Alliant) Unique powder was placed in storage under water in 1899 to test its viability. It was last tested in 1996. It will be tested again in this century when it is expected to continue performing as well as when it was made.

As smokeless powders deteriorate, they generate small amounts of nitric acid. Stabilizers are added to these powders to absorb acid byproduct. Most powders have fifty or more years of life before the stabilizers are used up and nitric acid begins to leach out of the nitrocellulose, leaving plain cellulose and reducing the efficiency of the powder. Occasionally powder will deteriorate owing to acid residue that was not properly washed out in the manufacturing process. Such powder will take on an unpleasant acidic smell and a brown dust looking very like rust will appear in the

powder. Powder in this condition will not shoot well, giving poor ignition and low power. It should be disposed of. Metal cans containing powder will sometimes rust on the interior, producing a very similar-appearing dust, but without the characteristic odor. This does not harm the powder and can be removed by dumping the powder on a flat piece of bed sheet, spreading it evenly, and gently blowing off the dust. The powder should then be placed in another container. An empty plastic powder bottle is good so long as it is clearly marked as to what it is. It is a good idea to mark containers of powder with the date of purchase and then use the oldest first. Opened containers of powder should be checked at

least every year for signs of rust or deterioration if they are not being used. Sealed containers should be left sealed until they are to be used. Alcohols and occasionally camphor are added to stabilize burning characteristics. Powder containers should be kept tightly closed to keep these volatile additives from evaporating into the air.

Smokeless powder is quite safe to handle because it is not sensitive to shock. The main caution that must be taken is to keep it from open flame or heat. It will ignite above 400 degrees F. Shelf storage is suitable, preferably on a second floor where temperatures remain most stable. Powder should never be stored in heavy closed metal containers that could act as bombs in case of a fire. Never have more than one container of powder open at a time. If there is a fire this—hopefully—limits it to one can.

Smokeless powder is toxic if ingested because the nitroglycerin component causes heart irregularity. British soldiers in WWI chewed smokeless powder from rifle cartridges to cause a brief though severe illness to get off the line, until medical authorities discovered this practice. Children have a tendency to taste things; smokeless powder should not be one of them.

### Loading Density

Various combinations of bullets and powder charges can be assembled to achieve the same velocity. Some are going to be more accurate than others. Various manuals will often indicate loads



The chore of blackpowder cleanup is now easier with better cleaners and treated patches.

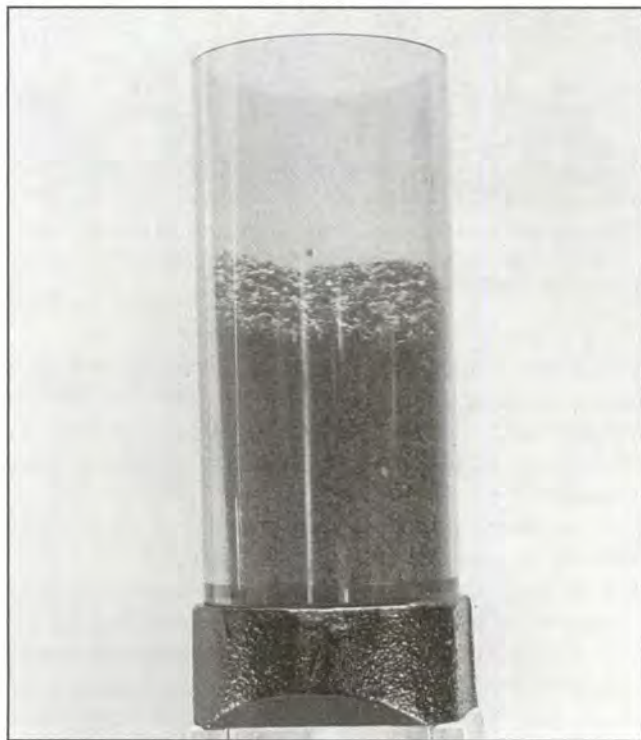

Leaving a powder measure open allows volatiles to escape and dirt to enter. Keep it capped! Never leave powder in a measure after loading or you may find yourself guessing what kind it is.



Compressed loads should be approached with extreme caution for obvious reasons.

that gave the best accuracy in particular guns. This is usually the best place to start developing a load, although such a combination will not necessarily be the best performer in your gun.

Generally speaking, when selecting a powder there are a few rules of thumb worth following. Larger-capacity rifle cartridges, with heavy bullets, generally perform best with slow-burning powders. For best accuracy, a powder charge that fills the case with little or no air space tends to give better accuracy than a small charge that can shift position in the case. Shooters using reduced loads, particularly in rifles, get better results by tipping the barrel skyward before each shot to position the powder to the rear of the case. This can also be achieved by using wads or wads plus fillers to fill up the space, but the results are usually not as good. A filler wad should never be placed over the powder with an air space between it and the bullet. The space must be filled entirely. If there is a space, the wad will come slamming against the base of the bullet with enough force to make a bulged ring in the case and often in the chamber of the gun!

### Compressed Loads

Never compress powder in a cartridge case unless such a load is recommended in a reloading manual. Compressed loads should never be more than 10 percent above the case capacity. A compression of more than this often leads to lower than desired velocities. If the compression is excessive it can actually bulge the case or cause the case to stretch in the loading process, resulting in a cartridge that is oversize or too long and will jam the gun.

### Available Powders

As of this writing, smokeless powders are available from eight manufacturers or importers. These include: IMR Powder Co. (formerly DuPont and recently acquired by Hodgdon); Olin/Winchester; Alliant Powder (formerly Hercules and now a division of Alliant TechSystems); Hodgdon Powder Co., Accurate Arms, Kaltron-Pettibone, importer of Vihtavuori powder, Norma, and Ramshot.

### IMR

IMR makes both single- and double-base powders of the flake type and cylinder type for a wide variety of uses.

**Hi-SKOR 700-X** – This is a double-base flake powder primarily designed for shotshells, but works well in many target and light handgun loadings.

**Hi-SKOR 800-X** – This is a double-base shotgun powder for heavy shotshell loads. It is also applicable to some handgun loadings.

**PB** – PB is a porous base, flake powder of the single-base type. It is used for many shotshell loads and in a number of handgun cartridges. PB works well in cast bullet loads.

**SR 7625** – Although it carries the sporting rifle designation, its main use is for shotshell and handgun cartridges. It works well with a number of cast bullet rifle loadings. It is the fastest burning of the SR series of powders.

**SR 4756** – A slightly slower burning single-base powder. It works well in some rifle cartridges, with cast bullets. The main use of this powder is in shotshells and a number of handgun loads.

**SR 4759** – This is the slowest burning powder in this series. It is a cylinder powder rather than a flake type, as are the other SR powders. SR 4759 has a very good reputation with cast-bullet shooters, working well in cases as large as the 45-70. Once withdrawn, it is back by popular demand and will hopefully stay with us.

**IMR 4227** – IMR stands for Improved Military Rifle. This is the fastest burning in the series. Like all the [MR series, this is a single-base powder of a cylinder type. It works well in small rifle cases such as the 22 Hornet, the 223 Remington, and even in big ones such as the 458 Winchester. It works well in heavy handgun loads and can be used in the .410 shotgun.

**IMR 4198** – This powder is slightly slower burning, but works very well in small to medium-capacity cases such as the 22 Hornet and 222 and 223, where it is prized for varmint and benchrest shooting. It works well in large cases including the 444 Marlin and even the 45-70.

**IMR 3031** – A favorite for the 30-30 and similar medium-capacity cases with jacketed bullets, 3031 is one of the most versatile on the market. It gives good results in cartridges as small as the 17 Remington and as large as the 458 Winchester.

**IMR 4064** – Very similar to IMR 3031, 4064 has great versatility in the 30-caliber range, performing well in the 30-06 and 308. It also works well in many of the larger rifle calibers.

**IMR 4895** – This medium-slow burning powder is very similar to the Hodgdon powder of the same number. It is an excellent performer in the 30-06, but works well in slightly reduced loads with cast bullets in rifles such as the 45-70. Excellent accuracy is produced in the 223 with this powder in bolt-action rifles.

**IMR 4320** – Originally used as a propellant for military match ammunition, it is relatively slow burning and will produce good velocities with less recoil than the faster-burning types. It is applicable to cartridges from 22 to 458.

**IMR 4350** – This is a slow-burning powder intended for large capacity cases. Its bulk fills these cases well. A favorite for the 7x57 Mauser, 30-06, 243 and 270 Winchester, 4350 is an excellent maximum load for long-range work.

**IMR 4831** – Introduced in 1971, this powder carries the same number as the Hodgdon H4831, but it is not an equivalent. IMR 4831 is faster burning than the Hodgdon product! IMR 4831 is intended for magnum rifle cartridges, although it works very well in the 270 Winchester.

**IMR 7828** – This is the slowest burning in the IMR series. It is designed for the 50 Browning, and large magnum rifle cartridges including the 300 and 338 magnums. It will work well in a number of African big-game cartridges. IMR 7828 is intended for pushing large, heavy bullets at high velocities, without raising chamber pressures into the danger zone.

## Winchester

Winchester makes double-base powders in a spherical configuration. This "ball" powder achieves controlled burning and cooler temperatures by the use of additives. The ball shape makes it flow easily through mechanical powder measures.

**231** – The fastest burning of the Winchester powders, it is for handguns and is best used for light to medium target loads. It produces excellent accuracy in 9mm, 38 Special and 45 ACP loadings.

**296** – This is a pistol powder with a fine granulation. It is most useful in large-bore handguns such as the 357 and 44 Magnums. It will also work well in .410-bore shotshell loadings.

**Super Target** – WST is a shotshell propellant for Skeet and trap shooting. Its burning characteristics make it useful for 38 Special and 45 ACP as well.

**Super Field** – WSF is a shotshell powder. It works well in 12-gauge and is the powder of choice for 20-gauge. WSF is also applicable for use in 9mm, 40 S&W and 38 Super Auto handloads.

**748** – Used in military loadings for the 223 (5.56mm) rifle, this powder offers low flame temperature for increased barrel life. It is suitable for a great variety of centerfire rifle loadings in 22- through 30-caliber.

**760** – Used with other Winchester components, 760 duplicates factory 30-06 loadings. Recommended for 7mm-08 and the new 30-06 Fail Safe bullet.

**WXR** – Excellent for 7mm Magnum loading. It is a double-base, slow-burning, extruded propellant used to achieve maximum velocities and a wide variety of rifle cartridges.

## Alliant Powders

These were formerly made under the Hercules trademark and before that Laflin & Rand. Alliant currently offers 19 single and double-base powders. Alliant says that its Red Dot, Green Dot and Unique are now 50 percent cleaner burning than previously.

**Bullseye** – A longtime favorite of pistol shooters, this flake powder works well in cases as small as the 25 ACP and as large as the 44 Magnum and 45 Colt. It is a very fast-burning powder.

**Red Dot** – Red Dot is a flake shotshell powder that also will work well in light and medium pressure handgun loads. Some shooters have gotten good results with light cast-bullet rifle loadings as well.

**American Select** – American Select is a clean-burning shotshell powder with a burn rate between Red Dot and Green Dot. Its main use is for 12-gauge target loads, but it will work well in a variety of handgun loads.

**Green Dot** – This flake shotshell powder burns slightly slower than Red Dot and has an equal variety of applications.

**Unique** – This is a flake powder with a great number of uses. It works well in many handgun loads and is considered



Winchester has replaced metal powder cans with its new plastic packaging, which keeps volatiles in and moisture out of the powder inside.

one of the most accurate in 44 Magnum and 45 Colt. It is well adapted to cartridges as small as the 25 ACP. It performs equally well in many shotshell loads.

**E3** – Alliant's newest shotshell powder is a double-based shotshell powder designed for light and standard 12-gauge target loads. Alliant promises improved pattern consistency, better gas expansion rates, higher muzzle velocities and clean-burning performance.

**Promo** – For light and standard 12-gauge target loads with economy in mind.

**Steel** – Alliant's only powder designed specifically for loading steel shotshells, as well as 2 oz. turkey loads.

**Power Pistol** – As the name implies, this powder is for handguns. The primary use is for high performance loads in the 9mm, 10mm and 40 S&W. It will make good medium velocity loads for the 380, 38 Special and the 45 ACP.

**Herco** – This is a moderately slow burning shotshell powder with application to handgun loads. The granulation is coarse and it is best for magnum loads.

**Blue Dot** – This is a very slow burning shotshell powder that also works well in magnum handgun cartridges.

**2400** – A finely granulated powder, 2400 works well in small rifle cases such as the 22 Hornet and similar varmint cartridges. One of the older powders in the line, it is still popular for magnum pistol loads in 357, 41 and 44. It produces good accuracy in reduced cast bullet rifle loadings. Care, however, must be taken not to overload, since this is a powerful powder that takes up very little space in large cases.

**Reloder 7** – This is the fastest burning of the Reloder series. It works well in medium-capacity rifle cases of the varmint class, on up to the 458 Winchester Magnum, in which it delivers excellent accuracy with heavy bullets. Reloder 7 has been a favorite with benchrest shooters for its accuracy in the 222.

**Reloder 10X** – Designed for light varmint and light bullet loads in 222 Rem., 22-250 and 223 Rem., as well as benchrest loads and light bullet 308.

**Reloder 15** – Reloder 15 is slightly slower burning than the discontinued Reloder 12. It works well in a wide range of





**Alliant Unique powder is a powerful, fast-burning double-base propellant used in pistol and light rifle loads. It is a fine, flake powder that has been made for nearly a century.**



**IMR 3031 powder is an extruded single-base propellant made of nitrocellulose. It has a fairly slow burning rate and has long been a standard for military rifle cartridges.**

rifle cases from the 223 to magnums of the 458 and 416 Rigby size. It is generally used for heavy loadings.

**Reloder 19** - Reloder 19 is a slow-burning powder that works in heavy varmint cases such as the 22-250 where it yields the highest velocities. It does well in 30-caliber cases, including the magnums.

**Reloder 22** - This is the slowest powder in the Reloder series. It is intended for large-capacity magnum rifle cases, although some shooters have obtained good results with this powder in the 220 Swift.

**Reloder 25** - Ideal for heavy magnum rifles, Reloder 25 delivers high energy for Weatherby magnums and other large capacity cartridges.

## Hodgdon

**Titewad** - This powder is a flattened spherical shotgun propellant that features low charge weights, mild muzzle report, minimum recoil and reduced residue. For 12-gauge only, it ideal for light loads.

**HP-38** - This a spherical powder developed as a propellant for the 38 Special. It works well in a variety of medium-size pistol cartridges, producing fine accuracy.

**Clays** - This is a very popular, clean-burning shotgun powder designed for light 12-gauge loads. It offers soft and smooth recoil, mild muzzle report and excellent patterns.

**Universal Clays** - This is a flake shotgun powder with burning characteristics similar to Unique. The granulation is slightly finer. Universal Clays works very well in a variety of handgun cartridges.

**International Clays** - This is an improved form of the Clays formula. It yields reduced recoil in 12- and 20-gauge target loads.

**Titegroup** - This spherical pistol powder was designed for accuracy in large cases such as 45 Colt and 357 Magnum. Powder position in these cases does not affect velocity and performance. Excellent for cowboy action, bullseye and combat shooting.

**HS-6** - This spherical powder is good for heavy shotshell loads, and works well in handgun loads in medium and large calibers when high velocities are desired.

**HS-7** - This powder is a spherical propellant that is an excellent heavy field load for game such as turkey and goose. HS-7 has also received notoriety for its adaptability in steel shot loading. HS-7 is used to load some pistol cartridges, including 357 Mag, 41 Mag, 44 Mag and 45 Winchester Mag.

**Longshot** - A spherical shotgun powder, Longshot is designed for heavy field loads in 10-, 12-, 16-, 20- and 28-gauge, and delivers magnum velocities with good patterns.

**Lil'Gun** - This .410 powder was designed to fit, meter and perform flawlessly in the .410 bore. It also has magnum pistol and 22 Hornet applications.

**H110** - This spherical powder was developed for the 30 M-1 Carbine cartridge. It works very well in medium and large handgun cartridges. It is particularly good in magnum handgun cartridges where it will duplicate factory performance in these calibers.

**H4227** - This is a single-base powder that gives excellent results in small and medium rifle cases, and does equally well in magnum handgun cartridges.

**H4198** - A single-base powder that produces fine accuracy in the 223 and similar small to medium rifle cases.

**H322** - This single-base powder has found favor with benchrest shooters using the 222 and 6mm Remington BR.



**IMR 4320** is a slow-burning single-base rifle powder for use in large-bore and high-powered rifles. The extruded grains are of a "short cut" size.

It works well in a variety of 30-calibers and even in straight-walled cases as large as the 45-70.

**Benchmark** – As its name implies, this extruded propellant was developed for precision cartridges, and performs well for benchrest and small varmint cartridges, as well as light bullet 308 Win. loads.

**H4895** - The single-base 4895 is one of the most versatile rifle powders around. It produces fine performance in calibers from the 17 Remington to the 458 Winchester Magnum. It works very well in reduced loadings, burning evenly for charges as light as 60 percent of the maximum.

**H335** - This is a double-base spherical powder that produces good shooting in 22- and 30-caliber cases.

**BL-C(2)** - This spherical powder gives excellent accuracy in the 222 and 223, and was often used for benchrest and competition shooting.

**Varget** – A small-grain extruded powder, Varget is known for its insensitivity to heat and cold, which makes it a good choice for year-round hunting. Easy ignition and clean burning help produce excellent accuracy and high velocities. Fine results have been obtained in the 22-250, 308, 30-06 and 375 H&H Magnum.

**H380** – This is a double-base powder that performs well in 30-caliber cases, but also does well in large-capacity varmint rounds such as the 22-250.

**H414** – This works well in the 30-06 and similar 30s, particularly with lighter bullets where higher velocities are desired.

**H4350** – This single-base powder is intended for large-capacity, magnum-rifle cartridges.

**H4831** – This is a single-base, extruded powder that gives the best accuracy with heavy bullets in 30-calibers and larger, though it is excellent in the 270.

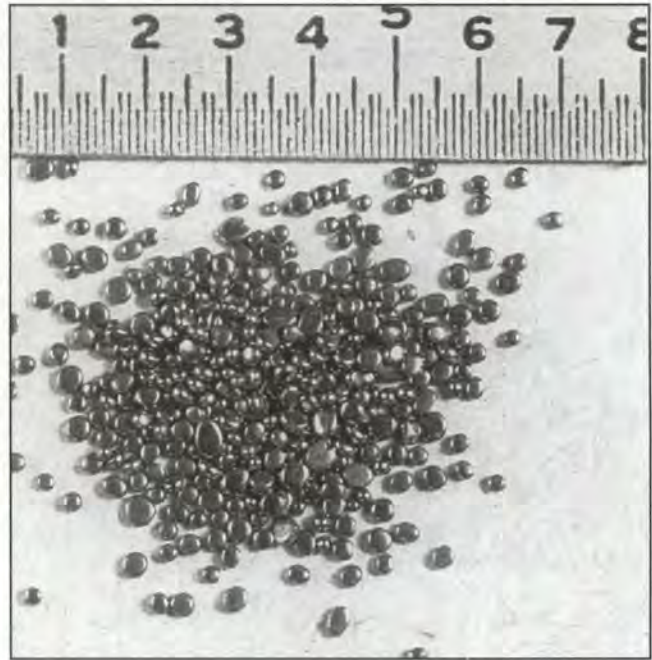

**Hodgdon BL-C(2)** is a spherical powder. It's a fast burning double-base powder with a well-deserved reputation for flowing very smoothly through powder measures.

**H4831SC** – This is the same powder as H4831, but has a shorter grain. The SC stands for "short cut." The finer granulation makes this powder flow more evenly through powder measures.

**H1000** – This is a very slow burning single-base powder. It is another that works well with heavy-bullet loads in large capacity cases.

**H50BMG** – As the name implies, this is for loading the 50 Browning Machine Gun cartridge. The burn rate is very stable in a wide range of temperatures.

**H870** – This is the slowest burning powder made by Hodgdon. Its use is limited to very large capacity cases such as the 50 BMG and a few of the large magnums for African big game use.

**Retumbo** – This magnum powder was designed expressly for very large overbore cartridges such as the 7mm Rem Ultra Mag, 300 Rem Ultra Mag and the 30-378 Weatherby Mag.

**Pyrodex** - This is a blackpowder substitute that offers cleaner burning characteristics and slightly less density. (See Blackpowder chapter).

## Accurate Arms

**Nitro 100** - This is a double-base flake powder for 12-gauge target loads. It works well in the 45 Colt and other medium to large handgun cartridges.

**No. 2** - This is a fast-burning double-base ball powder for use in the 38 Special and similar medium capacity handguns. It does well in light and target loadings.

**No. 5** - This is another double-base ball powder, slightly slower burning and comparable to Unique. It gives good results in a wide variety of medium to large handgun cases.

**No. 7** - A double-base powder intended for 9mm Luger



**Accurate Arms' Nitro 100 is a double-base flake powder best used in shotgun target shooting. It has pistol applications as well.**



**Hodgdon powder packaging.**



**Alliant Powder packaging.**

**IMR powder was formerly DuPont, then later branded IMR, and now has been acquired by Hodgdon.**

and similar medium to large capacity pistol rounds. It is clean burning and gives good accuracy at target velocities.

**No. 9** – No. 9 is a double-base ball powder and considered one of the best for the 44 Magnum. It works very well in the 41 and 357 Magnums as well. Good results have been obtained in the 22 Hornet and the 30 Carbine. It will also work well in the 410 shotgun.

**1680** – This double-base ball powder was designed specifically for the 7.62x39mm Russian cartridge. It is fast burning and delivers high velocities in the 22 Hornet. Beyond these two, its use is rather limited.

**2015** – A small-grain extruded powder of the single-base type with many uses. It performs very well in small to medium rifle cases producing excellent accuracy in many 22 centerfires. The 6mm PPC and 7mm Remington have produced excellent groups with this powder. It also does well in straight-walled rifle cases.

**2230** – A double-base ball powder with a fairly rapid burn, 2230 does well in the 223 and similar medium-capacity cases.

**2460** – This double-base ball powder is slower burning than 2230, which extends its use from medium-capacity 22 centerfire calibers to the 308 and 30-06.

**5744** – This double-base powder has a burn rate between No. 9 and 1680. It works well in pistol cases such as the 6mm TCU, 357 Magnum, 38-40, 41 Magnum, 44 Special, 44-40, 44 Magnum and 45 Colt. In rifles, it performs well in the 22 Hornet, 222, 25-20, 30 Carbine, 30-30, 308 and 30-06.

**2495** – It is a single-base extruded powder with great flexibility and gives excellent accuracy in 22 centerfires through the 30-caliber class. 2495 works well with cast bullets and produces the best accuracy in the 45-70 with cast bullets.



Reduced loadings as small as 60 percent of maximum produce consistent groups.

**2520** – A ball powder with a medium-slow burning rate, 2520 gives excellent results in many medium capacity rifle cases. Fine accuracy is obtained in the 308 and 30-06. Its pressure curve makes it suitable for use in autoloaders.

**4064** – This single-base rifle propellant is short cut for better metering while delivering the excellent performance. This propellant is intended to meet the needs of service rifle competitors and hunters who prefer extruded powders. Admirers of the 30-06 will especially like this propellant.

**Magpro** – Magpro is designed especially for the new range of very efficient short magnum rifle cartridges. Magpro has been designed to produce optimum velocities at nearly full case capacity in these calibers. Because of its uniformity of shape it has the flow required for progressive loading machines. Magpro is also a good choice for the standard magnum cartridges.

**2700** – Accurate's 2700 is designed for use with heavy bullets in the belted magnum class of rifle cartridge. It works well in the 17 Remington, 220 Swift and 22250-notable exceptions to the rule.

**4350** – This powder is equivalent to IMR 4350 and H4350. It has the same applications.

**3100** – This is a single-base extruded powder for use in medium-capacity cases. It delivers fine performance in the 243 and 7mm Remington Magnum. It works well with heavy-bullet loadings.

**8700** – This is a double-base ball powder well suited to use in medium- to large-capacity cases. Good results are obtained in the 264 Winchester Magnum, 270 Winchester, 7mm Remington Magnum, and the Weatherby 257, 270 and 300 Magnums. Good results are obtained with cast bullets, though a magnum primer is needed for consistent burning.

**Solo 1000** – This fast-burning, double-base flake powder is for shotgun use. It is similar to Bullseye and has some handgun applications.

**Solo 1250** – This medium- to fast-burning shotgun powder is primarily for use in 12-gauge hunting loads as well as trap and Skeet loads for the 20- and 28-gauge. It is similar to Unique and has pistol applications for medium-capacity cases such as 9mm and 40 S&W.

**4100** – This powder is very similar to Accurate No. 9. It is slightly slower burning and is designed especially for the .410 bore 2 1/2-inch, 1/2-ounce Skeet load. It can be used for pistols using No. 9 data with a magnum primer.

## Vihtavuori

Vihtavuori powder is made in Finland and imported by Kaltron-Pettibone. As of this writing, Vihtavuori makes twenty-two powders, both single- and double-base, for rifle and pistol use.

**N110** – This is a fast-burning powder in the class of Alliant 2400, Winchester 296 and Hodgdon H 110. It works well in the 22 Hornet and other small- to medium-case 22 centerfires. It serves well in the 357 and 44 Magnums and 45 Winchester Magnum.

**N120** – Similar to IMR 4227, N120 is designed to work well in the 22-centerfire class of rifle cartridges. Its application beyond this, however, is limited, though good results have been obtained in the 7.62x39mm Russian.

**N130** – This powder burns faster than N 120. It has applications in 22 centerfires, such as the 223, and medium-capacity cases in the 25- to 27-caliber range.

**N133** – The burning rate of this powder is close to IMR 4198. It works well in the 222 and 223, and good results have been obtained in the 45-70.

**N135** – This powder burns with moderate speed, similar to IMR and Hodgdon 4895. It is a versatile powder with applications from the 17 Remington to the 458 Winchester.

**N140** – A relatively slow-burning powder, N140 can be used in place of IMR 4320, Alliant Reloder 15 and Hodgdon H380. Best results are in 30- to 35-caliber rifle cases.

**N150** – This powder has a slow burn rate similar to IMR 4350. It works well in 30-caliber and up.

**N160** – This is another slow-burning powder designed mainly for magnum rifles. It works well with light-bullet loads and with heavy bullets in the 30-06. Good results have been obtained in the 220 Swift, 243, 25-06, 264 and 7mm Remington Magnum.

**N165** – Slightly slower than N160, this powder is for heavy-bullet loads in the 30-06 and magnums in the 30-caliber range and up.

**N170** – The slowest burning powder in this series, N 170 is suitable for large-capacity cases only.

**24N41** – This powder is especially designed for the 50 BMG. This is a single-base powder like the N 100 series, but the grain size is larger and burning rate slower.

**20N29** – Another 50 BMG powder. This one burns slightly slower than 24N41.

**N540** – This is a double-base powder with a burning rate much like N 140. It is designed for the 308 Winchester. A high energy powder.

**N550** – Another double-base powder with a burning rate like N150, but designed especially for the 308 and 30-06. A high energy powder

**N560** – The burning rate of this powder is like N 160, but it is designed for the 270 Winchester and the 6.5x55 Swedish Mauser. A high-energy powder.

**N310** – This pistol powder is comparable to Bull's-eye. Its fast burning rate lends itself to use in the 25 ACP on up to the 44 Magnum, where it proves excellent for light target loads.

**N320** – Suitable for shotshells and mid-range handgun loads, N320 works well in cartridges in the 38- to 45-caliber class.

**N330** – The burning rate of this powder is similar to Green Dot. It performs well in pistol cartridges from 38 to 45.

**N340** – This powder has a slightly slower burning rate and is similar to Winchester 540 or Herco. Good results are obtained in medium to large handgun calibers.

**N350** – This is the slowest pistol powder in the N300 series, and it lends itself to use in shotshells. In this regard, it is about like Blue Dot. Use in handguns is limited to medium to large calibers like 9mm to 45 ACP.

**3N37** – This is not really an N300 series powder. It is used in high velocity rimfire loads and shotshells. The burning rate is between N340 and N350. Good results have been obtained in 9mm, 38 Super Auto, 38 Special and the 45 ACP. Similar results have been achieved with the 357 and 44 Magnums.

**3N38** – This a powder for the high velocity loads of the 9mm Luger and the 38 Super with moderate bullet weight. Designed especially for competitive handgun shooting.

**N105** – Super Magnum. This is a special powder with a burning rate between N350 and N110. It was developed for heavy-bullet loads and large capacity cases. Best results have been in magnums in the 357 to 45 class.

## Norma

**200** – Norma's fastest rifle powder is suitable for smaller cartridges, such as the 22 Hornet and 222 Rem. Also suitable with light bullets with low velocities for the 308 Winchester.

**201** – Very good for calibers with small casing volumes relative to bullet diameter, such as 9.3x57 or 45-70.

**202** – Specially produced to give maximum performance in 7.62 NATO. Also for medium calibers such as 8x57, 9.3x62 and 9.3x74 R.

**203-B** – Usable from 22-250 to 358 Norma. Very well suited for 6mm Norma BR and 308 Win. loaded with heavier bullets.

**204** – This is a slow burning powder with good performance and high accuracy in such calibers as 6.5x55 and .30-06

**MRP** – A very flexible magnum powder for calibers with relatively large case volumes.

**MRP-2** – A good choice for overbore calibers such as 7mm STW, 6.5-284 and 6.5-06. Fine grain facilitates filling.

### Ramshot Powders

**Competition** - A double-based, modified (flattened) spherical powder that is designed



Current label for Vihtavuori powder.



Vihtavuori N350 is a slow pistol powder for medium to large calibers. It is also suitable for shotshells.

for the 12-gauge clay target shooter who is interested in cleanliness, low recoil, and consistency. Competition is a "fluffy" powder that provides a good wad-to-hull configuration and results in a tight crimp. A good choice for the cowboy action shooter.

**Zip** – This is a double-based, modified (flattened) spherical powder that performs extremely well in small- to medium-sized handgun cases. Clean, fast burning and consistent with a wide range of cartridges makes it a great choice for target and competitive shooters.

**Silhouette** - A double-based, modified (flattened) spherical powder that will allow you to make major with the 38 Super. Silhouette's low flash signature, high velocity, and clean-burning properties make it a perfect choice for indoor ranges and law enforcement applications.

**True Blue** – This is a double-based, spherical powder that performs extremely well in most handgun cases. The load range for True Blue is currently from the 380 Auto to 454 Casull. True Blue's physical size contributes to excellent meterability and consistency of charge weights when run through a progressive loader.

**Enforcer** – Enforcer is a double-based, spherical powder that produces high velocities in a wide variety of large handgun calibers. Its physical size lends itself to excellent consistency in charge weights through a progressive loader due to its meterability. Enforcer also performs well in some small rifle cases such as the 22 Hornet.

**X-Terminator** – A double-based, spherical powder that is designed for the high-volume 223 varmint hunter who demands a clean-burning powder that will not foul the barrel after a few shots. It meters extremely well, providing for an outstanding shot-to-shot consistency. Also does not bridge going into the small diameter necks of the 22-centerfire calibers.

**TAC** – A versatile rifle powder that performs well in a number of different calibers. TAC provides very high velocities in a 223 with an 80-gr. bullet and still stay within SAAMI pressure guidelines. TAC is a double-based, spherical powder providing excellent meterability and consistent charge weights.

**Big Game** – As the name indicates Big Game is used predominantly in the 270 and 30-06 classes of cartridges but it also performs well in the short-action family of cartridges. Its performance in the 22-250 and the 220 Swift make it one of the most popular powders in the Ramshot line.

**Hunter** – This ball powder provides good meterability and clean burning, and produces outstanding velocity in the 257 Roberts and the new Winchester Short Magnum family of cartridges. Hunter additionally tends not to be temperature sensitive.

**Magnum** - 1000-yard match shooters using the 6.5x284 are having exceptional results with Ramshot Magnum. Magnum's excellent velocities, coupled with its cleanliness, make it a great choice for high-volume match shooters. Formerly designated Ramshot Big Boy.

With so many projectiles available in so many shapes and sizes, how do you find the one that's best? It depends what you're looking for.

# Bullets

**BUYING BULLETS FOR** reloading is a fairly simple process. Most of today's guns are standardized in terms of bore diameter and rifling characteristics. If you deal with a knowledgeable dealer, a simple request for "some hunting bullets for my 30-30" will probably get you what you want. Unfortunately, there are dealers who are not very knowledgeable and even some who are mainly interested in unloading what they have in stock. *Caveat emptor* is still the safest position to take.

This section refers to getting the "best" bullet. The first thing you should have in mind when you go to buy bullets is a clear idea of what "best" means for your intended use. For any gun the first consideration should be accuracy. Whether it's for target or game, an inaccurate bullet is worthless. The easiest rule of thumb when it comes to buying bullets is to get what duplicates the factory loading. If you want ammunition for special purposes, which most handloaders eventually will, then you will have to do a little research. Old guns and those of foreign extraction can often be confusing in regard to what their bore and groove size

The "best" bullet for your gun is the one that shoots accurately and otherwise does what you want it to do.



Most bullets are packed 100 to a sturdy box, with the diameter, weight and style of bullet—flatpoint, hollowpoint, etc.—marked on the box.

actually is. The best information collected over the past century indicates that the most accurate bullet is the one that exactly fits the groove diameter of the barrel. In the final analysis, this is determined by slugging the bore of your gun and measuring the slug with a micrometer or Vernier caliper and getting bullets that fit.

Proper diameter bullets can most easily be determined by reading the information on the box they come in or by measurement, if you are buying bullets in a plastic bag from someone you don't know. This can be a little confusing. For instance, 22-caliber bullets for the early 22 Hornet rifles were properly .223-inch diameter. The modern ones are .224-inch. The 223 Remington (5.56mm) is .224-inch diameter, not .223-inch! Good loading manuals usually give warnings regarding groove diameters for foreign and early rifles, especially if there is a considerable variation in these within a particular type of rifle.

The Lyman manual indicates that groove diameters on the

303 British military rifles vary from .309 to .317-inch. Put too fat a bullet in one of the tight bores, along with plenty of powder, and you can create a dangerous pressure situation, in addition to inaccurate shooting. The 303 Enfield, if loaded properly, is a fine, accurate rifle, capable of turning in some excellent groups.

### Bullet Length, Rifling Characteristics

Beyond the question of bullet diameter, there is the matter of bullet length and the relationship of length to the rifling twist and how this affects accuracy. Bullets aren't identified by length, but by weight when they are sold. All other things being equal, heavier bullets of a given diameter are longer. One way to find out which bullets will work best in your gun is trial and error. Another is to limit yourself to the recommendations in loading manuals. These are only guidelines for performance for the caliber of your gun, and may or may not be satisfactory to you. Beyond this there are

also some basic calculations that may save you a lot of time and expense on bullets that don't work. Therefore, a second fact you should know about your gun, beyond its groove diameter, is the rate of the rifling twist. This can be found in loading manuals for a great many standard guns, certainly for the test guns used to prepare the data. This figure will be expressed, for example, as "Twist 1:10". This indicates that the rifling spiral makes one complete turn in 10 inches. Different lengths of bullets require different rifling twists to shoot to their best advantage. If the match between bullet length and rifling is too far off, bullets may fail to stabilize and tumble in flight. On the other hand, they can be so over-stabilized they will actually break apart in flight.

If there is any doubt about the twist rate of your gun, determining this is simplicity itself, at least with a rifle-length barrel.



Good shooting only comes when you have the correct diameter and weight.

With handguns, you will have to interpolate as best you can. Stand the rifle against a plain vertical surface such as a wall or door. Place a tight cleaning patch on your cleaning rod, but use a rod that does not have a ball bearing in the handle. Once the patch is just started down bore, mark the handle and beside it make a mark on the vertical wall or door. Push the rod down the barrel, allowing the handle to turn freely. Make a second mark at the point where the handle has made one complete rotation. Measure the distance between the top and bottom marks and you know the twist rate to a very close degree. There will always be a slight amount of slippage, but this shouldn't affect your calculations.

As a rule of thumb, longer bullets of a given caliber require a faster twist to stabilize them to the point where they shoot more accurately than shorter bullets. This is true without regard to weight or velocity.

Once you know the twist of your gun, you can calculate which bullets will likely perform best and save money by not buying those that won't. There are some elaborate computer programs to do this, but there is a very simple method that works with a pocket calculator or even paper and pencil: the Greenhill Formula. The Formula for determining twist rates was the work of Sir Alfred George Greenhill, a mathematics professor at Cambridge University who later served as an instructor at the Woolrich Military Academy from 1876 to 1906. Greenhill discovered that the optimum twist rate for a bullet is determined by dividing 150 by the length of the bullet in calibers (hundredths of an inch) and then dividing again by its diameter. The number 150 is a good choice since it allows a useful margin in the calculations. Most twist rates that are close to the formulated ideal will usually work well. The beauty of this formula is that it works very well for lead or jacketed bullets. Weight does not appear to be that critical a factor. Shape and design do not seem to have that much effect either, up to velocities of 2200 fps and, to a degree, above this. To compensate for increased rotational speed at velocities over 3000 fps, some authorities recom-

If you have any doubt about the caliber of bullets you are buying, check them with an accurate caliper and/or micrometer.

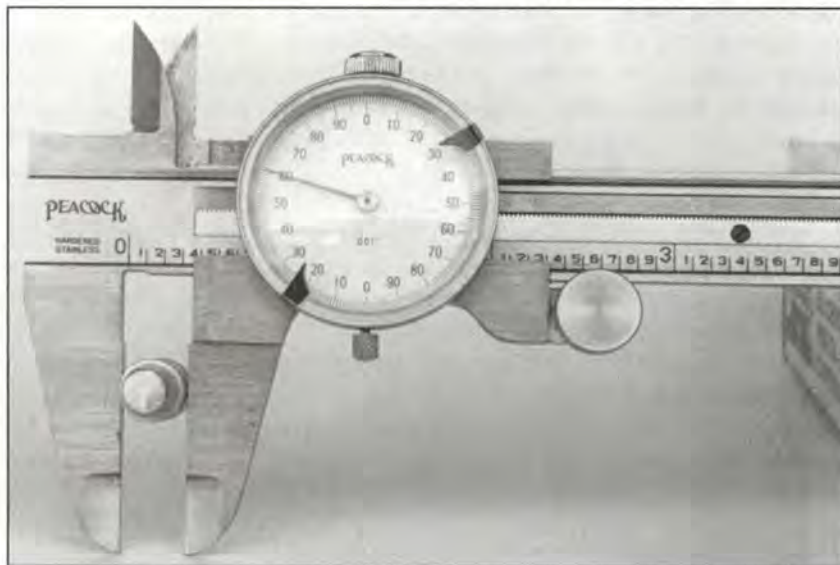



mend a slightly reduced twist rate. Although velocity does not appear to be considered within this formula, it is included in the rotation segment in a concealed form. Assume a 1:12-inch barrel firing a bullet at 1000 fps. This equals 1000 rotations per second. At 2000 fps the rotations per second double. Higher velocity yields a faster spin and is thus considered in the calculations, although it is not specifically mentioned. The most recent interpretations of Greenhill opt for a slightly faster twist with the higher velocity cartridges, in the belief that erring on the side of over-stabilization is better than under-stabilization which may result in a tumbling bullet.

The popular 223 Remington is a good candidate for study. Rifles for this cartridge are currently available with the following twist rates: 1:7, 1:8.5, 1:9, 1:10, 1:12 and 1:14 inches. To apply the Greenhill Formula using the original 55-grain bullet yields the following, for one brand of full metal jacket (FMJ) military-type bullet measuring .647-inch in length. The bullet diameter is .224-inch, which, divided into the length of .647-inch, gives 2.89 calibers long. Dividing 2.89 into 150 yields a figure of 51.90, or an ideal twist rate of



Rifling twist is important when matching bullets to a particular gun, especially with the popular 223 Remington (5.56mm). This Olympic Arms PCR-1 223 rifle comes with either a 1:8.5-inch twist or a 1:10-inch twist. Other models come in a choice of 1:7, 1:9, 1:12 or 1:14.



Ruger's Mini-14/5R 223 features a 1:9-inch twist.

one turn in 51.90 calibers. Multiplying 51.90 by the bullet diameter (.224-inch) equals one turn in 11.63 inches for this particular bullet.

The original twist for the 223-caliber M-16 rifle is 1:12 inches. In its wisdom (?), the Army decided a heavier (longer) bullet was necessary and the M-16A1 is bored with a 1:10-inch twist. The new military bullet will not stabilize in the older barrels. Bullets as heavy as 70 grains are available for the 223 Remington. For a 70-grain bullet measuring .785-inch in length, dividing by .224 equals 3.50. Dividing 150 by 3.50 equals 42.86, or one turn in 42.86 calibers; then 42.86 multiplied by .224 equals 9.60. Thus a twist of 1:9 or 1:10 inches is required to shoot this bullet accurately. There are other factors involved, such as the amount of bearing surface on the bullet, velocity and barrel length. In some cases bullets that are not well matched to twist rate can be made to function. For example, a short, 40- or 45-grain bullet, in a 223 with a fast twist of 1:9 or 1:10 inches, will perform if the powder charge is cut back. By decreasing the velocity, you can keep the bullet from tearing itself apart.

Applying the Greenhill Formula can save time and money. It can serve as a useful guide when it comes to buying a

gun or having one custom barreled, if you know in advance what kind of shooting you will be doing and thus what kind of bullets you will use.

## Rifle Bullets

Military surplus and military overrun bullets may be a terrific bargain if all you want is some cheap practice ammunition. Military bullets suitable for practice are of the full metal jacketed variety. They feature a solid lead alloy core with a copper, bronze or soft steel jacket and are referred to as "ball" ammunition. These bullets are made to military specifications and will produce reasonably good accuracy for preliminary sighting in and practice. The full metal jacket prevents nose expansion and is not good for hunting. Occasionally shooters have tried to make hunting ammunition out of FMJ bullets by filing the points off of the spitzer (pointed) military bullets, exposing the lead cores. This is a dangerous practice since the bullet already has the lead core exposed at the base. Opening the point often results in the core being blown right through the jacket, leaving the jacket stuck in the barrel. When the next shot hits the jacket, the

barrel is bulged and ruined. Don't try to modify FMJ bullets! Because of bullet-to-bullet weight variation, military ammunition will never produce fine accuracy.

In a worst-case scenario, a surplus bullet "bargain" could turn out to be a tracer, incendiary, explosive or armor-piercing type. Most military ammunition is identified by the color-coded bullet tips, and in the case of the tracer, by exposed burning material at the base of the bullet. There are various books on military ammunition that will tell you how to interpret these color codes on a country-by-country basis.

Surplus armor-piercing (AP) ammunition has been used for years as cheap practice fodder, mainly in military rifles. In his book *The Complete Guide to Handloading*, Philip Sharpe responded to the question of whether AP ammo did any harm to rifle barrels by conducting an experiment. He took a "gilt-edged" match rifle barrel, targeted it with match target ammunition, then fired a few rounds of armor piercing, and targeted it again with the same match ammunition, carefully cleaning between groups. His finding was that after the AP rounds, the match group had opened considerably and in spite of further cleaning did not repeat its former performance. This was with the AP ammunition of WWII,

not the so-called "light armor" piercing, steel-core ammunition sold today which has a far softer steel center. Would I put this newer kind through the barrel of a fine match rifle I owned? I don't think so, at least not until someone else tests it in his match barrel first. Would I use it in a \$150 AK or SKS? Sure.

Match ammunition is full metal jacketed and of a reduced-base "boattail" design. This type of bullet has good aerodynamic qualities, producing a flat trajectory that is very desirable for hitting targets at long range. Often, these match bullets have a small hollowpoint to shift the center of gravity slightly back and improve stabilization. Match bullets often have very thin jackets and are "soft swaged" to keep the jackets smooth, flawless and of the exact same thickness. Great care is taken to ensure that these bullets are all of the exact same weight and diameter. Since this type of bullet is used for punching paper targets or knocking down metal silhouettes, expansion is not needed. Even though these bullets have hollowpoints they

produces? How deep is this hole? Bigger and deeper holes are more likely to intersect with vital organs, cause greater loss of blood, and result in death.

Game bullets are generally of a pointed softpoint design, known as spitzer or semi-spitzer. These hold their velocity much better than less aerodynamic designs. Also available are hollowpoint, flat-nose or round-nose designs with the lead core exposed. Attempts at improving expansion have been tried by varying the thickness of the jacket, and by making serrations in the jacket at the bullet nose to help it split open and peel back in an even pattern as the core upsets. Other modifications are hollowpoints filled with hollow copper tubes, metal or nylon plugs which are driven back on impact, expanding the bullet.

Bullets for very large, dangerous game are subject to special requirements, since they often have to penetrate a considerable amount of muscle tissue and heavy bone to reach a vital spot. Bullets for this type of hunting feature very thick jackets. Some, like the old RWS and contem-



Eagle Arms' M15A2 Post-Ban Heavy Barrel Rifle in 223 has a 1:9-inch twist.



Remington's 40-X target rifle in 223 has a 1:14-inch twist.

are not intended to expand on game and do not. They are very prone to ricochet and are not suitable for hunting.

Bullets for varmint hunting are either of flat base or boattail design and feature a tapered or spire point with the lead core exposed and swaged into a point. The jackets are thin, allowing these bullets to expand rapidly with an explosive force on woodchucks, prairie dogs and similar-size, thin-skinned animals. This design also keeps these bullets from ricocheting when they strike the ground at velocities near 2000 fps. Because of their frangibility, varmint bullets are not suitable for large game.

Bullets for medium to large game require thicker jackets to keep them together while they penetrate deep into vital areas. They are designed for controlled expansion to allow the bullet to upset or "mushroom" as it goes deeper. This makes a large wound cavity, which renders it far more lethal than a nonexpanding type or a frangible one that breaks into fragments shortly after it strikes a body.

In medical terms, "lethality" is the effect of a particular bullet on a body. According to Dr. Martin Fackler - the leading wound ballistics expert in the country - bullet lethality is an easily understood concept. Lethality is determined by answering two questions: How big is the hole it

porary Nosler Partition, have two cores with a solid web of bronze alloy running through the center of the bullet so that in section it looks like the letter H. The top half expands, but only to the center web, which insures that the base portion will stay together. Barnes Bullets offers what they call a monolithic solid, which is simply a solid bronze-alloy bullet. Speer offers a copper-alloy bullet called African Grand Slam with a tungsten carbide dowel in the center, for use on such extremely dangerous and hard-to-kill game as Cape buffalo.

## Handgun Bullets

Handgun bullets for target use are often swaged from lead alloy and deliver good accuracy when properly lubricated. Their design ranges from a simple cylinder, called a "wadcutter" because it punches clean holes in paper targets, to round-nose and truncated-cone styles. Use of such ammunition in indoor ranges has raised fears of lead poisoning, since a certain amount of lead is vaporized from the bullet's surface upon firing. To counter this hazard, the "total metal jacket" or TMJ bullet was developed. The full metal jacket leaves an exposed lead base, while the TMJ covers the entire surface of the bullet. It's applied



**Bullets for the 22 centerfire (from left): 55-, 60-, 63- and 70-grain. They look very alike and can be easily mixed up, which is why unloaded bullets should always be returned to the original container after you are through loading ammunition. The 70-grain bullet will not work well in slow-twist (1:14-inch) barrels.**

**Match ammunition usually features a hollowpoint design and often a boattail. While these are very accurate, they are unreliable when it comes to expanding on game or varmint animals and often ricochet rather than break up when they hit the ground.**

by electroplating the bullet with copper. After plating, the bullets are forced through a die to bring them into perfect roundness. They don't expand as well as soft lead-alloy bullets and are thus a poor choice for hunting, but they do keep lead levels down in indoor ranges.

Hunting bullets for handguns are modifications of rifle designs, with some major engineering differences. Early attempts to improve handgun bullet lethality led to soft-point and hollowpoint designs based on rifle bullets. Results were unsatisfactory when it was discovered that these generally failed to expand and behaved no differently than FMJ types. In the last few years, new designs have emerged that will expand reliably at handgun velocities of 900 to 1600 fps. The secret to bringing this about was to design bullets with nearly pure lead cores, large hollowpoints and thin, relatively soft jackets of pure copper, copper alloys or aluminum. Serrations or cuts through the jacket and into the core improve expansion, increasing the lethality of these relative low-velocity bullets. Since most handgun hunting is done at ranges of under 100 yards, expansion is still reliable on most deer-size or smaller game animals, assuming that the handgun is a powerful one in the 357 Magnum to 500 Magnum class. Handguns of less than this performance level simply cannot be loaded heavily enough to do any serious hunting, and to try to "load them up" for this purpose is a foolish risk to both the gun and its shooter. Shooting any jacketed handgun bullet at low velocities is not recommended, particularly in revolvers. The greater resistance of the jacketed bullet to swaging in the barrel requires higher pressures than with lead bullets. Underpowered loads, particularly in revolvers with a generous gap between the cylinder and barrel, may result in a stuck bullet waiting to be slammed by the next one fired.

### Handling and Storage

The care and storage of bullets is much the same as for cartridge cases or loaded ammunition. Commercially made



bullets are generally packed in boxes of 100, and the boxes they come in are probably the best containers to keep them in. These are generally of plastic or reinforced cardboard and will last a long time. Obviously, bullets should not be dropped or shaken since this will impart nicks and dents which do nothing to improve their accuracy. Lead bullets are the most susceptible to this kind of damage. The early experiments of Franklin Mann, recounted in his book, *The Bullet's Flight From Powder to Target*, demonstrated the frailty of bullets when it comes to having their accuracy severely affected by even minor damage. Bullet bases are the most vulnerable. A lead or soft lead alloy bullet dropped on a wood floor and receiving a ding on the edge of the base has just been converted into scrap. They can be used for warming and fouling shots, but their former accuracy is gone.

Perhaps the most important caution with respect to bullet storage is to be careful that bullets are not mixed up. If you

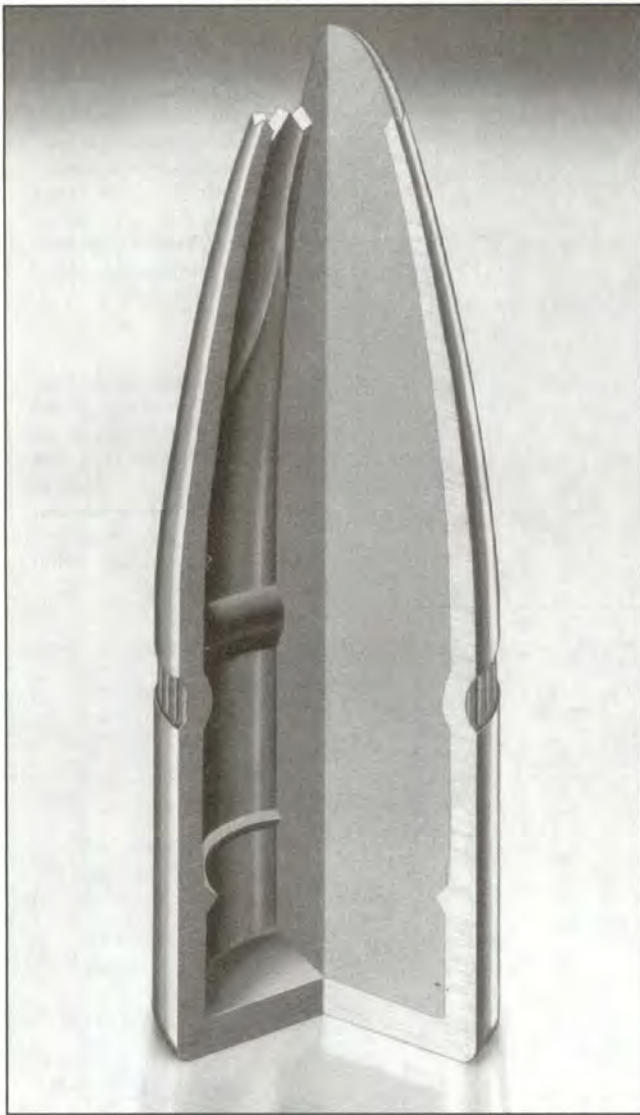

**This Hornady hunting bullet features an exposed lead point and a lead core. The core is held in place by knurled cannelures in the jacket.**



**Winchester's Silvertip hunting bullet features a thin aluminum jacket over the lead point. This allows good expansion, but prevents the bullet from getting nicked and dented as the cartridge is fed through the magazine.**

are loading two very similar calibers, there is a possibility of accidentally getting a 10mm bullet in a box of 9mms of the same style and approximate weight. You would likely catch this in the loading process at the time of seating, but there are some people who might persist in attempting to jam such a bullet into a 9mm case. Perhaps more likely is confusing same-caliber bullets but with different weights. These will seat perfectly well, but the heavier ones are going to have a higher trajectory and will land in a different place. A heavier bullet will, of course, raise pressures, and if you are using a maximum load this can have serious consequences. It is a good idea never to have two boxes of similar bullets open on your loading bench at the same time. Using boxes with snap tops or putting a bit of tape on the lid to keep it from opening accidentally is a good idea. I think most people will agree, particularly after spilling a box of the 22-caliber size and picking them all up.

## Buying Bullets

Most gun stores carry a good selection of bullets for most needs. The directory in the back of this book lists many suppliers of bullets of every description. As of this writing, bullets can be bought by mail. Most of the large bullet manufacturers such as Nosler, Sierra, Hornady and Speer offer reloading guides for their products. Data also is available from most smaller bullet manufacturers.

Custom bullets are supplied by small manufacturers and are often geared to special types of guns or for special types of shooting such as metallic silhouette competition. At times these makers or their jobbers will sell their bullets at gun shows where they can be bought at a lower cost and without the shipping and handling. A gun show is a good place to pick up information - and misinformation. Buying bullets in a plastic bag is a pig in a poke.



Pointed softpoint and flat-point bullets are both good hunting bullets. The pointed bullet is more susceptible to damage in feeding; the flatpoint loses velocity slightly faster.

Barnes X-Bullet is a solid copper projectile designed for deep penetration, no fragmentation and good accuracy. This cutaway shows construction.



Good handgun bullet designs are the wadcutter (*left*), so named for the neat holes it makes in paper targets, the round-nose (*center*) and semi-wadcutter (*right*).



Handgun bullets designed for hunting must offer rapid expansion at relatively low velocities. To this end, they feature large hollowpoints, serrated jackets and pure lead cores.

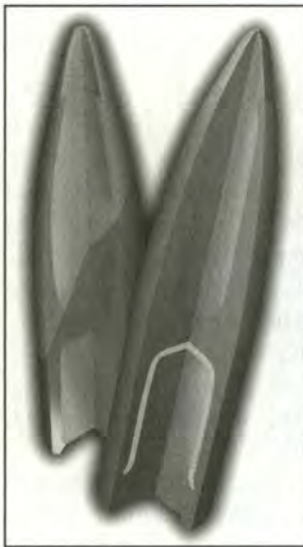

Nosler's Partition and Combined Technology Partition Gold bullets are designed so the front half expands in conventional manner, but only to the center. A heavy partition keeps the back half intact, retaining weight and energy, while an ordinary bullet might fragment.



Nosler Ballistic Tip and Combined Technology Ballistic Silvertip bullets utilize plastic tips and tapered jackets to control expansion on smaller big game and varmints. The tips also protect the bullet's tip from damage in the magazine.



Norma's new Oryx hunting bullet is a flat-based, semi-spitzer design with a thick jacket and bonded core for maximum game-stopping ability.

## Bullet Fouling

The subject of cleaning has been touched upon in the powder and primer sections, but the main fouling problem affecting accuracy is caused by bullets. To reiterate, the problem of primer deposits is one of corrosive salts. It is very similar, in effect, to the corrosive deposits left by black-

powder or Pyrodex. A water-based cleaner does a good job of getting these out of your barrel since salt and acid are readily dissolved in water and can be flushed away.

The deposit left by smokeless powder is mainly soot, graphite from the coating on the powder grains, small amounts of unburned powder and bullet lubricant. Often this is a varnish-like layer in the gun bore. It is not corrosive and does not draw water, nor does it tend to build up in thick deposits in the manner of blackpowder fouling. However, after a lot of shooting this fouling will begin to affect accuracy. It is easily removed by the many "nitro" powder solvents on today's market. These are petroleum-based and do an excellent job of dissolving lubricant and the sooty deposits of smokeless powder.

These are the steps in making one version of the Speer Grand Slam hunting bullet. A solid copper slug is punched to form the jacket. The jacket is then drawn and trimmed before the lead core is inserted. The jacket is very thick at the base to keep the bullet from fragmenting. Internal grooves and a thick base ensure the jacket does not shed the core, yet thinning the jacket in the forward portion ensures good expansion. Such bullets are for large dangerous game where deep penetration is needed.



These Speer Gold Dot handgun bullets in 38, 40 and 45 calibers evidence considerable expansion after being fired into ballistic gelatin.

Metallic fouling is basically of two types, lead and copper. Lead fouling, known as "leading," will ruin accuracy very quickly. A poorly lubricated bullet or an over- or undersize lead bullet can deposit enough lead in a barrel with one or two shots that all those thereafter will fail to stabilize and go tumbling downrange to the extreme consternation of the shooter. Exactly what causes leading is not really known and the phenomenon may have more than one cause. The original theory was that lead bullets that were too large—or were inadequately lubricated, stripped as they passed down the barrel, and that the following bullets encountered this lead, plastered it to the bore and in the process stripped off more lead. Gradually, rough clumps of lead piled up in the barrel to the point where the rifling was so clogged that it failed to stabilize the bullets. This certainly seems possible.

This theory, however, fails to explain how undersize bullets with plenty of lubricant on them can do the same thing. The second theory holds that an undersize lead bullet will not obturate the bore fully, especially if made of too hard an alloy. Hot gases rushing by this undersize bullet melt the surface, blowing particles of melted lead down the barrel. These cool and solidify, gradually building up a layer of lead forward of the chamber, which is added to by successive bullets to the point where accuracy is ruined.

In the case of undersize bullets, recovered examples show little or no rifling marks whatsoever. The surface has a semi-melted appearance and there is often evidence of gas cutting—melted channels extending forward from the base of the bullet. Furthermore, the leading in each case is of a distinctive type.

Stripping generally happens at about the mid-point of a rifle barrel—or where the bullet runs out of lubricant—and continues out to the muzzle. The deposits are streaks and clumps usually in the corner where the land joins the groove. For some reason the heaviest concentration seems to be about three-quarters of the way down the barrel. Heat soldering, caused by gas blow-by, deposits a smooth coating of lead beginning just forward of the chamber and extending eight to ten inches. Subsequent bullets burnish this coating, making it shine and it is thus difficult to see.

In either case, the problem is to get the lead out. Nitro solvents with good lubricating qualities can flow under the lead and lift it to an extent, but the process takes days. The usual practice is to use a phosphor-bronze bore brush, saturated with solvent, and work it back and forth through the barrel, making sure not to change directions until the brush has cleared each end. Failure to do so can damage the bore surface. An overnight soak, heavily coating or filling the barrel with solvent, helps speed things on a badly leaded bore. Outers, among others, sells high powered solvents containing ingredients which actually dissolve metal fouling, but there is still a lot of brush work to do.

Copper fouling is left by copper, brass, bronze and cupronickel bullet jackets, and by steel jackets plated with any of the above. Copper fouling is usually a thin wash that gradually builds into a thicker layer. Occasionally, copper alloy jackets will leave clumps of fouling which will degrade accuracy markedly and suddenly, much like leading. Removal is the same as for lead, but the process takes about three times as long. Ammonia-based solvents work well to dissolve cop-

Speer's all-plastic snap-lock boxes keep out moisture and pollutants and prevent corrosion from getting a start on the bullets inside.



Outer's Foul Out III electrochemical system is the easiest method of dealing with serious metal fouling problems.

per fouling. The usual thin buildup is barely noticeable, but after it reaches a certain point, groups begin to open up—a timely reminder it's high time for a cleaning.

Outer's Foul Out III system is an advanced cleaning process for dealing with a really bad case of fouling. Foul Out works on an electroplating system. The gun barrel is plugged at the breech with a rubber stopper, then filled with a solution containing lead or copper, depending on the type of fouling to be removed. A stainless steel rod is inserted in the barrel and held in the center by rubber O-rings. Electrical contacts are attached to the barrel and the rod. A weak current passing through the solution causes the lead or copper fouling to detach itself molecule-by-molecule to

be deposited on the rod in the center. Every so often the rod must be removed and the lead or copper scrubbed off. When the solution gets weak it, too, must be replaced. The process takes a couple of hours, but it works. All fouling is removed down to the steel of the barrel. Old layers of rust and burned-on powder varnish are loosened as well. Best of all, there is no elbow-work—nothing more than a periodic inspection. For barrels that haven't been cleaned in a long time, or those that are a bit on the rough side, it doesn't get much better. When the process is complete, a few damp patches to remove traces of the solution, followed by dry patches and preservative oil, and your barrel is as clean as the day you bought it.

Homemade projectiles have been used for centuries, but recent generations have enjoyed many advancements in the art.

# Casting Bullets

**SHOOTERS HAVE BEEN** casting bullets out of lead for hundreds of years. In the 19th century, bullet casting came into its own as a craft verging on a science. Experimenters have assembled composite bullets with hard bodies and soft/heavy noses, even going as far as pouring mercury into the mixture. (Horrors!) Those who did that died sooner or later (more likely sooner) from the poisonous vapor. Bullets for blackpowder guns were made of lead and lead alloyed with tin. The latter gave much better results because the tin improved the quality of the cast bullet, causing it to fill the mould more completely. It was found that the velocity of lead bullets could only be raised to a certain point—about 1500 to 1600 fps. At that point lead begins coming off the bullet and gets deposited in the barrel, ruining accuracy until the lead is removed. Higher velocities with conical bullets were obtained by wrapping a slightly undersize lead bullet in a thin, tough, paper jacket (much like banknote paper), which was applied wet and shrunk to a tight fit as the cloth fibers contracted on drying. Paper-patch bullets, as they were known, produced





Bullet moulds from the late 18th and early 19th century cast round balls and roughly shaped conical bullets. Most had metal handles that heated up right along with the mould blocks. The finished bullet was trimmed up with a pocketknife.

A paper-patched bullet as cast (left) and with the paper jacket applied. The grooved cast bullets are shown as cast and sized/lubricated.

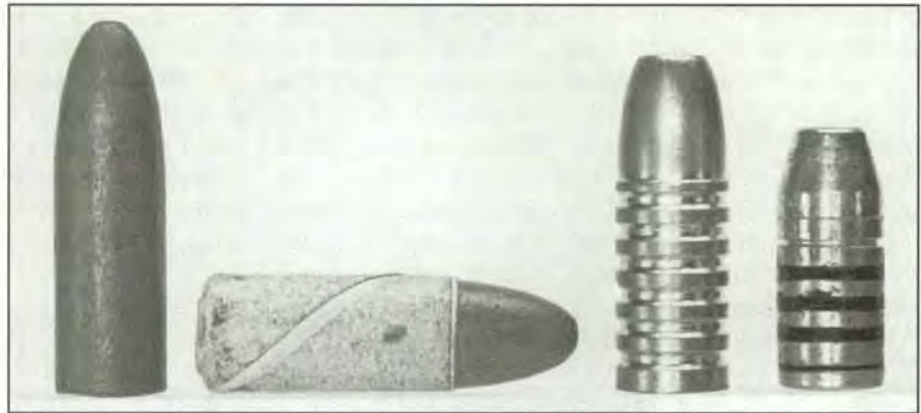

fine accuracy in addition to achieving velocities close to 2000 fps. Expansion was good since the bullet alloy could be kept soft, unlike a grooved, lubricated bullet that had to be hardened to keep it from deforming from the heat, friction and pressure of high-velocity loads. When metal-jacketed bullets supplanted lead bullets for rifle use, about the time smokeless powder appeared on the scene, paper-patched bullets all but vanished, and cast lead bullets were relegated to handguns and blackpowder rifles.

The new jacketed bullets, however, were discovered to have their drawbacks: a considerably shorter barrel life caused by erosion and wear, and a hard copper fouling. This fouling was not only difficult to remove, but often covered up the corrosive salts left by primers which ate up the barrel very quickly.

Shooters began to have second thoughts about abandoning lead alloy bullets. Unfortunately, soft lead bullets and smokeless powder are not always happy together. The higher flame temperature of the smokeless powder had a tendency to melt the bases of lead bullets. Around the turn of the century, John Barlow of the Ideal Manufacturing Company—makers of bullet moulds—came up with the idea of placing

a small copper cup known as a “gas check” on the bases of cast bullets to prevent this from happening. Following Barlow’s death, the Ideal Company was taken over by the Lyman Gun Sight Company, which began publishing some of the first good manuals on reloading. It was not until the 1930s, however, that the basics of making good cast bullets for smokeless loadings were clearly understood.

### Bullet Alloy

Hardening lead bullets with tin improved their casting quality. But tin is expensive and after adding one part to twenty parts lead, by weight, not much additional hardening was achieved. In fact, as the tin content is increased much above this point, it becomes more like solder, since the addition of tin lowers the melting point and metal fouling begins to build up in the barrel. Though antimony does not truly alloy with lead, it will combine in crystalline form and harden it to a great degree. The best hard alloys are composed of lead, tin and antimony. The tin serves to coat the antimony crystals and bond them to the lead. The antimony adds a great deal of hardness in proportion to the amount added, by weight. Tin is about twelve times as expensive

as lead, while antimony is about three times as much. The addition of both metals to lead increases its fluidity in the molten state which makes it ideal for casting type metal or bullets, both of which require hardness, toughness, and precise dimensions.

When preparing or buying bullet alloy material, it is best to first consider what purpose you wish to use these bullets for, since there is no point in spending the money to produce gold-plated ammunition for plinking. Harder bullets, particularly those hardened with antimony, tend also to become brittle. Hard alloys are a poor choice for making hunting bullets since they will either drill straight through or shatter, rather than expand evenly. Hard bullets are a good choice for long-range target use or metallic silhouette shooting where velocity and flat trajectory are important and there is no need for expansion.

Bullets made of lead, tin and antimony alloy will become harder as they age. After two weeks or so, they have reached their maximum hardness. If harder bullets are desired, one way to achieve this without adding additional antimony is to harden them at the time of casting by dropping the bullet (hot out of the mould) into a pan of cold water rather than letting it cool slowly. A bullet of wheelweight metal with a normal hardness of 12.4 Bhn can be hardened to better than twice that by the above method. Similar hardening can be done by placing cast bullets in a pan, heating them in an oven to about 500 degrees Fahrenheit, then quenching them in cold water. Hot bullets must be handled very carefully since they are soft to the point of being in a near-melted state and are easily damaged.

Bullet alloys can be bought premixed from various sources, or you can buy lead, tin and antimony and mix your own. Since antimony has a melting point almost twice that of lead, it cannot be melted over an ordinary gas stove or electric melting pot. Good bullet alloys can be made from a variety of scrap materials that can be obtained at a lower cost than

premixed alloys or pure metals. The main thing is to know what you are getting, at least as far as possible, and to avoid bad materials that will ruin your metal for further use. Zinc is poison to lead alloys because it will not mix properly and ruins the casting qualities. Bullets have been made of nearly pure zinc under such trade names as Zamak and Kirksite. Zinc alloys are generally too lightweight for shooting at long range. They tend to gas-cut rather badly because they cannot be gas-checked. Battery plates were at one time salvaged for bullet making. That was before they were made of lead and calcium that, like zinc, ruins the casting quality of your alloy. Babbitt, bearing metal with high amounts of tin and antimony, is of use mainly to harden other lead alloys. Babbitt contains slight amounts of copper, but this floats to the surface and generally does not cause serious problems when the metal is melted down.

Bullet alloys can roughly be classed as soft, medium, hard and extra-hard. Soft alloys are lead with about 3 to 4 percent tin or about 1 percent antimony. They are suitable for most handgun loads and low velocity rifle loads to about 1300 fps. Medium alloys need to be about 90 percent lead, 5 percent tin and 5 percent antimony, and are good to about 1700 fps. Hard alloys are about 84 percent lead, 12 percent antimony and 4 percent tin. This is the alloy used in Linotype, and it will shoot well at around or above 2000 fps. Extra-hard alloys can be anything up to 72 percent lead, 19 percent antimony and 9 percent tin. Beyond this, bullets begin to become too light in proportion to their size, and efficiency is lowered.

### Mixing Alloys

Alloying and bullet casting should be done in a well-ventilated place or, better yet, outdoors. The equipment needed for mixing alloy is an iron melting pot and a lead thermometer or electric melting furnace with a thermostat, a steel spoon or skimmer to stir the metal and skim off dross. A



The cast/lubricated bullet will give equal or better accuracy than the jacketed hunting bullet, while producing less barrel wear, and can be made at a fraction of the cost. At ranges of 100-150 yards, it will kill just as effectively.



Copper gas checks applied to bullets designed for them will allow increased velocities and keep hot gas from melting the bullet bases.



Block lead and tin, as well as pre-mixed alloys, ensure purity in the metal alloy. Many scrap alloys, however, may be used to make good bullets, including wheelweights, lead plumbing pipe and lead cable sheathing. Scrap 22 rimfire bullets recovered from indoor shooting ranges can also be a viable source.

This electric melting pot with bottom-pour spigot holds about 10 pounds of alloy. It's an old design that still works well.

tin can to hold the dross and an ingot mould complete the list of basics. It is a good idea to keep the alloying operations and bullet casting separate. Alloy should be made up in 2-pound lots if you are experimenting. Once an alloy is found that suits your needs and shoots well, you can make up as much as you like—the more the better to maintain bullet weight consistency.

Cleaning scrap involves removing dirt, oxides, and such extraneous items as the steel clips on wheelweights by melting it. To keep the metal fluid and separate the unwanted material, it needs to be fluxed with a piece of beeswax or paraffin the size of the first joint of your finger. This creates smoke, which can be burned off by holding a lit match in it. The metal should be stirred with a spoon or lead dipper to work the flux into the metal and bring impurities to the top. While this stirring should be fairly rapid, it should not be so vigorous as to flip or spill hot metal on yourself. Impurities will collect on top and should be skimmed after stirring and fluxing. Fluxing will work tin and antimony into the lead that would otherwise float to the top. Do not skim off the tin, which forms a silvery gray coating on the surface. When you reach this stage, flux and stir again to blend it all together, then pour the cleaned scrap alloy into moulds for bullet casting, or for blending into a harder (or softer) alloy at another time. This final fluxing and stirring assures a consistent mixture, which should be mirror bright with a few brown spots of burned beeswax on it when in the molten state. The alloy can then be poured into a mould for small ingots for bullet making. These should be remelted in a clean pot for bullet casting. Use a scribe or magic marker to mark your finished ingots so you will know what the alloy is, since they all look pretty much alike.

The hardness of lead alloys is determined by the Brinell scale (Bhn) and is tested by dropping a known weight a known distance and measuring the impact hole. Lead testers



are useful tools when making up precise alloys that will yield bullets of an exact hardness and weight. Scrap alloys are not always precise in their makeup, so they must be considered "approximate" in their composition. A quick test for pure lead is to see if you can scratch it with your fingernail. Pure lead sources from scrap include plumbing pipe, block lead and cable sheathing, although there are reports some of this may be made of a battery plate-type alloy. Scrap 22 rimfire bullets contain less than 1 percent antimony and by the time they are melted, fluxed and skimmed can be considered

Small ingot moulds are the best way to store bullet alloy. To avoid mixups, ingots should be marked to identify them if different alloys are being used.

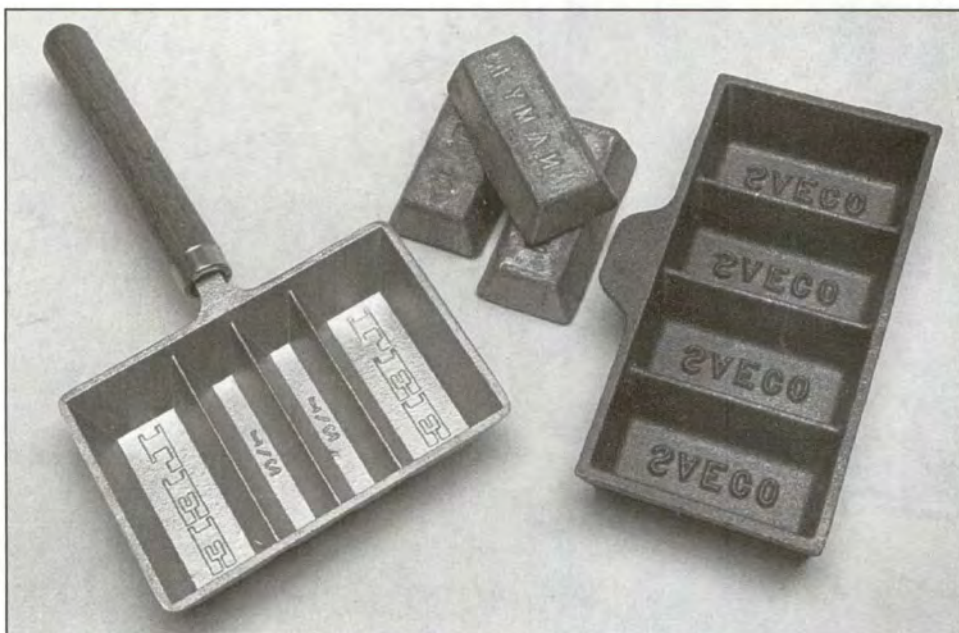

This lead and debris skimmer from Bill Ferguson easily removes clips from tire weights and similar unwanted material from the lead alloy.

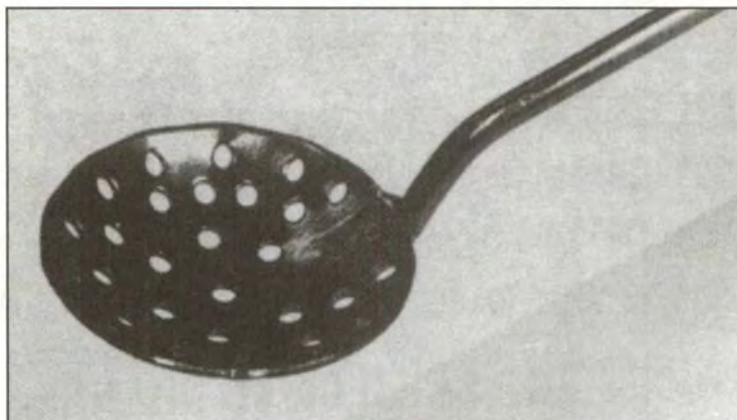

A large plumber's lead pot is best for mixing lead alloys and cleaning scrap alloy, but this one from Ferguson is better suited to the bullet caster's need.



Molten metal needs to be fluxed to remove impurities and to keep tin and antimony mixed evenly throughout the alloy instead of floating on the surface. Commercial fluxes or a piece of bullet lubricant will do the job.

## BULLET METALS AND THEIR RELATIVE HARDNESS

Alloy	-----% By Weight-----				BHN
	Tin	Lead	Antimony	Copper	
Monotype	9	72	19	—	28
Stereotype	6	80	14	—	23
Linotype	4	84	12	—	22
Electrotype	3	94.5	2.5	—	12
Tin Babbit	83	—	11	6	23
Lead Babbit	—	83	11	6	22
Tire weights	1	96	3	—	12.4
Antimony	—	—	100	—	50
Tin	100	—	—	—	7
Lead	—	100	—	—	5



The mould cavity is given final form with a cherry, a reaming tool in the form of the bullet.

The modern bullet mould is a precision tool and a far cry from the old "nut-cracker" moulds of the past. Moulds are damaged by rough treatment, and they should be kept free of rust and never battered with a metal tool.

nearly pure lead. Tin is a component of lead-tin solder and can be bought in ingots, but it is expensive.

Automobile wheelweights are a good source of alloy and can be used as is for low- to medium-velocity pistol and rifle bullets. Lead, tin and antimony alloys harden with age. The maximum hardness is reached in about two weeks. Heat-treating and quenching in cold water will harden bullets. If they are worked through a sizer, this will soften the worked surface. Tire or wheelweights, as they are often called, are now being made with slightly more lead and less antimony, and are softer, though the alloy will vary. This alloy should be tested for hardness if hardness is critical.

### The Bullet Mould

The bullet mould has two equal metal blocks with a cavity in each where the bullet is cast. The blocks are aligned by pins and held together by handles much like pliers. On top of the blocks is a sprue plate with a funnel-shaped hole, through which molten metal is poured. When the pouring is complete, the sprue plate is given a rap with a wooden mallet to pivot it to one side, cutting off the excess metal, or sprue, left on top.

Bullet moulds can be made from a variety of materials and each mould maker has his preferences for his own reasons. There is no such thing as the perfect material. Custom mould maker James Andela prefers 11L17, a leaded steel of low carbon content that machines easily to a bright smooth surface. This is the same basic type used in Lyman moulds. The material cost is low, and a cold-rolled bar is virtually free of inclusions and holes, and possesses a dense grain-structure. Oil retention is low and thus the break-in time is faster than with iron moulds.

Moulds are generally made by roughing out the cavity with a drill, then cutting the impression for the bullet with a fluted cutting tool called a cherry. The cherry makes an exact negative impression of the bullet as the mould blocks are slowly pushed together on the rotating cherry.

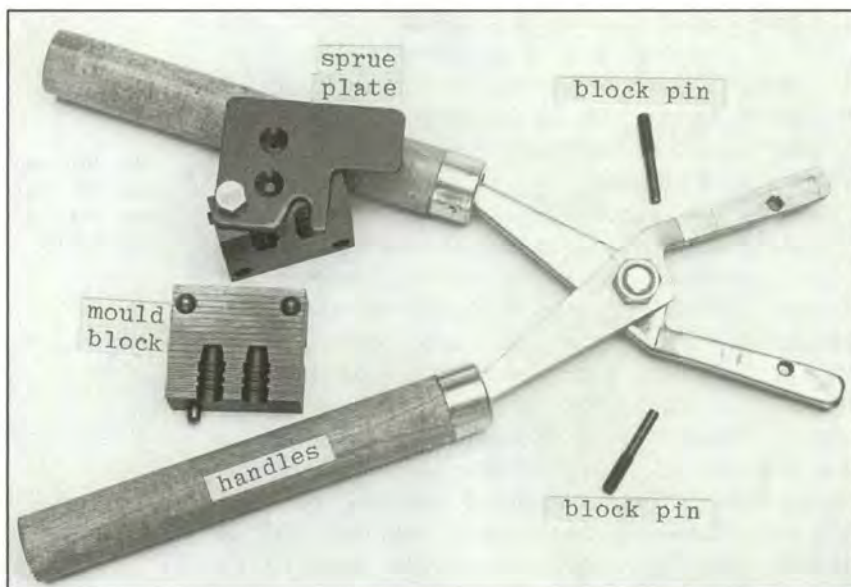



Aluminum moulds do not require as much breaking-in as iron or steel moulds. However, the cavity must often be coated with either carbon smoke or a special compound to get good bullets.

Fine-grain cast iron is a common material with the advantages of low shrinkage and easy machinability. Iron is very stable with less inclination to warp or shrink in manufacture or with heating and cooling. When an iron block is used in conjunction with a steel sprue plate, these dissimilar metals work well together to form a polishing action rather than a galling action where alike metals may tend to tear pieces from one another.

Brass and various bronzes (all alloys of copper) have been used for moulds with great success. They generally machine well and take a good finish. Copper alloys of all sorts have the added advantage of being highly corrosion resistant, and they heat quickly and evenly. The main disadvantages of brass and bronze are the cost of the material, which may be three times that of iron or steel. Brass and bronze are softer than steel or iron and such moulds must be handled more carefully to avoid damage. Any copper alloy (both brass and bronze) has an affinity for lead and tin and must be kept free of any acidic or similar material that could act as a flux and solder the blocks together in the casting process. Such an event usually finishes the mould. Nickel has been used to a limited extent in mould making and might very well be the perfect material, possessing the qualities of hardness, smooth finish, corrosion resistance and non-solderability, giving it an edge over iron, steel and copper alloys. The main problem is that it is very expensive, and for this reason no one uses nickel any more.

Aluminum and various aluminum alloys are widely used in mould making. Aluminum moulds require no break-in period. Aluminum's resistance to soldering, corrosion and its ability to heat to proper casting temperature quickly when combined with lightweight and low cost of material make it nearly ideal. The major problem with aluminum alloy is its proneness to galling. The melting point of aluminum (1200-1600 degrees Fahrenheit) is near enough to that of the lead alloys used in bullet making that the casting process has a tendency to anneal aluminum blocks, and thus soften them to the point where the sprue cutter will gall the blocks. Aluminum blocks are also subject to cutting and



This nose-pour mould from Colorado Shooter's Supply delivers a bullet with a perfect base since the cut-off is at the bullet nose.

denting. Alignment pins, usually of steel, will tend to wear aluminum blocks, unless the mould is used with greater care than an iron or steel mould. The overall useful life of an aluminum mould will be less than one of iron or steel.

### Types of Moulds

The most common mould is a simple, single-cavity type that casts one bullet at a time. The next size up is the double-cavity at about the same price as a single, for small bullets. Moulds that cast up to ten bullets at a time are known as gang moulds and are used mainly by custom bullet makers because of their speed of production. They are expensive (\$200). Moulds are also available with special inserts that will cast hollow-base and hollowpoint bullets in single-cavity blocks. Most moulds are of the base-pour variety with the bullet base at the top of the mould below the sprue plate. A few are nose-pour moulds with the sprue cut made at the



This hollowpoint plug fits into the nose end of a base-pour mould.

nose of the bullet. The theory behind these is that they give a more perfect base, since base regularity is the most important factor in accuracy with cast bullets. Nose-pour moulds are generally custom-made and intended for long-range, heavy target bullets.

While a bullet mould may look like a nutcracker, it is in reality a precision tool that can be easily damaged by rough handling. Dropping a mould can knock the blocks out of alignment, as can whacking it with any kind of tool. Bullets will, at times, tend to stick in one of the mould blocks when they are opened. To get the bullet to drop free, it may be necessary to give the mould a rap with a wooden rod or mallet. This should only be done by tapping the joint between the handles. Never strike the mould blocks themselves! This will ruin their alignment. By the same token, the sprue cutter plate on top of the mould should never be hit with anything but a wooden rod or mallet. A metal tool will damage the sprue cutter.

Moulds generally require a break-in period before they will cast proper bullets. The first step in preparing a mould for casting is to remove all traces of oil or grease from the blocks, particularly the inner surfaces. A solvent such as Outers' "Crud Cutter" is good for this purpose. Once the blocks are clean and the metal in the melting pot is free-flowing (650-750 degrees Fahrenheit), you can start casting. Remember, with a new mould it may take a couple hundred bullets before the good ones start coming. Patience is required. Aluminum blocks do not require breaking-in, but often need to be coated with carbon (smoke from a candle flame) or a special mould prep before they behave properly.

In a properly made mould, the blocks should make an almost seamless fit, with only a faint line where the blocks join. Operation should be smooth without the alignment pins binding or holding the blocks apart. The setting of these pins is done at the factory so they are usually in proper alignment. Occasionally, it may be necessary to adjust these pins into the blocks if they bind or the blocks do not close completely. Adjustment should never be more than a couple thousandths of an inch at a time. It should be done with the handle and sprue plate removed. Rarely will a mould be manufactured with the two blocks made of steel or iron from different lots that have a different coefficient of expansion. This would result in bullets with a larger side and a smaller side and a seam in the middle. Such a mould, along with a sample bullet, should be returned to the manufacturer for replacement.

After casting is finished, the iron or steel mould should be coated with a rust-inhibiting oil if it will not be used for weeks or months. A rusted mould is ruined if roughened or pitted. A solvent spray removes the oil when you are ready for the next casting session. Aluminum mould blocks don't require any special preservative action since they won't rust.

### Bullet Casting

Bullet casting is best done outdoors or in a place where there is cross ventilation or a hood with an exhaust fan to



**Bullet moulds can be warmed by placing them (carefully) on the edge of the melting pot. A pre-warmed mould will start producing good bullets before a cold one.**



**Best casting results can be had by holding the mould about an inch below the spigot rather than having it in hard contact.**

remove lead fumes. Beyond the bullet mould, a lead melting pot capable of holding about 10 pounds of metal is the center of your activity. The best method for keeping the metal the proper temperature is to use an electric melting furnace equipped with a thermostat. A lead thermometer in a plain iron pot with a gas fire under it is less convenient, but it works. The alloy temperature can vary from about 650 to 750 degrees Fahrenheit for the alloy to flow properly. Too much heat will oxidize the tin in the alloy. The metal should be stirred frequently and fluxed every 10 minutes or so to keep the mixture constant. Failure to do this will result in bullets of uneven weight. Most electric pots have a bottom-

A good puddle of metal on the sprue plate helps force alloy into the mould and keep it hot so all bands in the bullet are filled out.



pour feature with a handle that releases the metal through a spigot in the bottom. This has the advantage of getting hotter metal into the mould, leaving behind any impurities that may be floating on the top.

Bullet casting, like reloading, is a solitary activity. Children especially should be kept out of the area because of exposure to lead fumes and possible spilled hot metal. A countertop, workbench, or tabletop operation is a good set-up. Some prefer to stand while casting, while others like to sit because the activity will usually go on for a couple of hours. The melting pot must have a steady base. There is nothing like a lap full of molten lead to drive this point home. The pot is the center of activity and all other components should be laid out in neat order near the pot, all within convenient reach. These include: the bullet mould; a lead dipper with a pouring spout, if you are using an open pot; a supply of alloy ingots to be added when the metal gets low; lumps of beeswax or a container of flux powder and a spoon; matches or lighter to burn off the flux vapor; a spoon or skimmer for stirring the metal and skimming off dross; a can for dross collection; an ingot mould to recover leftover alloy; a wood mallet to rap the sprue cutter and the mould joint; a tray or box lid to catch sprue trimmings; and a folded blanket or soft rug to catch the cast bullets.

A mould should be warmed up for casting. This can be done by placing it on the top edge of the electric pot or by holding it briefly in the gas flame if you are using a stove. Overheating a mould can warp the blocks and ruin it! Never dip an iron, steel or brass mould into the pot of molten metal to warm it. To do so can result in soldering the blocks together and ruining the mould. Aluminum moulds, however, can be dipped to bring them to the proper temperature.

The actual casting process should be done in a smooth rhythmic manner. If you try for quality, speed will follow. Begin by stirring the pot, and continue to do this frequently to keep the alloy from separating and to work the impurities to the top.

Lead from the dipper or from the spigot should be



Never hit the sprue cutter with anything made of metal. A wooden dowel, in this case wrapped with rawhide, makes an effective cut without damage to the mould.

poured smoothly into the mould. Some people advocate placing the spout of the dipper or spigot of the electric pot directly into the sprue funnel. This can trap air in the cast bullet and the resultant bubbles produce bullets of varying weights with different centers of gravity. Best results have been achieved by running a fairly rapid stream into the mould and allowing the metal to puddle out over the sprue plate to about the size of a quarter. This helps keep both the mould and the metal inside hot so the bullets fill out properly. Once the cast is made, cool the sprue by blowing on it for a couple seconds. The sprue cutter should then be given a sharp rap with the wood mallet to make a clean cut. The sprue plate should turn easily on its pivot, but fit flush to the top of the mould blocks to give an even base to the bullet. If lead begins to smear over the blocks, or if the cutting of the sprue tears a chunk out of the bullet base, the bullet is still too hot for cutting. Slow down and blow a little longer. The sprue plate may tend to come loose with heating and need to be tightened. Do not over-tighten. A drop of melted bullet lubricant or beeswax should occasionally be applied to the hinge on the sprue plate to keep it moving freely. Be sure not to get lubricant into the bullet cavity.

Once the sprue is removed, the handles should be pulled apart quickly. If everything is working properly, the bullet will drop free of the mould. A soft rug or towel should be used to catch the finished bullets. These should be spread apart every so often to keep from dropping one bullet on another and damaging them. Hot bullets are very soft and should be treated gently. If you wish to harden your bullets, drop them from the mould into a pot of cold water.

When the alloy level in the pot gets about two-thirds to three-quarters of the way down, it may be a good time for a break to inspect your products and replenish the pot. The first bullets will have seams on the noses and the drive bands between the grooves will not be fully filled out, with clean, square corners on the bands. This is most likely because either the metal or the mould or both were too cold for good casting. A mould that hasn't been broken in will produce similar results, often with one half being bet-



Some examples of bullet casting problems include, left to right: mould or alloy too cool; alloy has impurities; misaligned mould blocks. A good cast bullet will have all bands properly filled out and will be shiny in appearance.

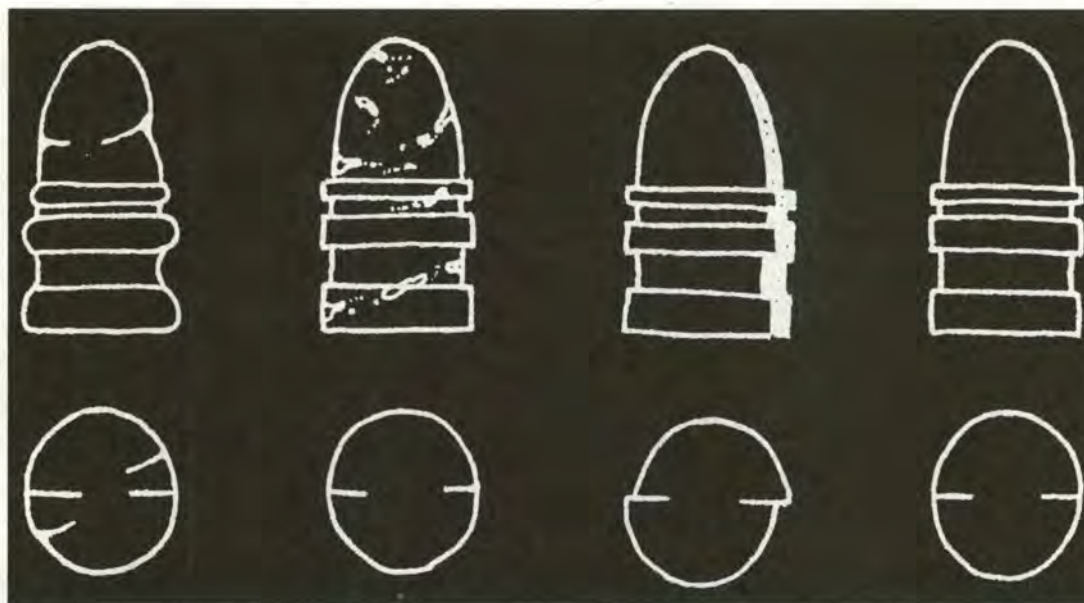

ter filled out than the other. These bullets, along with the sprues, are returned to the melt pot. Expect quite a few of these in the beginning. A good bullet will be evenly filled out everywhere. Corners on drive bands will be square and the bands will be of even width all round. By rolling a bullet across a flat surface irregularities in band width may be easily seen. Discard all those that are noticeably uneven.

Irregularities, including voids (or holes) in the bullet and drive bands not completely filled out, especially in a limited area, may be caused by oil or grease having not been fully removed from that spot in the mould. Until this is completely clean, you will not get good bullets. The burned-on oil or grease should be removed with a strong solvent and a cleaning brush or wood stick such as an orange stick (available at the nail-care area of your drugstore). Occasionally lead will become stuck on the inside surfaces of the blocks, preventing them from closing properly. Any lead smear of this sort will tend to build up unless completely removed. An orange stick and, in a bad case, solvent will remove this. Never use a metal tool, acid or an abrasive to clean the interior of a bullet mould.

Just as the temperature of the mould or the alloy can be too cool for good results, it can also be too hot. Overheating oxidizes the tin and antimony, thus changing the quality of the alloy. Bullets cast at too high a temperature or from a mould that has become too hot exhibit a dull, frosted appearance rather like the surface of a piece of galvanized sheet metal. Sometimes they will have undersize drive bands as well. When such bullets appear, reduce the alloy temperature and give your mould some time to cool off. A lightly frosted bullet generally causes no problems, but it is an indication you are operating on the hot side.

Since bullet casting is a fairly messy operation, and one that requires a certain amount of preparation and cleanup, it is best to set aside an afternoon for the project. Once you get into the swing of pouring, sprue cutting and popping the bullets out of the mould, speed will come and produc-

tion can be expected to rise to 200 or more per hour for plain-base bullets. Casting hollowpoint or hollow-base bullets is more complicated, since an additional pin or post is required to make the cavity. The hollowpoint attachment goes into the bottom of the mould and turns to lock into position. Once in place, the metal is poured. After cooling, the pin is turned for removal and the bullet is then dropped from the mould in the normal manner. The extra step takes a bit more time. The secret of good production is consistency. Fluxing and stirring of the metal often is the best way to maintain a consistent alloy mixture throughout the pot. Failure to do this will start yielding bullets of varying weights, depending where you dip from the pot. Dipping serves to stir the mixture. Bottom-pour electric pots have to be stirred or the lighter metals will float to the top.

Like any other task involving hazardous material, casting should be done with a clear head, not when you are tired. At the end of the casting session an inspection of the finished bullets should be made and the obvious duds along with sprue cuttings should be returned to the melt pot. When melted, this should be poured into an ingot mould for storage. If you are using different alloys, mark your ingots with some sort of scriber to identify the alloy so you don't mix them up.

Cast bullets are far more easily damaged than the jacketed variety and must be carefully stored. Never dump or pour a batch of bullets into a bucket or box. This will cut and nick the bases and accuracy will suffer accordingly. Good methods of storage include small boxes where the bullets can be stood on their bases, packed closely together so they don't tip over. Plastic or paper boxes are far less likely to cause damage than metal containers. Proper labeling on the box is necessary to keep things straight. The same bullet cast of different alloys will have different weights and should be kept separate. If they become mixed, it's too bad because they all look alike and the only way to sort them is by weighing each one. I'd rather be shooting!

Now that you've cast a projectile to load, you can't just seat it and shoot it. There's much more to it than that.

# Bullet Sizing and Lubricating

**AS WITH JACKETED** bullets, cast bullets and the moulds for them should be selected with consideration for the twist of the rifling of the gun you plan to shoot them in. Shorter bullets will do best in a relatively slow twist, while longer ones will require a faster twist. Beyond this is the matter of bullet design.

Cast boattail bullets will simply not work well since the unprotected, tapered base will be surrounded by hot gases and melted, with this lead then deposited on the bore of the gun. Cast bullets work best that have a flat or slightly dished base. Hollow-base bullets, in the style of Civil War Minie balls, were designed to be undersize to fit muzzleloaders and expand to bore size when fired at velocities under 1000 fps. Use of this type of bullet in cartridge guns other than handguns is not a good idea. At velocities over 1000 fps, the skirt tends to be blown out too far and may actually separate from the rest of the bullet if loaded too heavily. This can cause serious problems if the skirt remains lodged in the barrel. Accuracy in cartridge rifles is not particularly good.

Excellent accuracy may be obtained from cast bullets. Left and center are plain-base designs; the bullet on the right is designed to take a gas check.



With cast bullets, the best accuracy is generally obtained with bullets that have a relatively short ogive with the greater part of their surface bearing on the rifling. The ogive is that part of the bullet forward of the bearing surface, regardless of its shape. The greatest degree of stability is achieved with a cast bullet that has nearly all of its length in contact with the groove portion of the bore. The downside of this is increased drag and lowered velocities. Cast bullets of this design, however, are sometimes the only ones that will perform well in shallow-groove barrels. The aerodynamic shape of a bullet with a long ogive makes it a good one for long-range shooting, but such bullets are difficult to seat absolutely straight, and accuracy with cast bullets of this design is generally very poor. Much has been said in favor of "bore-riding" bullets, which offer the best compromise between the two extremes. Bullets of this design feature a relatively short drive band area with a long nose of smaller diameter that has a short taper to a point. The front portion is designed to coast along the surface of the lands—the bore—without being more than lightly engraved by them, if at all. This design provides stability without the drag encountered by a bullet with a long bearing surface, which is engraved by the rifling nearly its entire length.

### Proper Bullet Size

The importance of slugging the barrel to obtain the correct groove diameter and thus best accuracy cannot be over emphasized. If a barrel is worn or of a type known to have wide variations, this is a must. While undersize jacketed bullets can give good performance in a barrel of larger diameter, undersize cast bullets will often fail to expand or upset properly, filling the grooves, particularly if these bullets are made of hard alloy. The result is considerable lead fouling and terrible accuracy, especially with deep-groove barrels. Cast bullets that are groove-size shoot best.

With every rule it seems there is an exception. In this regard there is one that I know of, and possibly others. This exception is the 45 Allin "Trap-door" Springfield. This rifle was designed for blackpowder ammunition. It features deep-

groove (.005-inch) rifling and the groove diameter may be as deep as .463-inch. A .457-inch or even a .460-inch diameter bullet is clearly undersize. If groove-diameter bullets are used in this rifle, the cartridge case will be enlarged to the point the round will not chamber! Some frustrated shooters have gone to the extreme of having their chambers reamed out to accommodate these larger bullets. The bullets worked in the sense they didn't foul the barrels, but they developed fins of lead on the rear and were not very accurate. Springfield 45 barrels were engineered to use a very soft lead-tin alloy bullet of about .549-inch diameter, which would upset as it left the cartridge case. The purpose was to design a black-powder rifle that would shoot accurately with a dirty barrel. Each bullet would thus expand to fill whatever groove space was available. These rifles and carbines will shoot very well using lead-tin bullets of a 20:1 to 30:1 alloy. Bullets with any amount of antimony in them lack the necessary malleability to expand properly and will pile up lead in the bore. If you own an old rifle with a very deep-groove barrel and find that a groove-diameter bullet expands the case to the point where it will not chamber, a soft lead-tin alloy bullet may be the only cast bullet you can shoot in it. This was a unique design, but some of the old Bullard rifles may have also used this type of boring, and there may be others.

### Bullet Lubricants

Nobody actually knows how bullet lubricants work since there is no known way to observe a bullet as it is fired through the barrel of a gun. Unlubed lead alloy bullets can be fired at 600 to 800 fps without causing leading, assuming the barrel is a very smooth one. Revolvers, however, are something of an exception to this rule, probably because their bullets tip slightly or some gas blows by the bullets as they jump the gap from cylinder to the forcing cone in the barrel.

Lubricants prevent leading by reducing friction in the barrel, but they also have a considerable effect on accuracy. There are any number of lubricants that will prevent leading, but their accuracy record is often poor. Through the



The best rifle accuracy with a cast alloy bullet is with one that has a short ogive. The bullet on the left has many lubricant grooves and will shoot well in multi-groove and shallow-groove barrels owing to good bore contact over most of its length. The center bullet is a "bore-riding" type also with a short ogive. The right bullet is of a long-ogive design. Difficulty in getting such a bullet properly seated in the case makes it a poor shooter.

years any number of lubricant formulas have been tried with success rates ranging from excellent to terrible. Heavy grease of various sorts works well, as can be attested to by anyone who has shot some of the 22 Long Rifle ammunition made in the 1940s and early '50s. The problem, however, was that it would melt in warm weather and, when shot, combined readily with powder fouling to form a black greasy coating that wound up all over your hands. The use of such grease/lubricant in inside-lubricated cartridges ruined them in short order as the grease soaked into the powder and even into the primer, ruining both.

Grease/petroleum jelly in small amounts can be combined with various waxes with reasonable success to make a good bullet lubricant, but under warm conditions it has a tendency to "sweat" out of the mixture and get into the powder. Some greases will oxidize and harden over time, or evaporate to a degree. These are poor candidates for long-term storage if that is desired. Lithium-based

grease appears not to sweat out since it has a very high melting point.

Some early formulas for bullet lubricants included resin. Since this is an abrasive and not a lubricant, this is a bad idea. Tests conducted by Philip Sharpe, among others, demonstrated that resin in the mixture actually shortened barrel life.

Japan wax is obtained from an Asian sumac berry and is similar to bayberry wax. It was used in many early lubricant formulas. It has a tendency to dry over time and become brittle, at which point it loses much of its lubricating qualities. It is, to a degree, hygroscopic, which is not good if your bullets may be exposed to moisture. Sharpe found that Japan wax, when combined with copper-plated lead bullets, caused them to corrode to the point they were unshootable in a rather short time. Bullet lubricants that are hygroscopic or evaporate through time, allowing bullets to corrode,

**Bullets must be of the proper size and alloy to shoot well. On the left is a 45-70 rifle bullet cast of 20:1 lead-tin alloy, sized .459-inch, the proper diameter for the original 45 Springfield rifle. Next to it is the same bullet after firing. The bullet became shorter and fatter as it filled the deep-groove bore. Next is a very similar bullet sized .459-inch, but made of an alloy containing a small amount of antimony. On the far right is this bullet after firing. The hard bullet has failed to expand to fill the grooves. The rifling mark is barely visible where hot gas blew by and melted the bullet surface. The results—good accuracy from the left; a leaded bore and terrible accuracy on the right.**



are for short-term use only. About the only thing that can be done is to keep such ammunition away from heat and moisture.

Carnauba wax is a tree wax from Brazil and is the main ingredient in shoe polish. It is a hard wax that needs softening to make a good bullet lubricant. Paraffin is often included in lubricant mixtures, mainly as a stiffener. Paraffin has rather poor lubricating qualities unless heated. When subjected to pressure, it crumbles as it forms layers. It can be used in lubricants, but only sparingly.

Beeswax is hard and must be softened for bullet lubricant. In the pure form it can be used for outside-lubricated bullets, like the 22 Long Rifle, since it remains hard and will not pick up dirt and grit in the manner of softer lubricants.

Ozocerite and ceresine waxes are the same, but ceresine is the refined form, often sold as a beeswax substitute. Ozocerite is a mineral wax with many industrial uses since it is cheaper than beeswax. Candles are made of this material, often with coloring added. It is too hard to use as is and must be softened with some form of oil to make it usable for bullet lubricant.

Tallow is animal fat. In refined form it is called lard and was an early lubricant for patched bullets in muzzleloaders. The vegetable equivalent, Crisco, has long been a favorite for muzzleloader fans because it keeps blackpowder fouling soft. Tallow gets rancid and melts in warm temperatures, as does Crisco. These preclude their use in cartridge ammunition except as an additive.

Graphite is a mineral which is neither a wax nor a lubricant, but a very fine abrasive. Colloidal graphite is the finest granulation available and when mixed with waxes and oils remains in suspension. It will not burn off and has a fine polishing action and (so it has been claimed) will improve a barrel by filling pores in the metal. A little goes a long way in a lubricant, but the results have been good.

### Commercial and Homemade Lubricants

Commercial lubricants are available in sticks or blocks, with the sticks being molded to fit popular sizing-lubricating machines. The ingredients in commercial lubricants can best be described as some combination of the above in varying amounts. Prices vary, though claims of effectiveness are always high. Most give good results. The formulas are proprietary and the ingredients are sometimes referred to, or at least hinted at, in their various trade names—Bore Butter, Alox, Lithi Bee and so on.

When it comes to getting a good bullet lubricant, there is no magic formula. Most of the commercial products will do the job. They have the advantage of being cast into small cakes or sticks designed to fit into sizer-lubricator machines, and some come in liquid form which can be applied by gently tumbling bullets in it, then setting them on wax paper to dry. They are clean and easy to handle.

The advantage of making up your own lubricant is twofold - economy and versatility. Homemade lubricant is about half as expensive as the commercial product, and less



**Liquid Alox is available from Lee and Lyman. It goes on wet and dries to a waxy finish. It works well on handgun bullets, particularly those shot as they were cast.**

than that if you make it in quantity. Versatility is probably more important since, as is the case with bullet alloys, one formula is not suitable for all uses. Lubricant for low-velocity handgun bullets does not have to stand up to a lot of heat and pressure and can be fairly soft. A soft, sticky-type of lubricant is an absolute must for use with blackpowder or Pyrodex since the lubricant must keep the fouling soft and easy to remove. A very good lubricant of this type was developed by Spencer Wolf in his research on reproducing original ammunition for the 45 Springfield and Colt SAA revolver. The lubricant consists of beeswax and olive oil mixed in equal parts by volume. Beeswax must be melted in a double boiler to avoid oxidizing it. Overheated beeswax will turn dark brown and lose some of its lubricating properties. When I questioned Wolf if there was something special about olive oil, he replied that it was on sale and was thus the least expensive vegetable oil around at the time. Presumably any vegetable oil would do. These oils blend a little better with beeswax than petroleum-based oils and show no tendency to sweat out even under warm conditions. Interestingly, the beeswax-olive oil mixture does well under fairly high temperatures. The Wolf mixture is very similar in texture to the commercial SPG lubricant and a little softer than Bore Butter. Soft lubricants are the best for cold weather shooting. Hard lubricants become harder when chilled and often fail to work causing bores to lead. Harder formulas, however, are best for shooting high-pressure, high-velocity loads. Harder lubricants generally stand up under warm summer conditions where ammunition may be heated to well over 100 degrees as it sits in a box on a loading block in the sun.



Lyman Orange Magic is a stick lubricant intended for hard-alloy cast bullets to be shot at maximum cast bullet velocities and high temperatures.



LBT Blue Soft Lube is intended for shooting cast bullets at slower velocities and low temperatures.



Lithi Bee is a stick lubricant made of lithium-based grease combined with beeswax. The mixture is an old favorite.

Taurak bullet lube is a hard grease with a high melting temperature, available in sticks from NECO.

When trying your hand at making bullet lubricant, always remember to keep records of your experiments. It doesn't get much sadder than when you stumble on a perfect formula and can't remember what went into it.

### Bullet Lubrication Technique

Some bullets shoot best as cast and should be used that way if they are the proper diameter as they come from the mould. This is often the case with old guns and others that have larger groove diameters. The diameter as well as the roundness of your bullets should be checked by measuring with a Vernier caliper or micrometer.

Lubricating bullets as cast is easily done by placing them base down in a flat, shallow pan of melted lubricant, making sure that the level of the liquid covers all of the lubricating grooves on the bullets. When the lubricant hardens, the bullets are removed using a homemade tool fashioned from a fired cartridge case, of the same caliber, with the head cut off. A short case may have to be soldered or epoxied to a larger diameter case or metal tube to provide a suitable handle. Bullets are removed from the hardened lubricant by simply slipping the case mouth over the bullet and cutting it free. This is known as the cake cutter or cookie cutter method. As the tube handle fills with bullets, they are removed from the top and collected. Finished bullets should have their bases wiped free of lubricant. This is best accomplished by wiping them across a piece of cloth lightly dampened with powder solvent. They should then be placed in clean plastic boxes for storage pending loading. As bullets are run through the mixture, lubricant must be added with



each subsequent batch to keep the level at the proper height. It is best to do a full pan load each time.

### Sizer-Lubricator

Sizer-lubricators are machines that perform three functions. The first is to lightly swage (or size) the cast bullet into perfect roundness; and second to fill the grooves with lubricant. The optional third is to attach a gas check. The tools cost about \$125 to \$175.

As they come from the mould, bullets are generally larger than required, and it is necessary to bring them to the precise size for best accuracy. This is done by forcing the cast bullet through a die, swaging it to exact diameter. When pur-

A cake cutter, which is more of a cookie cutter, can be made by drilling out or cutting off the head of a fired cartridge case for the bullets you wish to lubricate. The bullets are placed in a shallow pan of melted lubricant and removed when it has cooled. The pan can be filled to lubricate all or only some of the grooves.

The Lee Lube and Sizing kit fits on their press. This sizing die and integral container is designed for bullets coated with liquid Alox. The pre-lubed bullets are pushed through the sizer and held in the container.



chasing a bullet mould and a sizing die, it is a good idea to get a mould that will produce bullets very close to the proper final size. There will always be a certain amount of shrinkage of the bullet as it cools in the mould. If this did not happen, extracting this bullet would be nearly impossible. Moulds are sold with an indication of the cast size, but this will vary depending on the composition of the alloy that is being cast. Bullets should not be sized down much over .003-inch. Excess sizing tends to distort the bullet and adversely affect accuracy. While sizing gives a bullet a shiny mirror-like surface, it also reduces the hardness of the surface by working the metal; another reason to avoid excess sizing.

Sizer-lubricators are made by several manufacturers. They all combine the same basic features: a frame to hold the die, a handle that drives the top punch that forces the bullet through the die, and a lubricating pump that holds a stick of bullet lubricant and forces it through holes in the sizing die and into the grooves of the bullet. One nice feature of the machines made by Lyman and RCBS is that the dies, top punches and lubricating sticks are all interchangeable.

The sizer-lubricator is a bench-mounted tool for it must have solid support. Otherwise the force delivered to the operating handle would lift it off the bench or take the top off a flimsy table. The tool should be bolted to the loading bench or to a solid plank and held on a sturdy table with C-clamps. Soft alloy bullets size rather easily, while those of Linotype metal require far more force. Using these machines takes a bit of skill, much like bullet casting, but mastering it is not very difficult, and speedy production will follow once you master the basics. The first step is to be sure you have the proper top punch. A flat-point top punch will mash the nose on a round-nose bullet, and too large or too small a punch will produce its own distortions, including inaccurate alignment in the sizing die. Top punches should be matched to particular bullets. Loading manuals, particularly those dealing with cast-bullet shooting, include data on the proper top punch for various bullets. Sometimes the exact form of punch is not available. Two solutions are to get the nearest larger size and pack it with varying amounts of aluminum

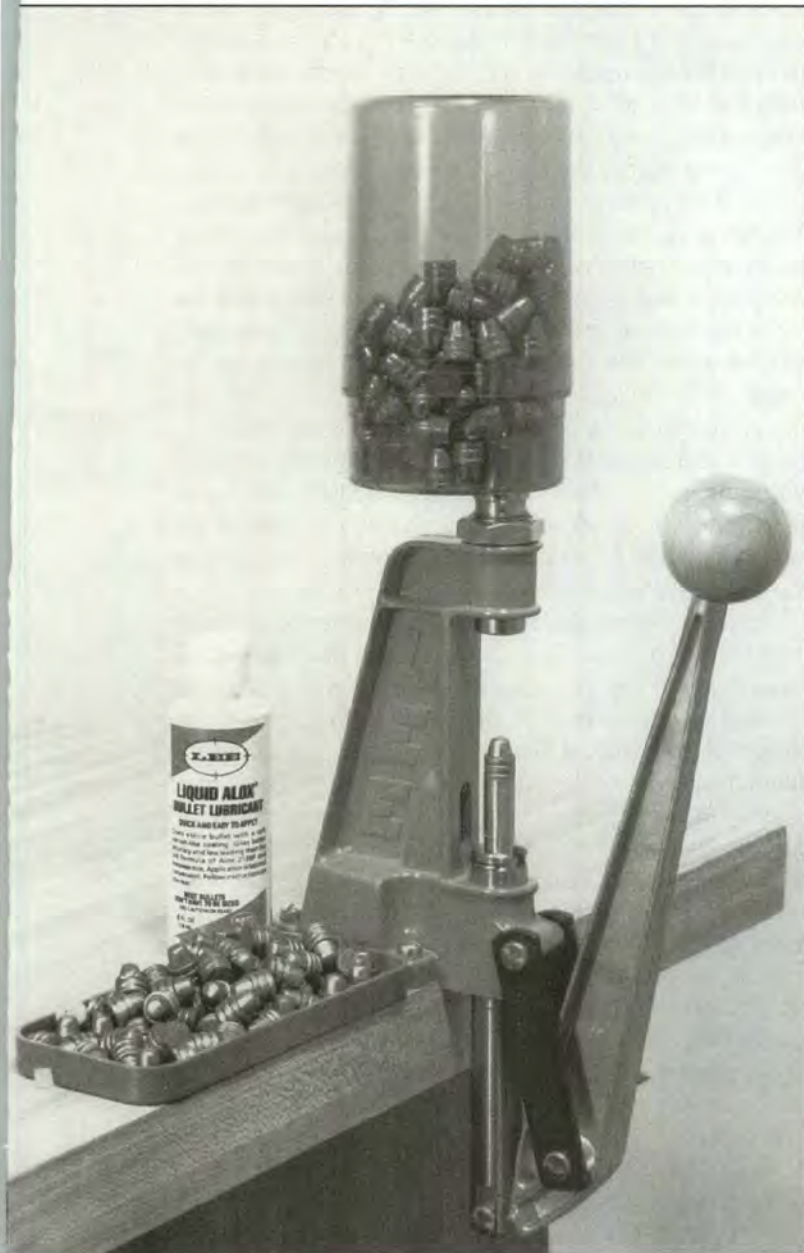

The Lyman #450 sizer/lubricator uses a hollow stick of lubricant. Dies are sold separately.



foil or facial tissue coated with a bit of bullet lubricant. Once this is compacted by sizing a few bullets, it will remain in place for a long time and not change shape. The other method, if the top punch is only slightly undersize, is to chuck it in a drill or metal lathe and re-contour it with a file, cutting tool or emery cloth. This may be necessary if you are using an obsolete or custom bullet mould.

Once the proper top punch is selected, the reservoir of the lubricator pump should be filled. Most take a solid or hollow stick of lubricant. If you are making your own, you can either cast your own sticks in homemade moulds fabricated from the proper size of pipe or you can try pouring melted lubricant directly into the reservoir itself. This must be done with the sizing die in the up (closed) position, otherwise melted lubricant will come welling up through the die to run all over the place. Pouring into the reservoir is difficult, particularly if it is of a type that uses a hollow lubricant stick and has a metal pin in the center. A pouring pot with a long spout is the only kind to use to avoid spilling lubricant all over. Solid lubricant is very difficult to remove—a putty knife will lift it off a flat surface. It is nearly impossible to remove from a rug. With the reservoir filled and the die in the down position, the lubricator pump handle is pushed two or three times to force lubricant into the die chamber. A bullet is seated in the center of the die and the operating handle is pulled firmly down forcing the bullet into the sizing die. Once sized, the handle is pushed back and the bullet pops up—the proper size and with the grooves filled with lubricant. The die must be adjusted, however, for the length of the bullet you are lubricating. This is done with an adjustment screw on the base of the lug that holds the die. If a short bullet is pushed too far into the die, lubricant will squirt up over the nose. If a long bullet is not seated deep enough it will not get far enough below the level of the lubricating holes in the sizing die, and some of the grooves will not be filled with lubricant.

The up stroke on the operating handle should be faster than the down stroke. This avoids having the bullet in the down position too long. Quick operation avoids lubricant building up on the base of the bullet and the face of the bottom punch where it has to be wiped off. The lubricator pump handle has to be given a couple of turns about every other bullet to keep the pressure high enough to fill all of the grooves completely. Oftentimes the bullet has to be run through the die a second time to fill all the grooves. One advantage of the Redding/ SAECO tool is that the lubricant reservoir has a spring-powered top on it, which keeps constant pressure on the lubricant, allowing the operator to lube several bullets before having to run the pump handle. This is essentially all there is to it. The trick to not smearing lube all over the bottom punch and bullet base is not to have too much pressure on the lubricant, and to bring the bullet up out of the die as quickly as possible. Always keep pressure on the handle after completing the down stroke. Failure to do so will allow lubricant to squirt in under the bullet. It is a matter of practice and developing a feel for this operation.



Lube/sizer dies and top punches are interchangeable between Lyman and RCBS.



A bullet pops up after having been lubricated on a SAECO machine. A solid mounting is needed to keep the machine from lifting off the bench top. Proper die adjustment is necessary to keep lubricant from squirting over the bullet nose. The small amount seen here can easily be wiped off.

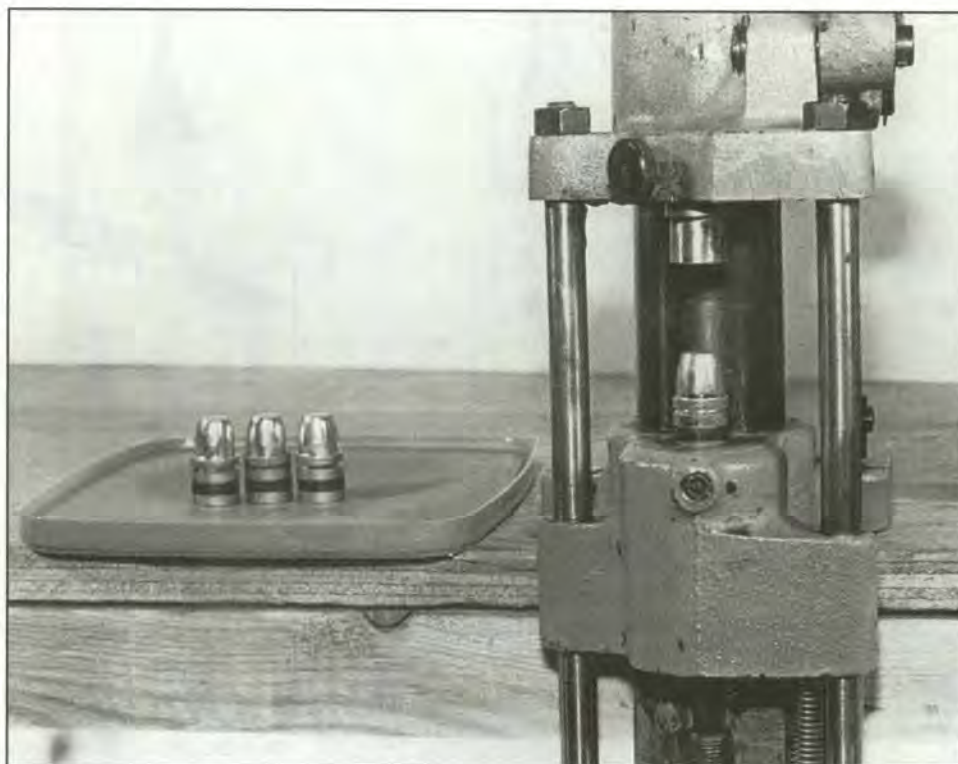

### Seating Gas Checks

Gas checks are intended for use on specially designed bullets. They are of two basic types: the Lyman type that is intended to drop off the base of the bullet shortly after it leaves the muzzle of the gun, and the Hornady crimp-on variety that remains attached until the bullet reaches the target. I prefer the Hornady type since I feel they do a better job of keeping hot gas from getting around the base of the bullet and melting channels in the bearing surface—known as gas cutting. Sometimes the drop-off gas checks do not drop off and remain on the bullet all the way to the target, making that bullet several grains heavier than the others in the series of shots and, particularly at long ranges, causing it to hit low.

Gas checks permit cast bullets to be driven almost as fast as jacketed bullets, about 2200 fps, by acting as a hard gasket at the base of the bullet. High velocities with gas-checked bullets are obtainable only with hard, tough alloys and lubricants that will stand up to high temperatures and pressures. Applying gas checks to hard alloy bullets takes more muscle than for softer ones, but can be done so long as those alloys are no harder than Linotype (bhn 22).

Seating gas checks is simplicity itself. They are placed on the face of the die punch and the bullet is seated in it. It is then pushed through the sizing die, and the bullet lubricated in the normal manner. Make sure that when the bullet bottoms in the die that it does so firmly in order to get a good fit with the crimp-on type of gas checks. When applying gas checks to soft alloy bullets, care must be taken not to apply too much pressure and flatten the nose of the bullet. The leverage on these machines is very good, allowing you to apply a great deal of pressure with minimal effort.

### Bullet Inspection and Storage

Bullets should be inspected after they come out of the sizer to see that the grooves are well filled with lubricant. Sizing will not make out-of-round bullets perfect. If the grooves are wider on one side than they are on the other, this bullet was not completely filled out in the mould. These and ones with irregular drive bands should be scrapped if they are really bad, or separated for use as warming and fouling shots. Finished bullets should be loaded immediately, or stored in closed containers where they will not gather grit, lint and other foreign matter. Bullets that have been dropped on the floor and dented on the base will no longer shoot straight. Those that have rolled on the floor through primer ash, metal filings and the like should be wiped clean with a soft cloth moistened with solvent or light oil and relubricated.

Finished bullets should be weighed on your powder scale. The finest consistent accuracy is from those that are within a tolerance of  $\pm 0.5$  grain in weight. Changes in alloy and temperature, lack of stirring and fluxing can affect weight by varying the content of the alloy in that particular bullet. By the same token, pouring technique can trap air bubbles in bullets and alter their weight. Bullets should be sorted by weight and stored and marked accordingly for best accuracy. It is best to handle finished, cast and lubricated bullets as little as possible. This keeps them clean, and your fingers won't wipe lubricant out of the grooves.

### Wads and Fillers

Distortion of the base of a cast bullet, particularly a rifle bullet, is a constant problem. Smokeless powder of the coarser granulations will be forced into the base of soft alloy

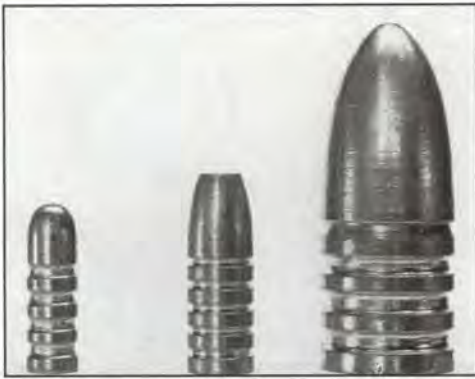

**Bullets should be inspected before sizing and lubricating. Good cast bullets should have square edges and even grooves.**



**After lubrication, there should be no evidence of distortion or pieces of lead in the lube grooves. The accurate bullet is one that leaves the barrel evenly rifled, with no asymmetrical distortion.**



**The SAECO Lubri-Sizer is a quality tool that will last a lifetime.**

bullets peppering them with small dents and often gas-cutting the sides to a degree. A number of strategies to overcome this problem have been tried with varying degrees of success. One thing seems absolutely clear, however: Never have an airspace between any kind of wad and the base of the bullet! This will cause that wad to come slamming forward to strike the base of the bullet and expand there. This can make a ring in the case and, in many instances, in the chamber of a rifle and ruin the barrel. I have had light tufts of kapok weighing about a grain, used to keep a light charge of powder in the base of a 45-70 case, make a ring in the case. These were propelled by 9 grains of Unique when they hit the base of a 150-grain bullet. Wads of felt, cork and cardboard have been used with success in straight-walled cases. Never put any kind of filler wad in a bottleneck case! All wads, however, must completely fill the void between the powder and the bullet base. Fillers between wads such as Cream of Wheat have also been tried and the results found unsatisfactory.

From time to time there is a resurgence of interest in various types of lubricating wads for use with both cast and jacketed bullets. Wax wads and grease wads have demonstrated effectiveness in improving accuracy and lengthening barrel life. These consist of a thin disc of bullet lubricant cut to exact case-mouth diameter. The lubricant is generally harder than that used in a lubricating pump. The discs are punched out of a flat sheet about the thickness of the cardboard on the back of a writing tablet. One of the better-known formulas was the development of Edward A. Leopold and was sold as "Leopold's Oleo Wads." They consisted of (by weight) 5 ounces each of Japan wax and beeswax, 2 ounces ozocerite, and 3 to 4 teaspoons Acheson

Unctuous graphite #1340. According to G.L. Wotkyns and J.B. Sweany, the developers of the 220 Swift, grease wads directly behind the jacketed bullets decreased erosion and improved accuracy.

Lubricated cardboard wads were at one time loaded in rifle ammunition by UMC and Winchester for the 40-70 and 40-90 blackpowder cartridges. Bearing the above warnings in mind, those who wish to experiment with making their own wax wads will find that about the only way to get an even sheet of lubricant is to take a very clean straight-sided glass bottle, fill it with cold water and dip it straight down into a pot of melted lubricant. A deep narrow pan and a bottle that nearly fills it will be most practical. The thickness of the layer is controlled by the number of dips. When the lubricant layer on the bottle is well cooled, a straight cut is made down one side and the sheet is gently peeled off. Wads may be cut by using the mouth of a fired case from which the head has been cut to facilitate removal.

As can be deduced, the easiest and safest kind of loading for use with a wax wad is one in which the case is nearly filled with powder and the wad and bullet base gently compact the charge. Sharpe makes the point that the wad should "stay in the neck of the case." Amen to that. For reduced charge loadings you could try sticking the wad to the bullet base by either warming the bullet base and pressing the wad in place, or wetting the wad surface with a volatile solvent and "gluing" it in place with the melted lubricant. This system is not tried or recommended. Before loading any such ammunition, see how tight the bond is. If the wad drops off or can be easily removed by slipping it or tapping the bullet, don't load it unless it is supported by a charge of powder or a solid wad column of felt, cardboard or cork.

Reloading can be accomplished in any number of ways—from simple inexpensive hand tools to costly progressive equipment. By defining your goals, you'll find which is best for you.

# Tooling Up For Reloading

**RELOADING BEGAN WITH** relatively simple tools that could be carried in the pocket or saddlebag. They were shaped in the manner of pliers and leather punches, and were referred to as “tong tools.” Manufacture of this type of equipment more or less ceased about twenty years ago, with Lyman and Lee being the only major manufacturers of this type of tool today. They are portable, cheap and capable of turning out rather good ammunition. The disadvantages are that they are slow and require more muscle power to use than bench tools. As “campfire” ammunition making became more a thing of the past, these tools have all but disappeared. They are, however, useful since you can't take a reloading bench into the woods, and there may be some instances where you might need to produce some quick loads in the field. They qualify nicely as survival equipment, too.

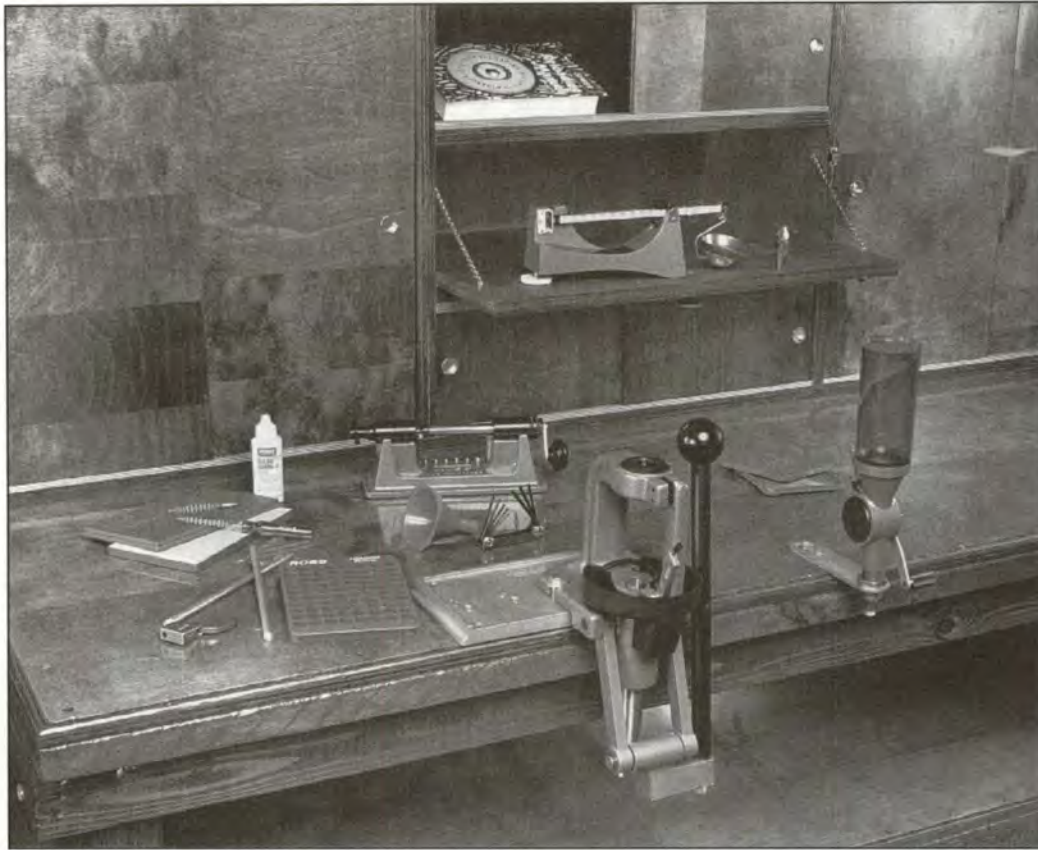

Whether plain or fancy, the reloading bench should have enough space for efficient tool mounting.

Today's reloader generally does not have all that much spare time and usually prefers speed in production over the option of taking tools to the field. The beginning reloader is faced with some basic issues that must be assessed when it comes time to purchase equipment. These include economy versus speed; speed versus precision; and, finally, precision versus economy. These three issues will be discussed in detail in the hope that you can reach decisions that will match your temperament and shooting habits. The beginning reloader can find himself stunned by information overload while perusing catalogs, absolutely brimming with gadgets and gizmos, all promising more/better/faster.

### Basic Equipment: Getting What You Need

One way to enter the water, as it were, is to get acquainted with other reloaders and see what they use and don't use, and quiz them on the whys and wherefores of their equipment. Ask a friend if you can try his equipment. This way you can get a feel for the tools, how they work, and begin to come to some decisions regarding what you might like and what you find difficult or unnecessary.

The reloading bench is the foundation of your work area. There is no standardized design, and it may well serve a dual purpose as a kitchen counter on which reloading tools are temporarily mounted. If you must use a temporary surface of this type, your reloading press and sizer/lubricator should be permanently mounted on a solid 2x6 or heavier plank that can be securely attached to the counter top with C-clamps. The counter must have a solid top since the levering



A basic reloading bench should be sturdy and have plenty of storage space. The individual design is up to the maker. This bench was built from plans available from the National Reloading Manufacturers Association.

force exerted on the bullet sizer and the loading press can pull the counter top loose. If you have the space, a solid desk or workbench arrangement is best. General requirements are that it have enough weight or be attached to the floor so that it will not rock back and forth in use. It should be solid



**Basic O-frame presses are reliable, rugged and easy to use. The Redding (left) and RCBS are typical examples.**

enough that the top will not pry loose under the stress of cartridge and bullet sizing. Whether or not it is to be a thing of beauty depends on how much of the public will view it, in a dining room or corner of an apartment, or if it will stay in a garage or basement area. If ammunition and powder are to be stored in the same area, I recommend placement of the bench in a spot that is climate controlled. It should have at least one large drawer and be close to shelving or cabinets where bullets, primers, powder, cases, loading manuals, etc., can be located within easy reach. The top should be smooth and free of cracks, holes and splinters.

While you can build a bench of your own design out of whatever scrap lumber you have at hand, an easier way is to get plans from the National Reloading Manufacturers Association. If you're handy with tools, you can buy all the components from your local lumber yard or building materials store for around \$100 and assemble it yourself.

The NRMA bench is heavy, solid and able to support all manner of tools and presses. The plans have been around for more than 20 years, and thousands of reloaders have built them. The plans call for heavy dimension lumber and plywood, so build it where you will use it.

Once you have your bench, the next step is to choose the basic reloading tool, the heart of your operation—the press. Before parting with any money, it is best to start with the maximum amount of experience and knowledge. This returns to the above-mentioned issues of speed, economy

and precision. Your first question should be: Am I going to load for pistol, rifle or both? Shotgun reloading requires its own special loading equipment and will be dealt with later. If the answer is to reload both handgun and rifle cartridges, then you will want to buy a press that is intended for rifle cartridges that will do handgun ammunition as well.

#### **Economy Versus Speed**

The most basic type of bench-mounted loading press is the O-frame or C-frame press, so called because the frames are shaped like these letters. Both are rugged and simple. They are also referred to as single-stage presses since they mount a single loading die in the top. Each operation—decapping and sizing, neck expanding and bullet seating—requires that the die be unscrewed and the next die screwed in place for each operation. The manufacturers promise a production rate of about 100 finished rounds per hour.

Similar to these are the arbor presses, which mount a single die in the bottom. Arbor presses require a special straight-line type of die that is not compatible with the top-mounted variety used in standard presses. The price range and speed are about the same. Arbor presses are small and compact, and have the advantage of being on a flat base and not requiring permanent bench mounting. This makes them handy to take to the range where ammunition can be fabricated while you shoot. In addition to instant gratification, this portability saves time and material put into long runs of



The Ross & Webb Benchrest Press is an extremely strong C-frame design for the serious reloader.



Forster's Co-Ax B-2 Press is a different wrinkle on the C- and O-frame designs. Dual guide rods offer precision alignment; dies snap in and out for quick, easy changing.

test ammunition.

More expensive and faster are the turret and H-frame machines that allow a full three-die set to be mounted along with a powder measure. All dies are in place and the cartridge is moved from one station to the next, or the turret is rotated to bring the next die into position. Production is estimated at 200 rounds per hour, but the price is higher.

Near the top end, short of buying an ammunition factory, are the progressive loaders. These are semi-automated machines with feed tubes and hoppers that are filled with cases, bullets, primers and powder. Once the various feeding devices are filled, the operator simply pulls a handle and manually feeds one component, usually bullets or cases, inserting them into a slot on a revolving plate, and the machine does the rest, moving the case from station to station. The finished rounds come popping out at the end of a full plate rotation cycle and are collected in a convenient bin. Production rates are from about 500 rounds per hour to 1200. Plan to do a lot of shooting if you invest in one of these. You should also plan to have plenty of space since a progressive stands better than 2 feet high and weighs up to 50 pounds.

### Speed Versus Precision

All of the presses mentioned will produce high quality, precision ammunition, or at least as precise as you make it, since quality control is up to the operator. Careful adjust-



The Jones arbor press is typical of the type. Arbor presses are compact and do not need to be bench-mounted, making them convenient to take to the range to assemble ammunition on the spot.

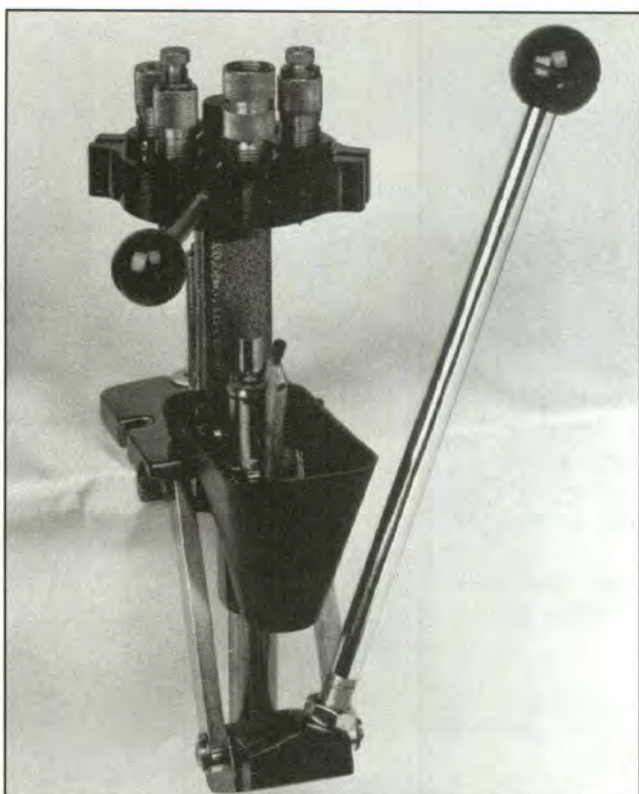

The Lyman T-Mag II is a turret press from a company that has been making this basic design for over forty years. A full set of dies and a powder measure can be screwed into the turret, and each one is then rotated into position for the next step.

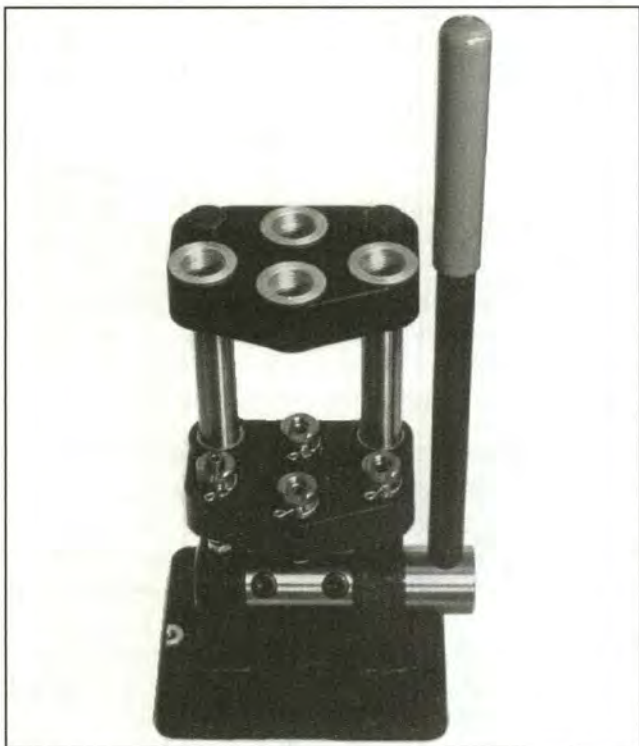

The H-frame press, as typified by the CH/4D No. 444, has many followers since it holds a full set of dies and powder measure. In this system, the "turret" is fixed, thus no rotation between steps is required. The case is simply moved from station to station.



The Dillon RL 1050 will load 1000 to 1200 rounds per hour. A progressive loader of this sort represents a sizable investment and is definitely not for beginners.

ment, precise measurement, and inspecting every step in production are your job, and if you do it well, the results will show in the finished product.

Progressive loaders are designed more for speed than precision. In the case of handgun ammunition where benchrest accuracy is not expected, they are the best investment for a shooter who really burns a lot of ammunition. These are also purchased by clubs, police departments and professional reloaders who sell their ammunition. While progressives churn out tremendous quantities of ammunition, they generally require a fairly complicated set-up period, and if there is a change of caliber of ammunition, this can mean a different set of feed tubes and plates as well as dies. Because they are complicated, progressives require more tinkering and cleaning to keep them running smoothly. Automation of the process means you depend on the machine to do it right every time. That doesn't always happen.

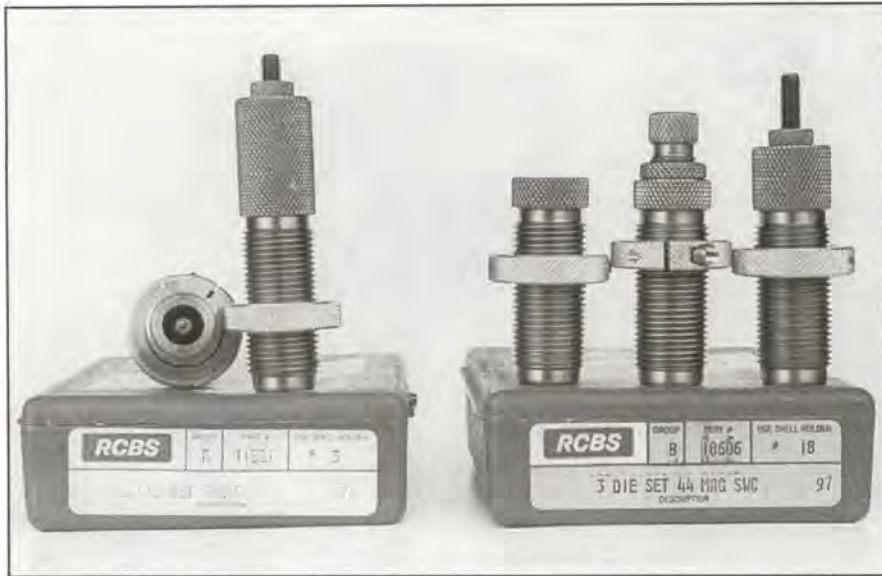

Reloading dies come in two basic formats—a two-die set for rifle cartridges and a three-die set for pistol and cast-bullet rifle loading.

Special precision dies feature micrometer adjustment and, in this example, spring-loaded sleeves for precise bullet alignment. This benchrest die set is from Forster.

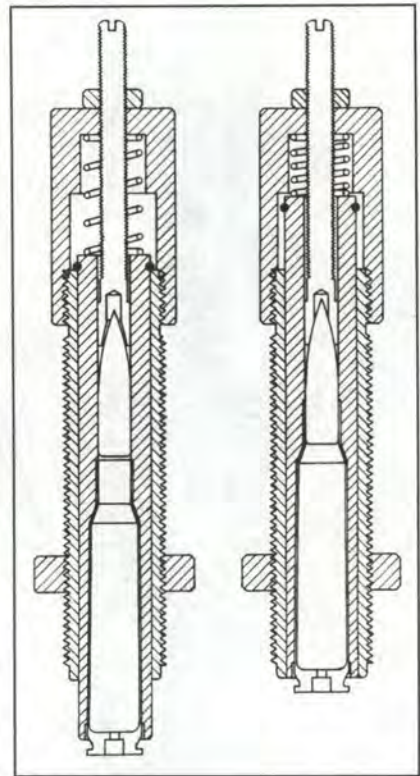

### Precision Versus Economy

As mentioned above, precision and economy lie mainly with the single-die and turret/H-frame (multi-station) machines. Progressives only pay when there is a demand for high-volume production of one caliber at a time. The price differential between the single-stage and turret/multi-station machines is close enough that it is probably worth the extra money to invest in the latter if you are going to do more than a very modest amount of reloading. They have the advantage of holding a full die set and a powder measure. This means the dies are seated and adjusted once, for the most part, unless you are reloading a number of calibers. The production edge will be noticed as the amount of ammunition you make increases. For a shooter reloading a single caliber—mainly for hunting—someone who does not do a lot of practice and may assemble no more than 200 to 2000 rounds a year—the best buy would be the simple, reliable O-or C-frame machine. It will do the job.

### Reloading Dies

Once a press is purchased, it must be equipped with one set of dies for each different cartridge you reload. For handgun ammunition, the first die decaps the cartridge and resizes it to unfired dimensions, the second expands the case mouth, and the third seats the bullet. Rifle dies do not expand the case mouth since this is not necessary for hard, jacketed bullets. Cast bullets, however, require this expansion to keep them from being accidentally cut by a sharp case mouth.

Dies come in grades from plain to fancy. Basic die sets

of steel will last for many years and many thousands of rounds of ammunition. Using tungsten carbide or titanium nitride dies requires little or no lubrication of the cases, which speeds the loading process a bit, and they last longer than steel. Forster, Redding and Jones offer micrometer-adjustable bullet seating dies, while Harrell's Precision makes a variable base for reforming benchrest cases to near chamber dimensions. Specialty dies of this sort cost more and are worth the price if you are into competition target shooting. There are special neck-sizing dies for use with bottleneck cases that will only be fired in one particular rifle, thus there is no need to put cases through the wear and tear of full-length resizing. There are custom dies for obsolete calibers and loading cartridges as large as 20mm. Nearly anything your heart desires will cheerfully be made up by the 4-D Custom Die Co. of Mount Vernon, Ohio.

### Primer Seaters and Shellholders

Primer seaters generally fit in the front bottom of the reloading press, and you will need one for large diameter primers and another for small primers. It's probably a good idea to buy both since a pair is generally quite inexpensive. Case or shellholders are needed to hold the case as it inserted into the die. One size does not fit all, but Lee and Lyman offer sets that cover most popular rifle and pistol cartridges.

A real headache is getting the primer crimp out of a military case. A number of die makers offer a useful die to remove this crimp with a stroke of the loading press handle. There is also a chamfering tool to do this, but some prefer a swager die.





The primer seater, as shown on this RCBS Rock Chucker, is usually included as part of the press, but if you get used equipment, be sure all parts are there.

### Sizer/Lubricators

The second large bench tool you will need is a sizer/lubricator if you are planning on shooting your own cast bullets. In addition to applying lubricant in the grooves of the bullet, the sizer rounds them out to a dimension determined by the sizing die. By the use of various dies, you can control bullet diameters to .001-inch.

### Small Bench Tools

These are either mounted on the bench or on the press, or are freestanding on the bench.

Powder scales are absolutely essential when working up loads, as well as for checking those that are measured with a hand dipper or metered by a powder measure. Basic balance scales will do an accurate job, but the speed advantage goes to the electronic models.

Powder measures are not an absolute necessity, but are invaluable when it comes time to get into production loading. They can be mounted on a loading press or a stand. The precision of the adjustment is not all that different. More expensive models adjust faster and a little more precisely, keep their accuracy more consistently, hold more powder and so on. The accuracy of powder-measure metering is mainly dependent on the consistency of the operator as he pulls and returns the handle.

Case trimmers are essential for keeping cartridge



Shellholders must be purchased to fit the cartridge you are reloading. Some accept more than one cartridge, and they can be had in sets.



Problems such as crimped-in primers and stuck cases, like this one with the head torn off, require special tools such as a stuck-case removal kit.

length consistent. Cases stretch on firing and in reloading dies, and must be trimmed back every so often. Hand-cranked models do the job, with a selection of collets and pilots available to handle most common calibers. Collets hold the case head, and pilots guide the case mouth straight against the cutter. Motorized models do the job more quickly.

### Hand Tools

Case deburring or chamfering tools come with a bench mount and, in the case of the Forster case trimmer, can be purchased as an add-on feature. They are also made in hand-held versions. These are necessary to take burrs off the outside of a case mouth that has been trimmed and to chamfer (bevel) the inside of the case mouth, removing burrs that will otherwise scratch and gall jacketed bullets.

A primer pocket cleaner can be simply a flat-blade screwdriver, inserted into the primer pocket and turned several times to get the fouling out. However, all the major (and some minor) tool makers have them, and they're not expensive. The two basic types are the scraper and brush styles, and both do good work. Getting the primer ash deposit out of the pocket is necessary or the fresh primer will not seat properly. The ash build-up will either result in a high primer or one that may give poor ignition, as the firing pin blow is cushioned and the vent blocked by ash.

A steel straightedge ruler will check that your primers are seated deeply enough.

Lyman, Redding, RCBS and others offer case-care kits containing primer pocket cleaners and an assortment of case brushes to remove interior fouling, a good investment if you are loading blackpowder or Pyrodex ammunition. If you want to automate things a bit, Lyman and RCBS have a number of options to do so.

Loading blocks are the best way to keep from double-charging your cases. They come in molded plastic from several manufacturers and cost very little. You can make your own by drilling holes in a flat piece of 1-inch plank and gluing on a flat bottom. A loading block is the best way to inspect your cases after they have been charged with powder, before you seat a bullet. Double charging is very easy to do, especially when using a powder measure. If you shoot one of these loads, your gun will never forgive you.

Powder funnels cost little, and their use is only way to avoid spilling powder when you are working up loads by weighing each one. A charge drawn from a powder measure and dumped into the pan of your scale for checking is the way to maintain accuracy in your measure. If everything is working as it should, the charge in the pan is then funneled into the case. Forster offers a funnel with a long drop tube for loading nearly compressed charges.

Micrometer/calipers are the best means of making all sorts of precision measurements, like case length, inside and



The ultimate in precision and speed is the RCBS PowderMaster electronic powder trickler, combined with their Powder-Pro electronic scale. This the only reliable device of this type the author has seen that allows the loader to program an exact charge and get it consistent; with accuracy to 1/10-grain.

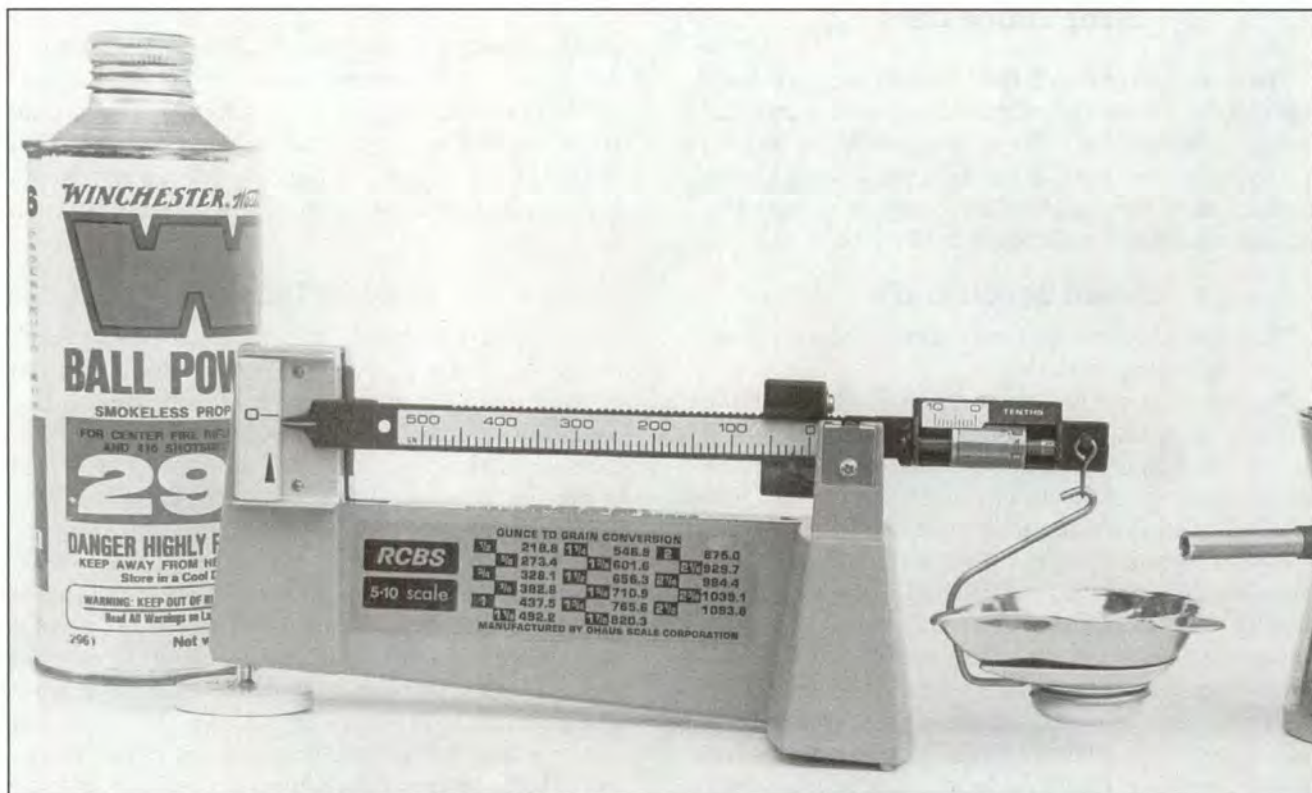

An accurate powder scale is an absolute must for working up loads. The beginner and expert should have and use this valuable piece of equipment.



A powder measure speeds production and can throw accurate loads. Precision, however, depends on the consistency of operation.

Cases stretch in firing and reloading, and every so often they will need to be trimmed to the proper length. A case trimmer requires various collets and pilots to trim accurately.



outside diameters, case neck wall thickness, checks for bullet roundness and diameter, case swelling, etc.

Bullet pullers are there for the same reason they put erasers on pencils. Everybody, sooner or later, puts together some loads that won't fly for one reason or another and need to be taken apart. The two basic types are the one that screws into the die hole on your press and the kinetic type, which looks like a hammer. The press-mounted type is easy to use, but can mar the bullets, making them unshootable. The kinetic model features a hollow plastic head into which the cartridge is fitted. A wad of cotton or

tissue can be used to cushion the bottom of the chamber where the bullet is caught. With this addition, even very soft lead-alloy bullets may be retrieved undamaged. These are very efficient and handy tools.

### Case Cleaning Equipment

Do shiny-bright cases shoot bullets straighter than tarnished ones? Case cleaning is something like car washing—you either believe in it or don't. The only real advantage of clean cases is that small cracks and flaws are more easily seen on shiny surfaces. If smokeless powder is used,

most cases stay pretty clean, unless they receive a lot of handling with sweaty fingers or fire a number of low-pressure loads that fail to expand the case fully, which coats it with soot. Most cases will shine up in the sizing process, unless you only neck-size. Polishing with a cloth before you put the finished cartridge into the box will generally keep them bright for a long time.

After much use and especially after using Pyrodex or blackpowder in them, brass cases will take on the look of an old penny. Since both blackpowder and Pyrodex leave corrosive deposits (sulfuric acid), cases should be washed out soon after shooting. There are two basic case-cleaning methods, chemical and mechanical. Chemical cleaning involves washing the cases in a bath of an acid-based cleaner. The cleaner is sold as a concentrate to be mixed with water in a plastic, glass or stainless steel container. The cases are given a wash, then thoroughly rinsed. If the mixture is too strong or the cases are left in too long, these cleaners will begin etching the metal. Tarnish and dirt are removed, but the cases are left a dull yellow color. A polish is achieved by some means of buffing. Liquid cleaners are effective and require no special equipment.

Mechanical polishers are motorized tumblers or vibrators with containers into which the cases are dumped, along with a cleaning media composed of ground walnut shells or ground corncobs. Liquid polish additives are also available to speed the process. The cases are tumbled or vibrated for an hour or more and come out with a high shine. They must

be separated from the cleaning media, and the media must be cleaned and replaced every so often.

## Shotshell Reloading

While shotshells can be reloaded with simple hand tools, and RCBS does offer a shotshell reloading die set for use in its O-frame presses, most shotshell reloading is done on press-type machines. They are similar to the turret, multi-station and semi-automated (progressive) loader designs used for metallic cartridges. Shotshells, obviously, do not require the precision alignment of bullet with case that is needed for metallic cartridges. Thus, with a decline in the need for high precision, good speed can be achieved. Precision is, of course, required in sizing, wad column seating and powder charging, although accuracy is a matter of pattern density. This not to say that one can take a cavalier attitude when loading shotshells. A shotgun can be blown up with an overload as easily as any other gun, and with similarly disastrous results.

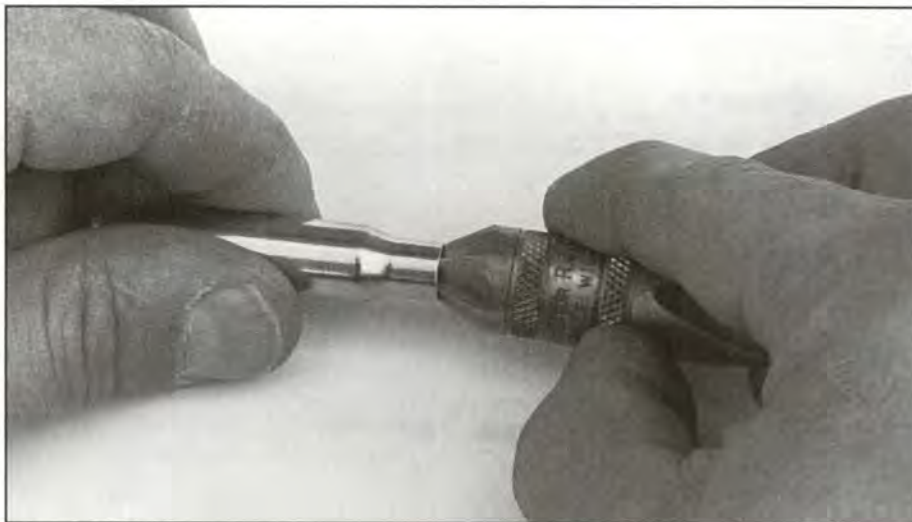

(Above and left) A deburring tool makes bullet seating easier and lessens damage to the bullet base.



Primer pocket cleaners scour burned residue from the primer pocket. This brush-type tool works quickly.

A micrometer and/or precision caliper capable of accurate measurement to .001-inch are necessary tools. Investing in good-quality equipment is worthwhile in the long run.

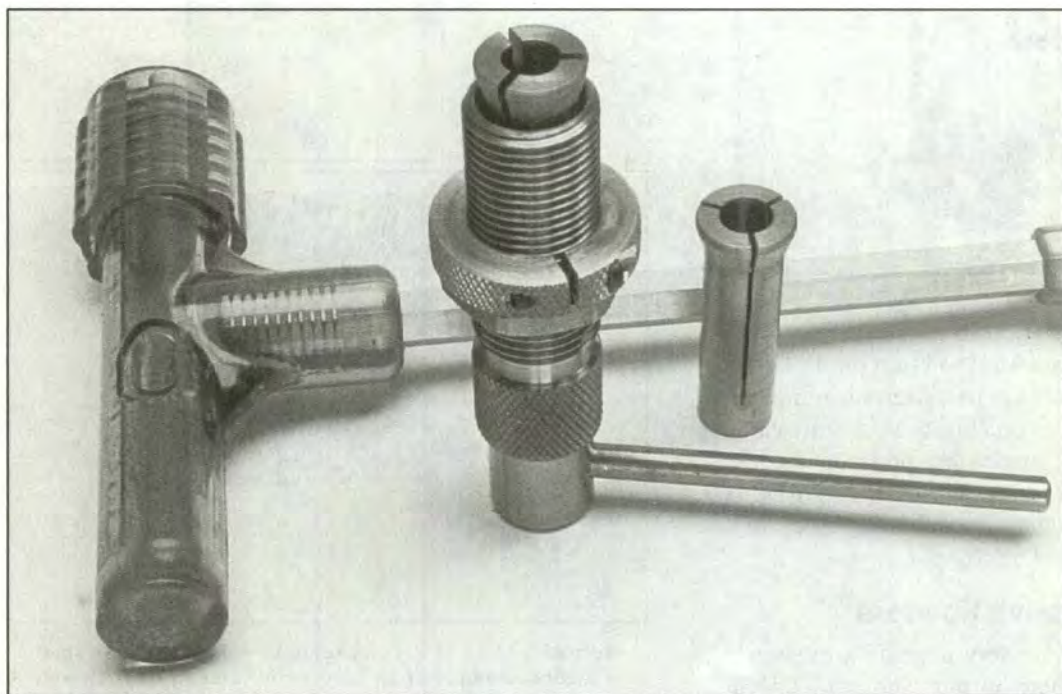
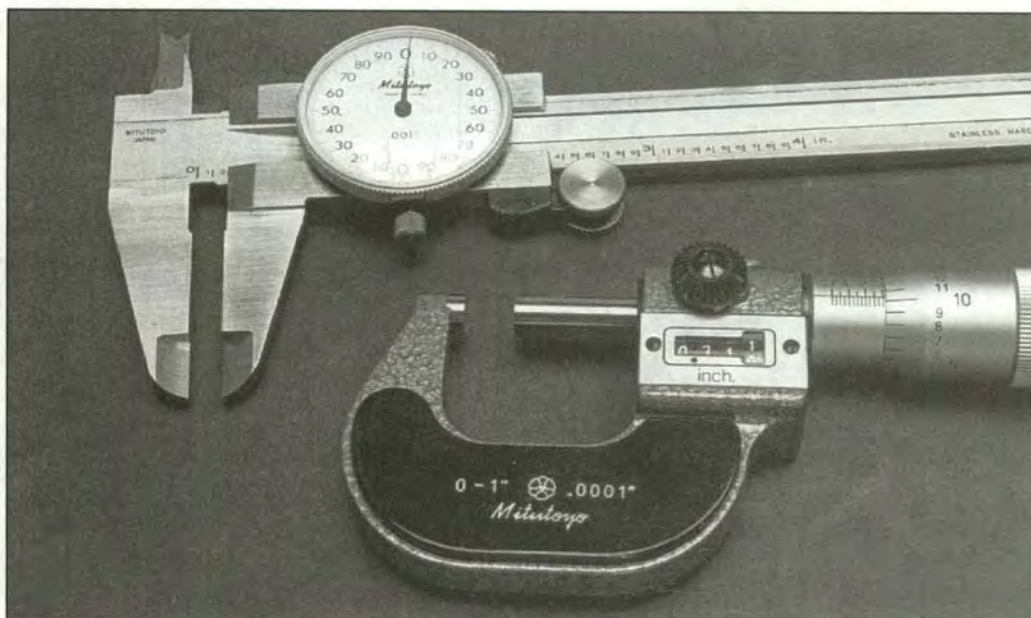

Bullet pullers come in two varieties: those that mount on the reloading press and those of the hammer-type kinetic variety (left). The latter is perhaps gentler on bullets, but requires more energy on the part of the user.

### Basic Equipment

If all you reload are shotshells, your needs for a bench and drawer storage are far less than for metallic cartridges. The stresses involved in sizing and reloading shotshells are less than those in making rifle cartridges. While a bench of some sort is needed, it does not have to be as large or robust. Shotshell presses do have to be firmly mounted. Overhead space is more of a consideration because many of these machines stand 2 feet high or more if you elect to attach hoppers to feed empty shells and/or wads.

Storage space is more of a concern if you are setting up for shotshell reloading, since the components are very bulky and you have more of them. Wads and shot are sold in bulk, which means finding a place to store 25-pound bags of shot

and big bags of plastic shot cups. Shotshells, loaded or empty, are bulky, requiring four to five times the space needed for an equivalent amount of handgun ammunition. Shelves or cupboards are a good idea to have close to your bench.

### Economy versus Speed

The same rule holds true for shotshell reloading as for rifle and pistol ammunition manufacture: Machines that turn out more ammunition faster cost more money. Because the process is somewhat simpler for loading shotshells, making ammunition goes faster. With most machines, all the necessary dies, the powder charger and the shot charger are contained in the press. With everything close together, and a need to do no more than pull an operating handle and



The Lee Load-All II (left) and MEC 600 Jr. Mark V are excellent machines for the casual shooter. The production rate is fast enough to satisfy most shooters unless they are heavily into competition trap or Skeet shooting.



move a shell from one station to the next, even a basic machine like the Lee Load-All II will turn out 100 rounds per hour. Lee offers update kits to convert older presses to the Load-All II and conversion kits to load other gauges. Hornady offers a similar single-stage press and a conversion to progressive loader status via a kit. The MEC 600 Jr. Mark V, while a single-stage machine, is set up for speed and will double the Lee's output.

### Progressive Loaders

Progressive machines are very popular with shotshell reloaders because of their output. Shotgun shooting, unlike rifle or handgun shooting, generally involves a lot of gun handling. Targets are close in the hunting field, but they're there only briefly. Practice for hunting, as well as just plain fun, is on the skeet or trap range, and this means a *lot* of shooting. Developing the reflexes to become a good scattergunner requires practice, which requires a larger consumption of ammunition than for most rifle or handgun work.

Progressive machines will turn out between 300 to 400 rounds per hour. Top-of-the-line progressives like the Hollywood Automatic weigh 100 pounds and can crank out an astonishing 1800 rounds per hour, if you have the muscle to keep pulling that long. For a lot less money, the MEC 8567 Grabber will turn out 500 finished shells an hour. These numbers are production time, of course,



Hornady's Stack 'N' Pack makes boxing shotshells easier and is a good example of an inexpensive accessory that's well worth the money.



Precision Reloading's D-Loader does for shotshells what a bullet puller does for metallic cartridges. The case, however, cannot be saved, only the contents.

and not counting the time spent loading hoppers, canisters and tubes with wads, primers, shot and powder. Progressive machines, because of their complexity, are more subject to problems than the simpler loaders. They require more cleaning and care as well, to keep them running smoothly.

### Accessories

Unlike rifle and pistol presses, where you must buy separate die sets, shotshell reloaders come equipped with a set to load the gauge you prefer. Extra sets, of course, may be purchased, but six sets would load everything from .410-bore to 10-gauge. A great many machines come with conversion kits to upgrade performance, handle more gauges or load steel shot, which has its own requirements. There are dies to do six-fold, eight-fold or roll crimps. Most of the accessories for shotshell reloading are, therefore, add-ons to the basic press.

There are, however, several separate items that are necessary and useful. The precision scale for weighing powder and, in this case, shot is a must to work up and check loads. The same dial or digital caliper is also invaluable for checking case lengths and diameters. MEC makes a very handy metal plate gauge, cut with a dozen holes. This ring gauge allows a quick check on the diameters of all the standard U.S.-made shotshells and is essentially a go/no-go gauge for each. Hornady's Stack 'N' Pack and MEC's E-Z Pack are nifty racks for packing shotshells into standard boxes. The answer to the bullet puller is the Precision Reloading D-Loader, which allows the reclamation of shot, powder primers and wads from bad reloads. It also trims 10- and 12-gauge TUFF-type wads to length. It is a cutting tool, however, and will not save the shell itself.

### Organization

Getting all your equipment organized is a key to success in reloading. Tools too close together or too far apart for convenient reach slow your work and wear out your temper. Here again, one of the best ways to get started is to see how other reloaders set things up. If possible, try their equipment to get a feel for the process. Smooth operation stems from having the right tools in the right place and

components where they can be easily handled and stored. The right way is the one that works best for you.

Generally speaking, sizer/lubricators are mounted on the front of the bench. They do not need to be particularly close to the loading press since bullet sizing and lubricating is generally done as an operation separate from the

actual loading process. By the same token, the case trimmer, if bench mounted, need not be near the press since this operation is generally done separately, prior to loading. The press is really the center of your operation and should have clear space around it to place boxes or stacks of primers, bullets, cases and cans of powder. You may want to try mounting tools with C-clamps to start, so a change in position to a final location and bolting down only has to be done once, as you develop a plan for working. A comfortable chair is a real asset since you will be spending many—hopefully happy and productive—hours there.

CARTRIDGE _____	Overall length _____
Case, make _____	Times reloaded _____
Primer, make, type _____	
Powder _____	Charge _____
Bullet, make, type, weight _____	
For gun _____	
Sight setting _____	Range Zero _____
Velocity, Chronographed _____ est _____	
Date Loaded _____	
Remarks _____	
_____	

A simple reloading data form can be created on a computer and reduced to stick-on labels for cartridge boxes, and/or kept in notebook form for ready reference. Accurate records are essential.

able chair is a real asset since you will be spending many—hopefully happy and productive—hours there.

### Record Keeping

The importance of record keeping cannot be overemphasized. Your load-data book of what you load and how it shoots will keep you up on what you have tried, how well it worked and, depending on your analysis and commentary, will serve as a guide to further experimentation. Without accurate records, you have to rely on that poorest of devices—memory. The type of data storage and method you choose is, again, what works best for you. A pocket tape recorder can be carried to the range, and notes and comments transcribed later. Some people prefer data forms because they require the least work.

Record keeping includes the box in which you keep your finished ammunition. Unmarked boxes equal “mystery” loads. When working up a load, you should mark the box by indicating primer type, primer make, powder type, charge, bullet weight, alloy, lubricant and exact size. You can write on the box or use stick-on notes. Less data may be needed once you have found a load you wish to produce on a regular basis. Here again though, care must be taken to mark *clearly* high-pressure “hot” loads if you have both strong- and weak-action guns of the same caliber.

You've made the decision to reload, you've collected all the necessary components, set up a safe workspace with the proper tools, and done the research. It's time to get started.

# Rifle Cartridge Reloading

## Case Inspection

Even new and once-fired cases should be checked over for defects. Any with splits or serious defects in the case mouth that are not ironed out in the resizing die should be discarded. Cases should be segregated by maker as determined by the head-stamp. Even though they are the same caliber, cases of different manufacture have slight differences in wall thickness and vent (flash hole) size. Mixing brands can alter velocities and pressures, and open up group size.

## Full-Length Resizing

This step is just as necessary for new cases as for fired ones. If these will later be used in only one rifle, further resizing can be limited to neck-sizing only, unless heavy loads are used. Before any operation can take place on the reloading press, the die must first be adjusted to resize the case properly. For full-length resizing, with the shellholder snapped into the ram, lower the



Empty cases should go back in the original box after firing so various brands and calibers don't get mixed.



press handle completely; screw the sizer die into the press until the bottom of the die hits the shellholder. Now, raise the press handle enough so you can screw the die down about 1/8-turn more, then set the large lock ring/nut. Make further adjustments so the bottom of the expander ball is 3/16-inch up inside the die, and the decapping pin should extend 1/8-inch below the mouth of the die, which is just enough to knock out the spent primer. The best bet is to follow the instructions that come with the die set or take the time to really read a loading manual, which usually will include such instruction.

To resize a case, it must first be given a thin coating of case lubricant to allow it to work easily in the sizing die. Sizing lubricant is a special oil or grease made for this purpose.

Regular gun oil will not work. It is best applied by saturating a case lube pad with lubricant, then rolling the case over it, lightly coating the outside of the case. Too much lubricant on the outside of the case will cause dents in the walls which will flatten out on firing, but will stress the metal. Several brands of spray lube also are available, and can speed up the lubing process. On bottleneck cases, the inside on the neck should be cleaned with a brush and lubricated with a dry, case neck lubricant. Oil can run into the powder and ruin it. Neck lubricating keeps the neck from stretching unduly in the die. A light coating of lubricant is all that is needed. To begin resizing, the prepared case is inserted in the shellholder, and the press handle is pulled, to run the case completely into the die.

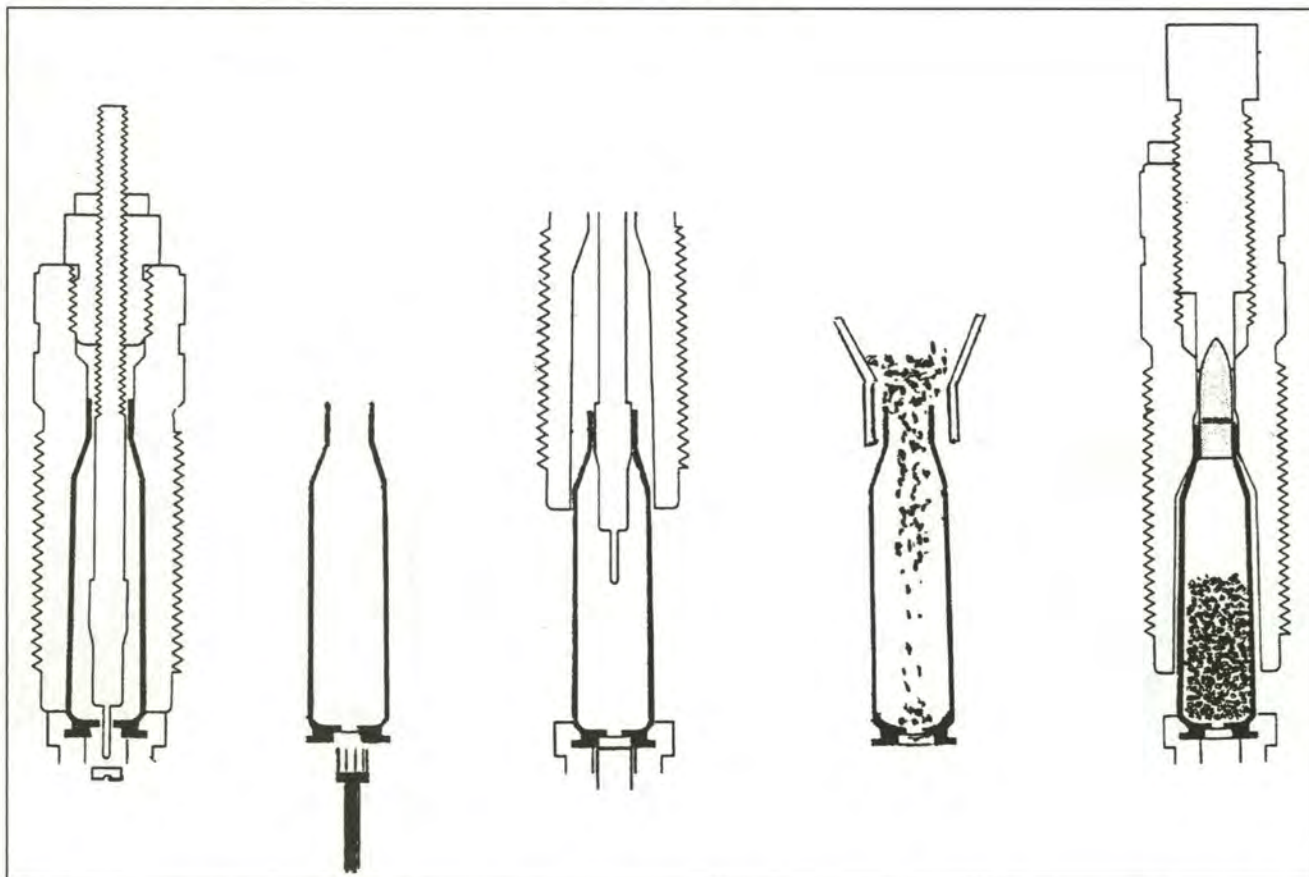

The basic steps in rifle reloading include resizing and decapping, primer pocket cleaning, inside neck expanding (done in the upstroke of the decapping process), priming, powder charging and bullet seating.

## Decapping

The die should be adjusted so the decapping pin just removes the old primer, which will drop out at the end of the up-stroke. The resizing/decapping process should require a medium amount of force. If a lot of force is required to get the case in the die, you have not used enough lubricant. Back it out. If you persist, there's a good chance the case will seize in the die. If that happens, you'll need to send the die back to the maker to remove the case or buy a tool to do the job yourself.

## Inside Neck Expanding

The decapping pin is mounted in a rod with an expander ball on it that stretches the case mouth large enough to accept a new bullet. This operation is completed on the up, or removal, stroke of the press operating handle.

## Inspection, Gauging and Trimming

The case is now removed from the shellholder for inspection. The case mouth should be smooth and perfectly round. "Trim to length," say the books because a too-long case will enter the throat of the barrel and raise pressures as the bullet is pinched in the case. A quick check with a case length gauge or measurement with your caliper tells you if the case is too long. If the case is too long, it goes in the trimmer to cut the case to exact length. After trimming, the burr on the outside of the mouth is removed and the inside is chamfered slightly to give the bullet a smooth start. Do not cut a knife's edge on the case mouth. This trimming/chamfering operation only needs to be done when cases get too long.

## Priming

If the case is a fired one, the primer pocket should be scraped free of ash with a screwdriver or cleaning tool. The case is now ready for priming. Place a primer in the priming punch sleeve. This comes up, in most cases, through the center of the shellholder. Place the case in the shellholder and pull the operating handle to lower the case onto the primer

punch. This will seat the primer in the case. Enough force should be applied to seat the primer fully, but not crush or flatten it. Difficulty in seating may be experienced if you are using crimped military brass. If so, this crimp must be removed before proceeding.

After priming, the case should be checked to see that the primer is fully in the pocket. This is done by placing a steel straightedge ruler across the case while holding it to the light to see if the primer sticks up above the case head. It should not. A high primer gives poor ignition—or may not fire at all—as the firing pin simply drives it into the pocket. The primed, inspected case now goes into the loading block.

## Case Mouth Expansion

This step applies only to straight-walled cases loaded with cast, lead-alloy bullets and uses the second die in a three-die rifle set. Three-die sets do not expand the case mouth in the decapping stage. The case is placed in the shellholder and run into this die, which has a stepped or tapered expander plug to open or bell the case mouth for insertion of a soft, cast bullet. This mouth expansion is done before powder charging.

## Powder Charging

The case is now ready for charging. When working up a load, always start with the beginning load listed in the data manuals. Increases in powder charges should be made by no more than a half-grain (.5) at a time. Load and test fire at least ten test cartridges before going to a heavier charge. Weigh powder charges precisely on a powder scale. Using a powder measure, dispense a slightly low charge into the scale pan. A powder trickler will add minute amounts to bring the charge up to the desired weight. The scale should be properly set up and checked for adjustment according to the maker's instructions.

Once the charge is weighed, the powder funnel goes on the case and the powder is poured in, with no spills, of course. The funnel is moved from case to case until every one in



Too much lubricant will make dents in cases. These will flatten out on firing, but this works and weakens the brass.



Case length should be checked after sizing and neck expanding.

Powder dippers can be purchased or homemade to pick up a fairly accurate charge of a particular type of powder. All dipped loads should be checked regularly on a powder scale.

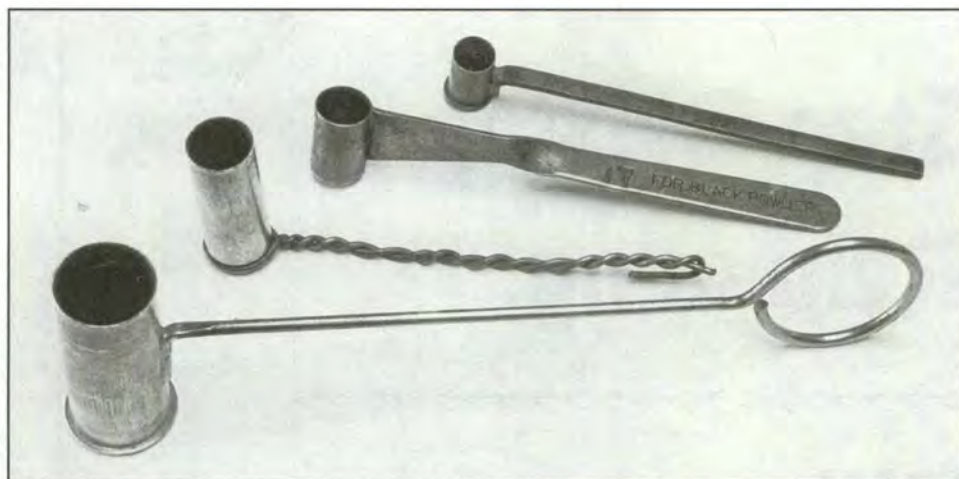

Powder measures can be fairly accurate if operated carefully, but the loads should be weighed often, especially when making maximum loads or loading with fast-burning powders.



the loading block is charged. Make it a habit to check the powder level in *all* the cases in the loading block, examining them under good light, even though you are sure you did not double-charge any of them. If the powder level in any case looks suspiciously high, weigh it again.

### Using A Powder Measure

The precision of mechanical powder measures depends to a great degree on the *consistency* of pulling and returning the operating handle. Use the same motion time after time.



The reloader's powder funnel is especially designed to fit over the case mouth and deliver powder without spills. One size fits nearly all commonly reloaded cases.

After a powder measure is adjusted, check its accuracy, and yours, by dropping every fifth load into the scale pan for weighing. Accurate loads are within a tolerance of  $\pm 1/10$ -grain (.1). Always visually check cases loaded with a powder measure in the loading block. It is very easy to pull the handle twice on the same case.

### Bullet Seating

This is the final step in the loading operation. A case is placed in the shellholder, a bullet is placed in the case mouth as straight as possible, and the case is gently levered up into the bullet-seating die. Proper die adjustment is necessary so you don't exceed the maximum overall length of the cartridge as listed in the loading manual. An overly long cartridge will press the bullet into the rifling and raise pressures. The easiest way to avoid this problem is to make up a dummy cartridge. After the die is screwed into the press, adjust it so the case enters freely its full length. Gradually ease the dummy cartridge into the die and check to see it

*(Text continued on page 111)*

# Step-By-Step Reloading

## Rifle Cartridges

(Photos courtesy of RCBS/ATK)

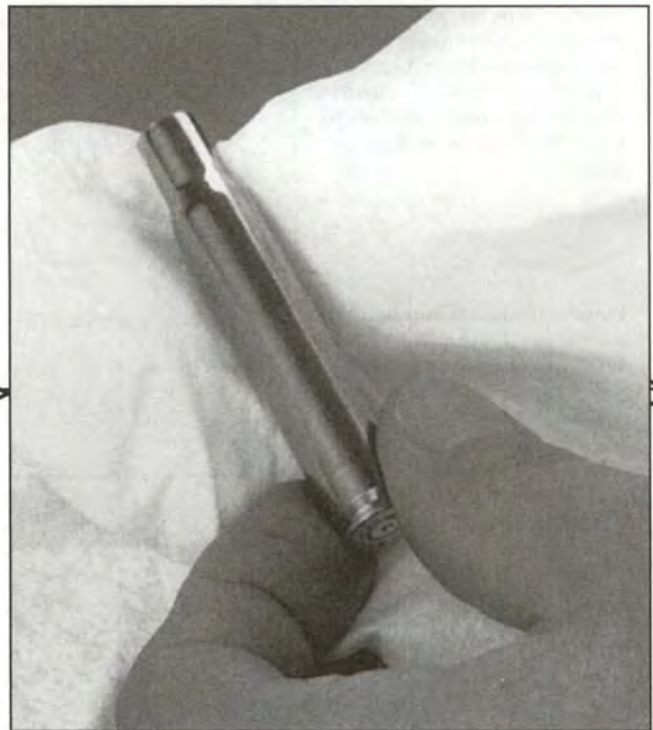

**Step 1 - Clean and Inspect:** It's always a good idea to wipe each case clean to prevent dirt from scratching the case and resizing die. Look for split necks, case cracks and anything else that would compromise safety. Destroy any defective cases by crushing, and then throw them away.

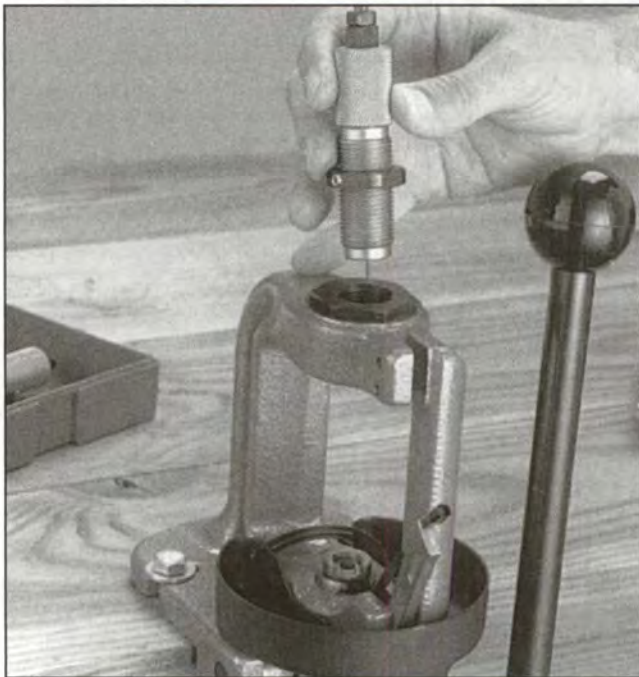

**Step 4 - Adjusting the Sizer Die:** With a shellholder installed in the ram, and the ram all the way up, thread the sizer die into the press until it touches the shellholder. Raise the press handle a little and turn the die in another 1/8- to 1/4-turn, then set the die lock ring.



**Step 5 - Case Resizing:** Insert an empty case into the shellholder and gently lower the press handle all the way to the bottom, running the case into the sizing die. Doing so will resize the case to factory dimensions and knock out the fired primer. Raising the press handle will lower the case and expand the case mouth to the proper dimension to hold the new bullet.



**Step 2 - Lubricate the Cases:** To prevent the case from sticking in the sizing die, it must be lubricated only with sizing die lube. With a bit of lube on the pad, roll a number of cases over it a few times to lightly coat the case body.

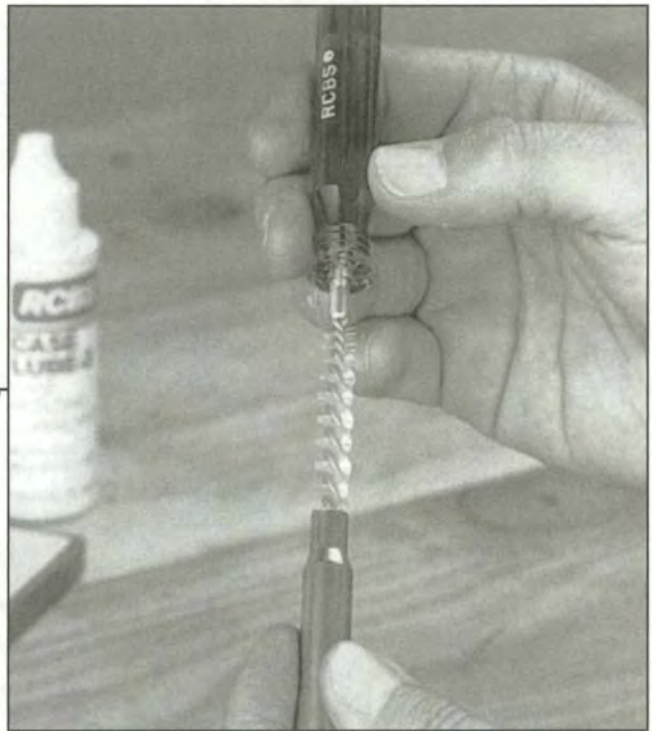

**Step 3 - Case Neck Lubrication:** Use a case neck brush to clean and lubricate the inside of the case neck. This will reduce resizing effort and neck stretching. Only a small amount of lube should be applied to the brush.

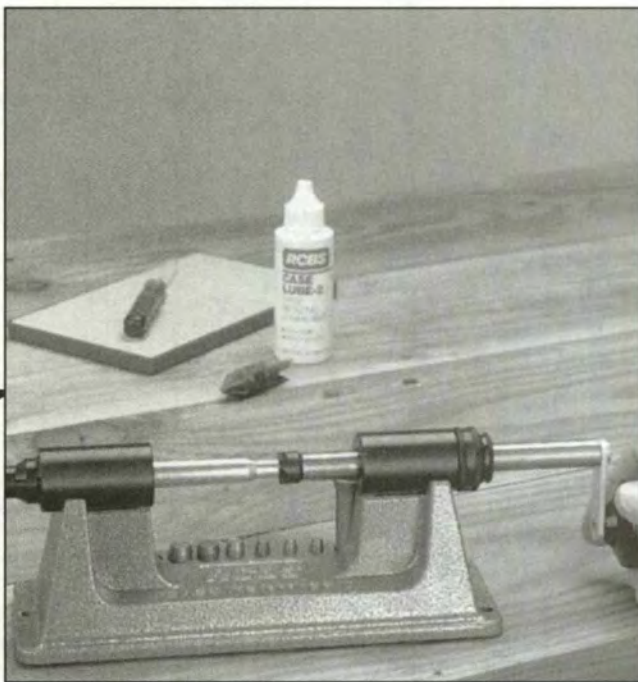

**Step 6 - Case Trimming:** Cartridge cases tend to stretch after a few firings, so they must be trimmed back to allow proper chambering and for safety reasons. Reloading data manuals will give the proper trim and maximum case lengths.

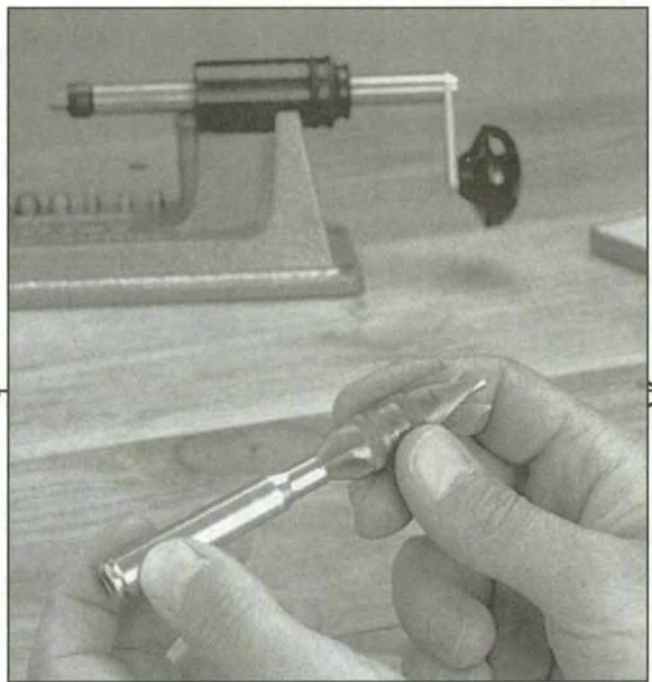

**Step 7 - Chamfer and Deburr:** After trimming, the case mouth will have a slight burr, and the sharp edge of the mouth needs to be smoothed. A twist of a simple hand tool removes the burr with one end and chamfers the case mouth with the other end for easy insertion of the new bullet.

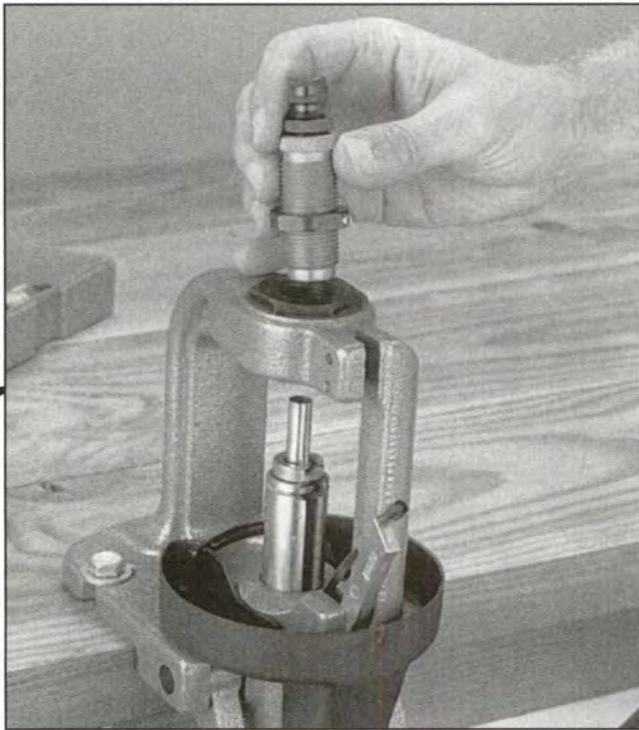

**Step 8 - Case Mouth Expansion:** This step applies only to straight-wall cases and is done in a separate step. Install the expander die in the press, insert a case in the shellholder and run the case up into the die. This die should be adjusted so the case mouth is belled or flared just enough to accept a new bullet.

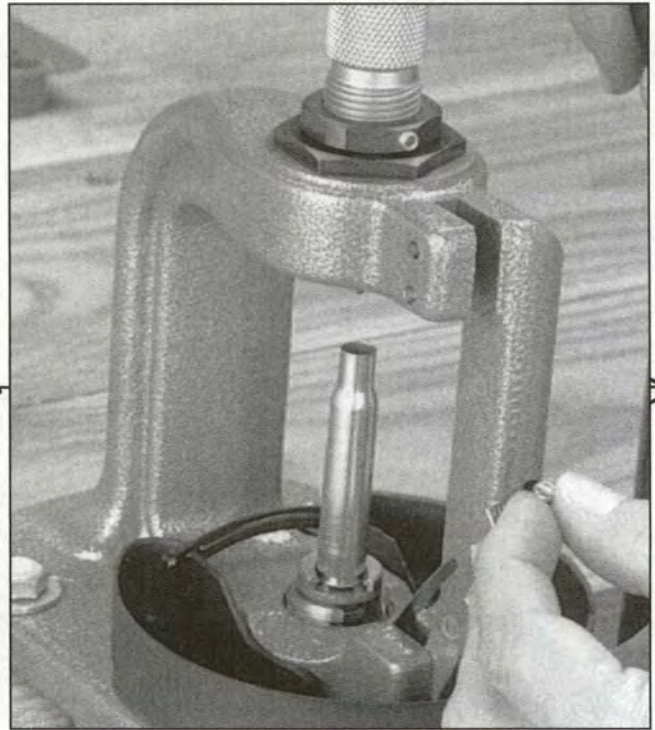

**Step 9 - Priming (A):** Place a fresh primer, anvil side up, into the cup of the primer arm and insert a case into the shellholder.

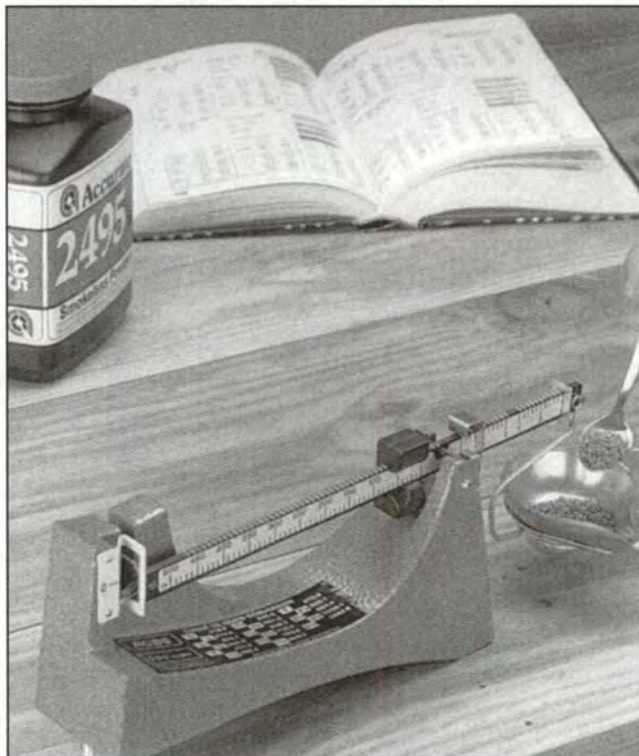

**Step 12 - Powder Charging (A):** Look up the load in your loading manual to see exactly how much and what powder you need. It's a good idea to weigh each charge for safety and consistency.

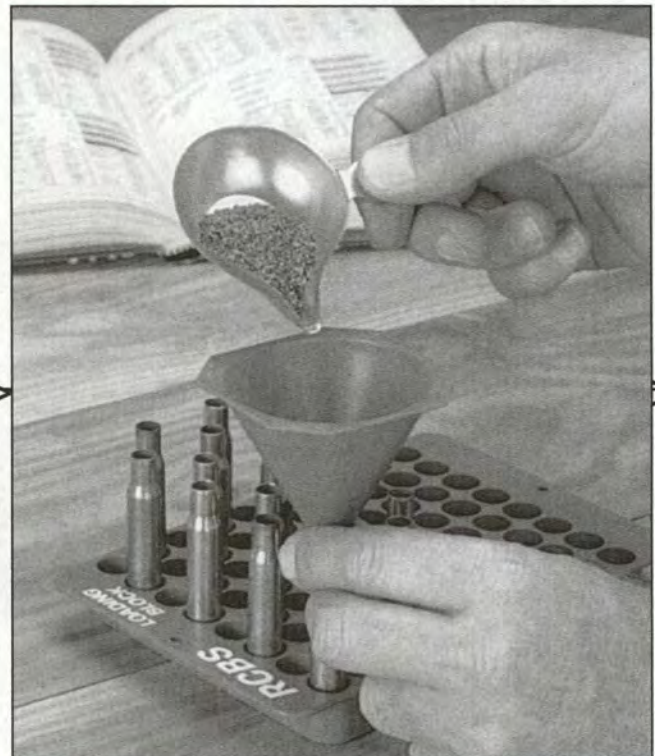

**Step 13 - Powder Charging (B):** After weighing the charge, use a funnel to pour it into the case without spilling.



**Step 10 - Priming (B):** Lower the press handle and push the primer arm all the way into the slot in the ram.



**Step 11 - Priming (C):** Gently and slowly raise the press handle. This lowers the case onto the priming arm, seating the fresh primer. Check each case to be sure the primer is fully seated.



**Step 14 - Powder Charging (C):** Another method of charging is to use the powder measure. It dispenses a precise, uniform charge with each crank of the handle, thereby speeding up the process. Use the reloading scale to adjust the powder measure until it throws several identical charges. Then, weigh about every ten charges to recheck the weight.



**Step 15 - Bullet Seating (A):** Thread the seater die into the press a few turns. With a case in the shellholder, lower the press handle, running the case all the way up into the die. Turn the die further in until it stops. While using the headstamp on top of the die as a reference, back the die out one full turn and lock it in place with the lock ring.

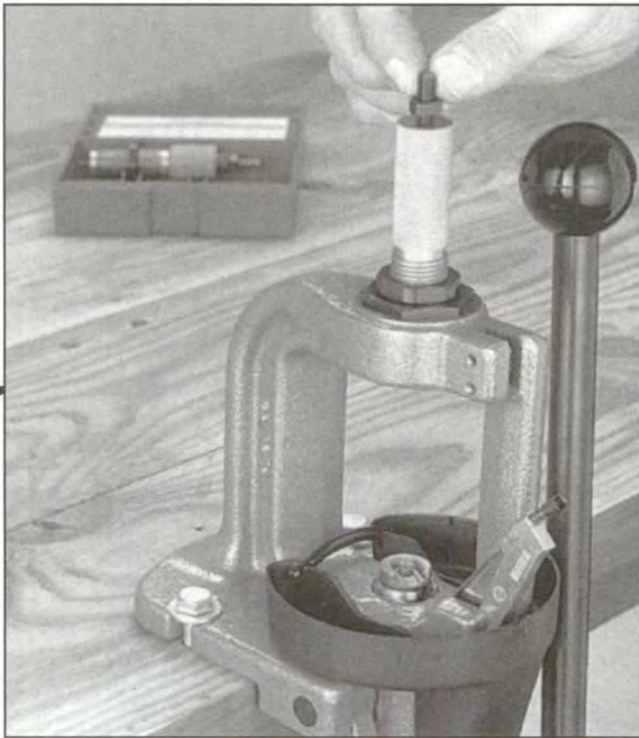

**Step 16 - Bullet Seating (B):** Now, unscrew the seater plug enough to keep the bullet from being seated too deeply.

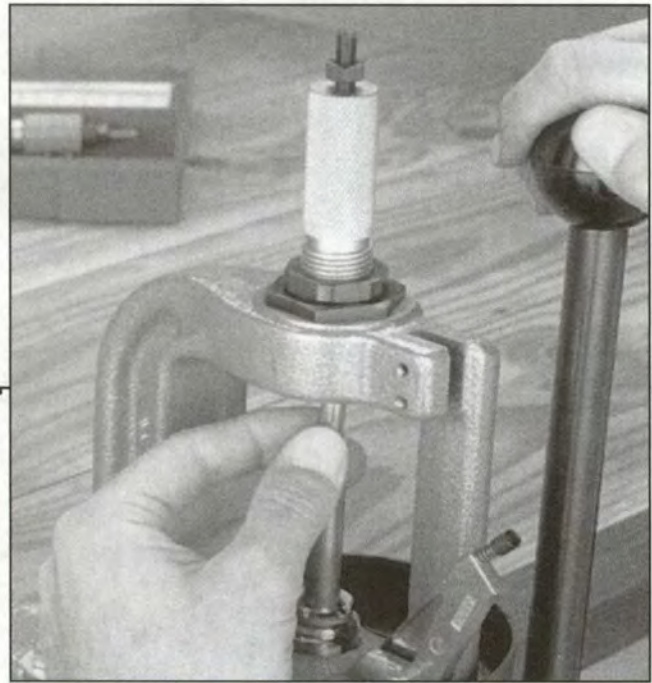

**Step 17 - Bullet Seating (C):** With the handle up, insert a primed and charged case in the shellholder, and hold a bullet over the case mouth with one hand while you lower the press handle with the other, easing the bullet and case up into the die. This will seat the bullet. Measure the loaded round to see if the bullet is seated deeply enough.



**Step 18 - Bullet Seating (D):** If the bullet needs to be seated deeper into the case, turn the seater plug down a little and run the case back up into the die. Make small adjustments and keep trying and measuring until you get the proper cartridge overall length. Once the proper setting is reached, tighten the seater plug lock ring.



**Step 19 - The Loaded Round:** After wiping off any sizing lube, the first loaded cartridge is ready to be fired.



(Text continued from page 105)

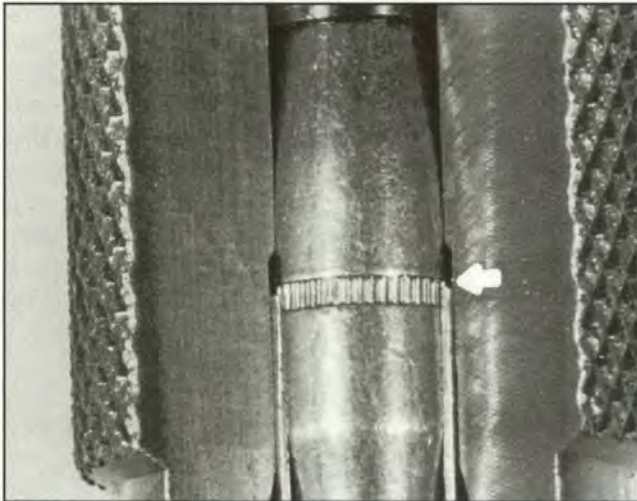

Seating dies have a crimping shoulder in them to crimp some hunting bullets. Never crimp bullets that do not have a crimping cannelure in them.

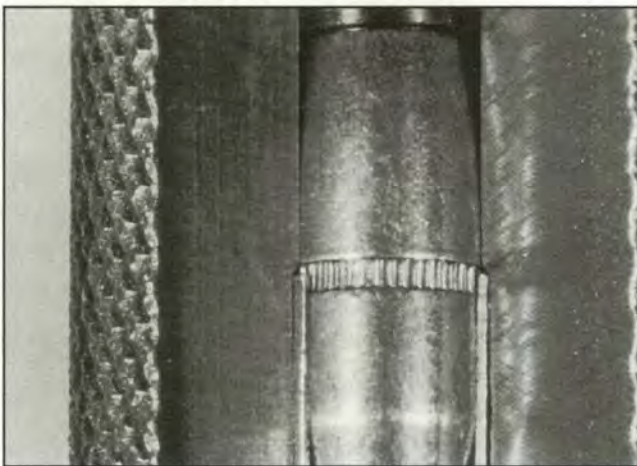

does not pass the crimping shoulder, which turns over the case mouth. The next adjustment is to the stem of the bullet seater, which gradually drives the bullet deeper into the case. When the correct overall length is reached, tighten the seater adjustment. Keep the dummy for easy readjustment after loading longer or shorter bullets. You may want to make a dummy for every different-length bullet you load to facilitate easy readjustment. Once the die is adjusted, bullet seating is simply a matter of repetition.

Most dies have a built-in crimping shoulder to turn the case mouth over into a cannelure (groove) in the bullet. This is necessary for high-powered ammunition, particularly if it is jarred by recoil or while being fed through the magazine. Crimping keeps the bullets from being forced back into the case under such circumstances. Military ammunition that will be fed through autoloaders and machineguns is always crimped, as is much commercial ammunition. Crimping degrades accuracy and should never be attempted on bullets that do not have a crimping cannelure in them. Hunting ammunition used in tubular magazines may have to be crimped.

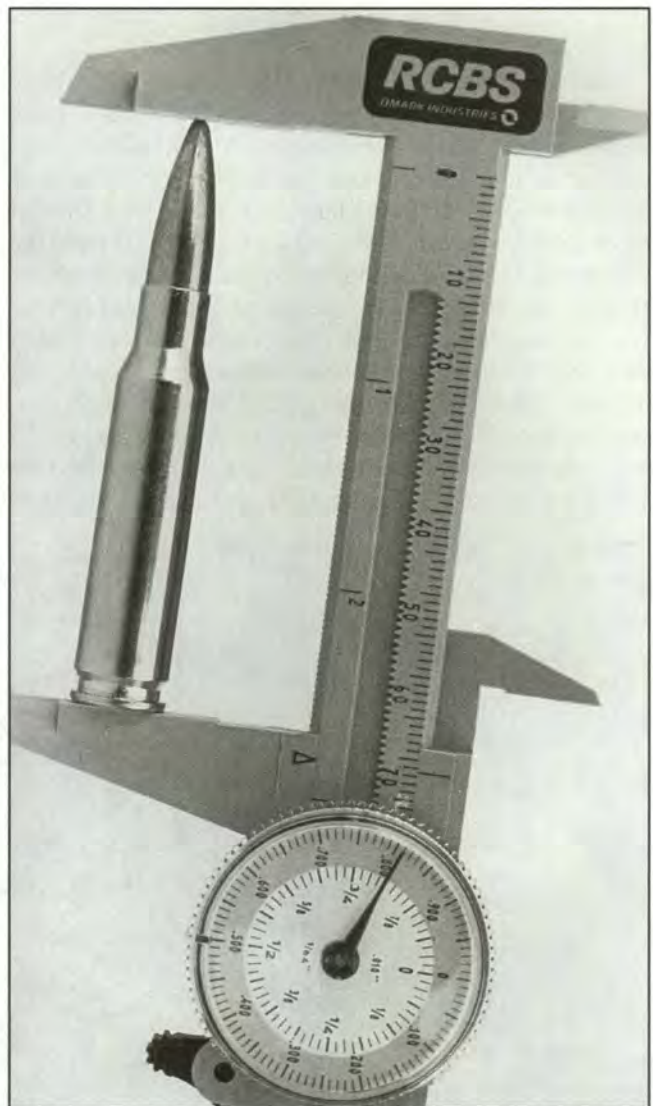

Finished cartridges should be checked to see they do not exceed overall length. If they do, the seater stem in the die can be adjusted to seat the bullets deeper.

Easy does it is the rule for all steps. Ramming and jerking leads to damaged cases, mashed bullets, flattened primers and broken decapping pins.

The final step is to wipe off any case lubricant that may be on the case and inspect the finished cartridge with a final check for overall length. Oil left on cases will cause excessive backthrust and batter your gun. If all dies are properly adjusted and firmly in place, there should be no difference from one cartridge to the next. Place the loaded rounds in a cartridge box and mark it accordingly.

Cleaning the loading area is always a good idea. Powder should always be returned to the original container, especially from the powder measure. Powder in open containers will lose volatiles and absorb moisture. Primers can absorb moisture, and magnum and standard primers can be confused if not put back in their respective containers. Most of all, there is always the chance of confusion regarding what powder you were using when you start to work the next time.

## Selecting A Load

Many people start with factory duplication loads, which, if you have already been shooting them, is a convenient place to start without varying any component. Generally, though, the best accuracy in your rifle will be something you work up on your own. This may take some doing, even though many loading manuals list "accuracy loads." If you read the fine print you will see this applies to one particular test rifle. If yours is a different make, this one may not shoot best for you, but it is perhaps the best powder/bullet combination to start with. Loading data is presented as starting loads and maximum loads with a middle ground in between. It is generally in this middle ground where the most accurate loading will be found. Rarely is the hottest, highest-pressure load the straightest shooter. Maximum loads, especially with jacket-

These offer good, cheap recreation and training without the expense, wear, noise and recoil of full-bore loads. They can be used for small game and varmint hunting at distances less than 100 yards with reasonable accuracy. Varmint loads with light bullets are practical in many 30-caliber rifles that will produce good accuracy and flat trajectory. Hunting loads are the most common for the 30s, unless you have a match rifle. For a hunting rifle, used primarily for hunting as opposed to competition, you would do best to work up the most accurate load you can from the selection of hunting bullets available.

## Working Up A Load

Working up a load means not merely careful loading of ammunition, but testing it and keeping records of the

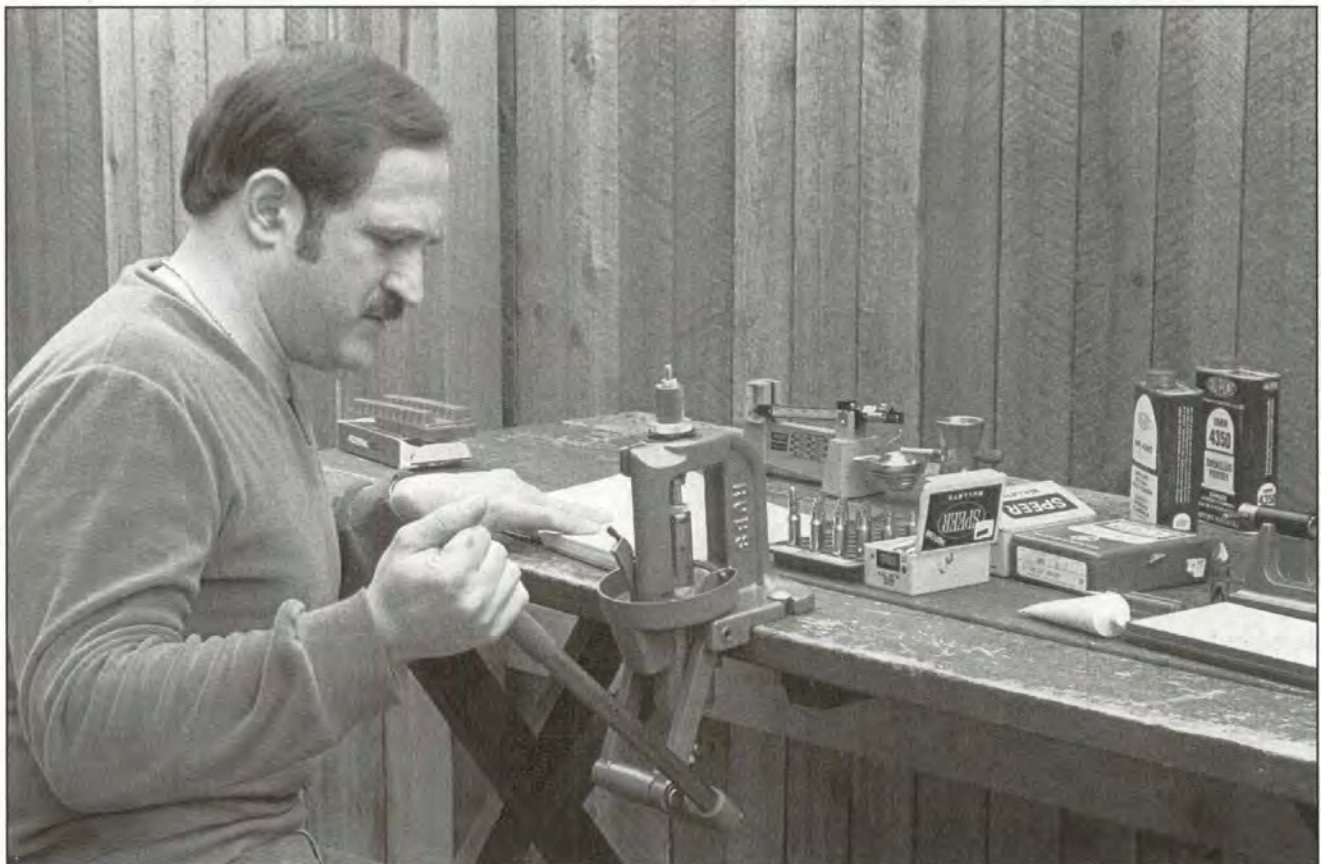

**Loads should be selected from a loading manual to reflect the type of shooting you want to do. Don't experiment unless you know what you are doing.**

ed bullets, shorten both case and barrel life. By working for accuracy, you start to get a clear idea of just how well your rifle will shoot. With this as a starting point, you then have a standard by which other loads can be judged.

For the most part, you will probably not have need for more than three or four different loadings, if that many. For 30-caliber rifles and up, about three different loadings will do for most of the shooting you'll be doing. On the bottom end are short-range practice loads. These are usually cast bullets driven at modest velocities of around 1200-1500 fps.

results. It also involves case inspection, looking for any signs of excessive headspace or pressures. You can use a simple notebook for records, listing loads under the name of the rifle and its caliber. Individual loads are listed under the bullet, indicating whether it is cast or jacketed, the weight, diameter and lubrication type. Next, the powder type and charge are shown. Following this is a notation on the make of case and primer type. Finally, there's a section for remarks. This includes a summary of the performance of this particular load, especially its accuracy. Ten-shot groups



The Marlin Camp Carbine in 9mm or 45 ACP is a fairly typical blowback autoloading rifle. There are a growing number of pistol-caliber carbines on the market, intended for home-defense, small game hunting and plinking.



The Ruger Mini-14 is a popular gas-operated autoloader with both civilians and law enforcement agencies.

are the accuracy test standard, although it has been demonstrated that seven-shot groups work just as well. Other remarks include the test range conditions like temperature, wind direction and velocity, and light conditions. Also noted are any indications of pressure problems. These are underlined as a warning for future reference.

### Loading for Autoloaders

Since WWII, autoloaders in all calibers and types have become very popular, owing mainly to the changeover by nearly all of the world's governments to this type of rifle for their respective militaries. While all autoloaders rely on the force of the explosion in the cartridge to function the action, there are a number of differences in the ways various actions operate, and these features have a marked effect on how ammunition must be reloaded for them.

There are three basic types of autoloading actions: straight blowback (with a variant known as delayed blowback), recoil-operated and gas-operated.

Blowback actions are the oldest design, and most simple. They function by having the bolt held in contact with the barrel by a spring, thus the two are not locked together. When the gun fires, the bullet is driven down the barrel while the case is driven against the bolt face. The weight of the bolt and force of the recoil springs, and the internal pressure swelling the case against the chamber wall, keep the case from moving backward until the bullet has exited the muzzle. Somewhere around this point, as chamber pressure begins to drop, the case begins to be blown back against the bolt; the inertial force given the bolt causes it to move rearward, cocking the rifle and ejecting the fired case. Tension in the compressed recoil spring sends the bolt forward, stripping a fresh cartridge from the magazine and chambering it. This system works well with low-powered pistol-type cartridges and is used in all 22 Long Rifle and 22 WMR rifles. It was used in only a relatively few centerfire rifles, such as the obsolete Winchester 05, 07 and 10 rifles, and the current Marlin and other carbines in 9mm and 45 ACP. The system is limited to straight-walled cases because a bottleneck case would likely have its neck pulled off or have gas come rushing around it as soon as the pressure seal was broken.

Because of the necessity of equaling the forces of the forward moving bullet with the proper amount of bolt weight and spring pressure, limitations of the system are obvious. To fire a cartridge the equivalent of the 30-06, such a system would need a bolt weighing several pounds and a very robust recoil spring. Thus, blowback autoloaders are limited to cartridges developing little better than handgun velocities and pressures.

Not surprisingly, reloads for such guns must be kept very close to factory specifications. Lower-pressure loads will not function the action, and high-pressure loads, even though the barrels can handle them, increase the velocity of the recoiling parts, battering them and causing serious damage to the rifle. Cast-bullet loads, both plain and gas-checked, work well if they are heavily crimped to provide proper burning of the powder. Slow-burning powders generally do not perform well in these rifles as they do not generate pressure fast enough to make the action function reliably.

Recoil-operated actions represent an improvement over the blowback in terms of the type and pressure of cartridge they can handle. In this system, the recoil of the rifle drives the operation. Recoil-operated systems keep the bolt and barrel locked together through part of the firing cycle. As the bullet travels forward, the barrel and bolt recoil as a unit. At about the midpoint of the operation, after the bullet has exited the barrel, the bolt unlocks from the barrel and continues traveling backward, ejecting the empty case and cocking the hammer. The bolt then strips a fresh round from the magazine, chambering it as the bolt comes forward. This system was used in the Remington Model 8 in 25, 30, 32 and 35 Remington calibers, and in the Johnson military and sporting autoloaders in 30-06. The downside of this system is the amount of recoil experienced by the shooter, which can be considerable.

Both blowback and recoil-operated autoloaders have fairly generous chambers and require full-length case resizing. Not too surprisingly, they are also rather rough on cases. Here again, the best functioning is with loadings close to factory specifications. The battering of internal parts will result from loads generating high pressures and high velocities. The best way to work up handloads for these two actions is

to do so slowly, checking recoiling parts for any evidence of battering. The best loads are ones that will reliably cycle the action and no more.

Gas-operated rifles are by far the best, and most high-powered rifles made today use this system. The gas-operated system features a locked bolt and non-moving barrel, much like the accurate and reliable bolt action. They can thus fire very powerful cartridges. At some point on the barrel, forward of the chamber, there's a small hole in the barrel that taps off a small amount of gas after the bullet passes that point. The gas is trapped in a small cylinder with a piston, much like that in an engine. The piston drives a rod, which operates a camming lock on the bolt, which opens it after the bullet has exited the barrel. In some variants, the gas is directed to the surface of the cam lock to unlock the bolt. As the bolt is driven back, the case is ejected and the hammer or striker is cocked, and a spring drives the bolt forward to strip a fresh round from the magazine and chamber it. Today's high-powered autoloaders are gas-operated. The advantages are a minimum of moving parts and an action that is comparatively gentle on cases. Felt recoil is also very manageable.

The placement of the gas port is critical to reliable functioning because the amount and pressure of gas must be enough to operate the rifle, but not enough to cause damage through battering. Needless to say, the amount and type of powder used is also critical to this system's functioning. Gas-operated autoloaders are, therefore, ammunition-sensitive and will work best with loadings duplicating factory or original military specifications. Cast bullets, generally, do

not work well in gas-operated guns. Fast-burning powders, such as IMR-4227, are about the only ones that will operate these actions reliably with cast bullets. Any cast bullets used in autoloading rifles should be of hard alloy, since soft bullets are often nicked and dented as they pass through the magazine and into the chamber. They are slammed up feed ramps, which will often cause them to catch and stick on something and jam the action. Because of the generous chamber proportions required for reliable functioning, cases fired in autoloaders almost always have to be full-length resized.

Ball powders tend to leave more fouling than some of the cleaner burning flake powders. The performance of ball powders in terms of reliable functioning is good, *so long as the gas port, piston and/or cam face are kept clean*. For best functioning, the powders used in reloading should be close to those used in factory loadings. Cleaning of the gas system is necessary for reliable functioning.

Reduced loads will not work reliably in any autoloader, with cartridges often getting jammed on the way out and chewed up in the process. Therefore, the range of loading options for autoloaders of any stripe is rather limited. There will usually be only a relatively few loadings that will produce good accuracy and reliable functioning. Ammunition prepared for autoloaders should be given extra care to see that all tolerances are kept close to factory specifications. Exceeding overall length will jam rifles. Cases too short and bullets seated too deeply can have the same effect. In short, ammunition preparation for successful shooting of these guns requires extra care for best results.

**Testing ammunition should be done with a solid rest, firing at a known distance to determine accuracy.**



## Testing Ammunition

Accuracy is, or should be, your first concern. An accuracy test can consist of nothing more than plinking at a few cans at an unknown distance, but this won't tell you very much. The only meaningful test is firing from a solid rest at a known distance. This generally means getting to a target range with permanent bench installations or setting up your own range.

The best kind of shooting bench is a permanent one, with solid legs anchored in concrete.

Portable shooting benches can be homemade or you can buy one of several on the market. The type that has a built-in seat is my recommendation, since with these, the weight of the shooter serves to hold down the bench. The top either has an attached forend rest for the rifle or you can use a sandbag rest on an adjustable base.

Testing should be done on a day with good light, little or no wind and moderate temperatures. Calm conditions are generally found in the early morning or late afternoon. The place to start is with a test of factory ammunition for comparison. Really fine accuracy cannot be obtained without a telescopic sight, since this lets you see exactly where you are aiming. A spotting scope of 20x or more gives you a clear view of a distant target. A distance of 100 yards is good enough to get a fair idea of the long-range performance of your rifle and ammunition, though 200 yards is better. Most shooters use the standard of the "magic inch" at 100 yards as a benchmark by which all rifles are judged. Few hunting rifles will group this well, but will run groups of 2 to 3 inches, which is enough to kill a deer. Shoot 7- or 10-

shot groups, taking your time to carefully squeeze off the shots. Be sure to clean the rifle of all copper fouling before shooting lead-alloy bullets, since they will strip lead on the copper fouling.

Shooting into turf will give you an idea of the ricochet potential of your ammunition, if this is critical. You can usually hear the results if the bullets are not ricochet-proof. For testing on game or varmint animals, there is not much in the way of practical substitutes for the real item. Ballistic gelatin is the standard by which determinations are made, but it is difficult to prepare, and it must be calibrated and used at the proper temperature.

One tissue substitute of a cheap and easy sort is newspaper, soaked overnight to get it fully saturated. Stacks of the wet paper are then put in a cardboard carton for shooting into. This is far heavier and more resistant than muscle tissue, but will give you a general idea of bullet behavior.

Packed wet snow is a fairly good tissue simulant, and if there is enough of it, you can find your bullet somewhere along a long snow loaf. High-velocity spitzer bullets are almost impossible to recover, but lower velocity cast bullets can usually be stopped within 20 to 30 feet of packed snow. These will generally be in almost pristine condition. This will give you a good opportunity to study your bullets for evidence of gas cutting and of how well they take the rifling. Large or double sets of rifling marks on the front of a bullet indicate skidding or jumping the rifling—the bullet going straight for a fraction of an inch before taking the rifling and turning, as it should. Rifling marks that are higher on one side than the other indicate the bullet was not straight

in the case. Poor alignment of this sort degrades accuracy. Grease grooves that are heavily compressed and lack of lubricant will explain one cause of leading—not enough groove space and an inefficient lubricant. Bullet recovery is for those who are seriously interested, those wanting answers to questions beginning with the word "Why."

A final warning is to *always check your cases after firing*, particularly when you are testing loads that are on the high side of the pressure curve. Once you are in the field, there is a great temptation to keep shooting. If there are signs of high pressure or excessive headspace, *stop shooting*. Don't risk your eyesight and your rifle.

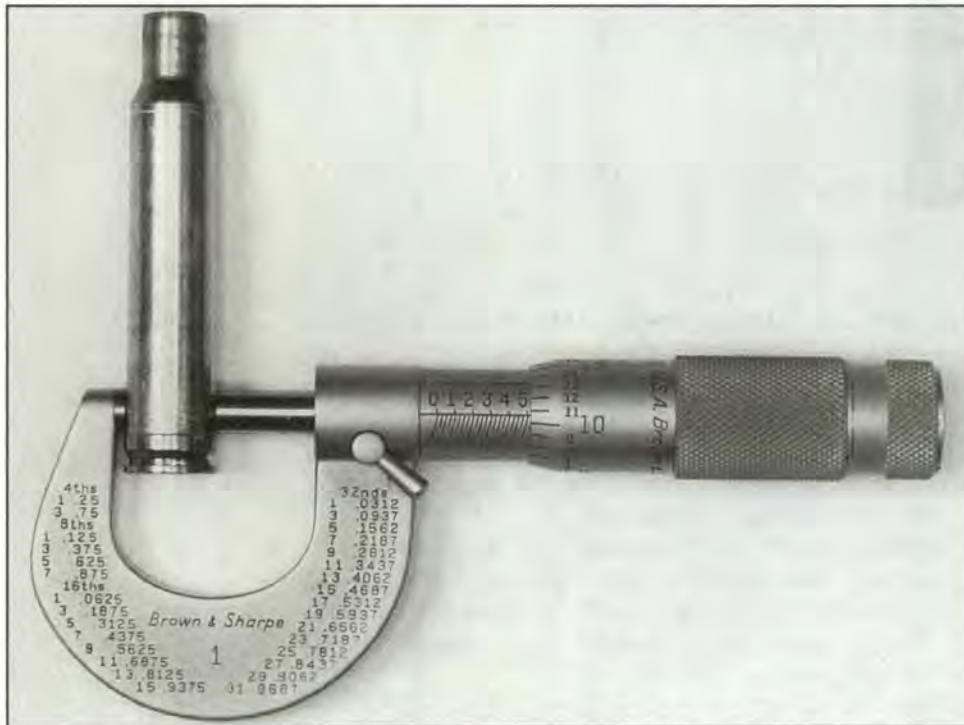

Checking a case for expansion beyond that produced by a factory load (along with stiff extraction) will give you the first indication of excessive pressures. It is a timely warning to tone them down.

Even though your favorite handgun digests all types of factory ammo, you can probably squeeze out a little more performance—and save money, too.

# Handgun Cartridge Reloading

**LOADING HANDGUN AMMUNITION** is perhaps a little easier than loading rifle cases, but the same level of care and attention must be given the task if good results are to be obtained. The place to begin is with once-fired or, better, new cases to work up a load. Once a load is tested and found to be satisfactory, then quantity production can begin and some of the preliminary steps can be omitted.

Handguns come in three basic classes: revolvers, autoloaders (automatics) and single-shot pistols. Each has its own characteristics and will be discussed accordingly. Basic loading procedures apply for all types, but there are special exceptions, which will be given separate attention.



Good accuracy comes from consistency in the quality of your reloads as much as it does from the gun.

## Case inspection

Even new and once-fired cases should be checked over for defects. Any with splits or serious defects in the case mouth that are not ironed out in the resizing die should be discarded. Cases should be segregated by maker, as determined by the head-stamp. Even though they are the same caliber, cases of different manufacture have slight differences in wall thickness and flash hole size. Mixing brands will alter velocities and pressures, and will open up group size.

## Full-length Resizing

New cases should be sized the same as old ones, just to be sure everything is the same. Before any operation can take place on the reloading press, the die must first be adjusted to resize the case properly. For full-length resizing, with the shellholder snapped into the ram, lower the press handle completely; screw the sizer die into the press until the bottom of the die hits the shellholder. (If you are using a carbide die, as is common with handgun calibers, do not allow the shellholder to contact the bottom of the die.) Now, raise the press handle enough so you can screw the die down about 1/8-turn more, then set the large lock ring/nut. Make further adjustments so the bottom of the expander ball is 3/16-inch up inside the die, and the decapping pin should extend 1/8-inch below the mouth of the die, which is just enough to knock out the spent primer. The best bet is to follow the instructions that come with the die set, or take the time to really read a loading manual, which usually will include such instruction.

To resize a case, it must first be given a coating of case lubricant to allow it to work easily in the sizing die. Sizing lubricant is a special oil or grease made for this purpose. Regular gun oil will not work. It is best applied by saturating a case lube pad with lubricant, then rolling the case over it, lightly coating the outside of the case. Too much lubricant on the outside of the case will cause dents in the walls which will flatten out on firing, but will stress the metal. On bottleneck cases, the inside of the neck should be cleaned and lubricated with a dry graphite, or similar non-oil, case neck lubricant. Oil can run into the powder and ruin it. Neck lubricating keeps the neck from stretching unduly in the die.

To begin resizing, the prepared case is inserted in the shell-holder, and the press handle is pulled to run the case completely into the die.

## Decapping

The die should be adjusted so the decapping pin just removes the old primer, which will drop out at the end of the up-stroke. The resizing/decapping process should require a medium amount of force. If a lot of force is required to get the case in the die you have not used enough lubricant, and there's a good chance the case will seize in the die. If that happens, you'll need to send the die back to the manufacturer to remove the case, or buy a tool to do the job yourself.

## Inspection, Gauging and Trimming

The case is now removed from the shell-holder for inspection.

tion. The case mouth should be smooth and perfectly round. "Trim to length" say the books because a too-long case will enter the throat of the barrel and raise pressures as the bullet is pinched in the case. A quick check with a case length gauge or measurement with your caliper tells you if the case is too long. Sometimes even new ones are. If the case is too long, it goes in the trimmer to cut the case to exact length. After trimming, the burr on the outside of the mouth is removed and the inside is chamfered to give the bullet a smooth start. This trimming/chamfering operation only needs to be done when cases get too long. Do not cut a knife-edge on the case mouth, but simply remove the burr.

### Inside Neck Expansion

For bottleneck cartridges, the decapping pin is mounted in a rod with an expansion ball on it that stretches the case mouth large enough to accept a new bullet. This operation is completed on the up, or removal, stroke of the operating handle.

### Case Mouth Expansion

For straight-walled cases being loaded with cast, lead-alloy bullets, this step uses the second die in a three-die pistol set. Three-die sets do not expand the case mouth in the decapping stage. The case is placed in the shellholder and run into this expansion die, which has a stepped

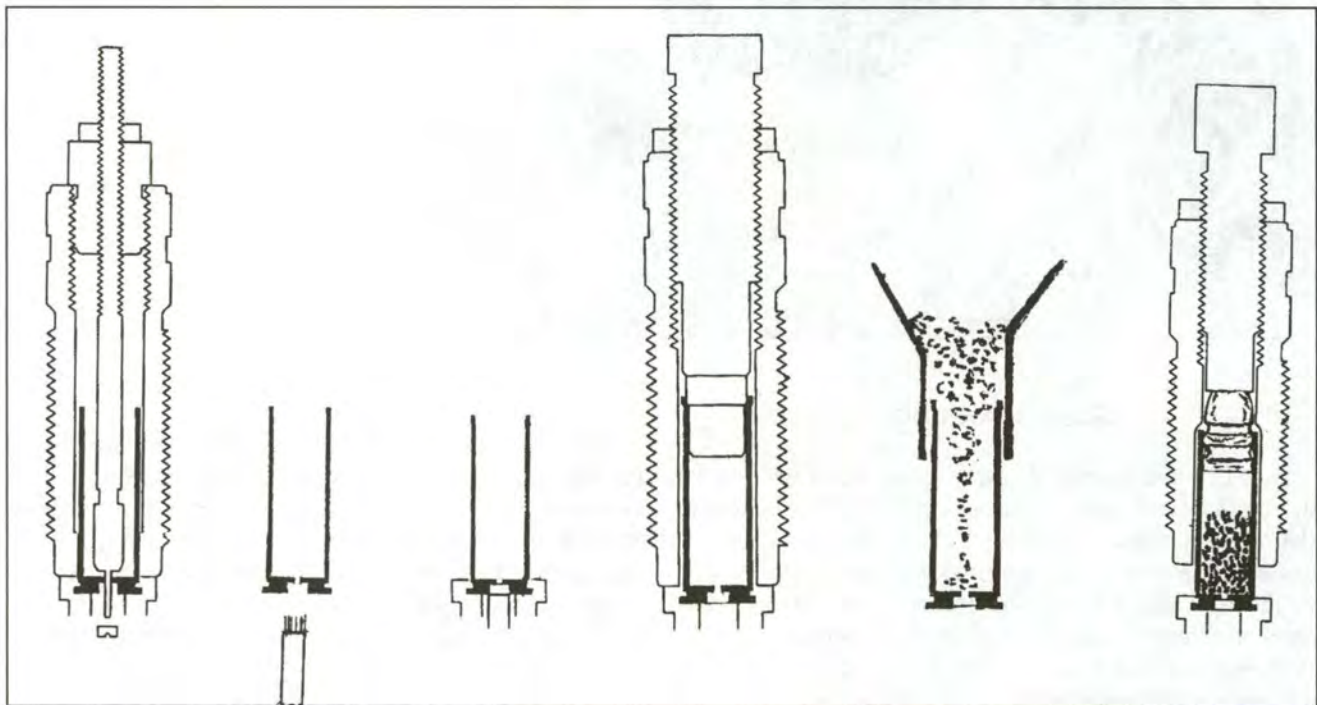

The basic steps in handgun reloading include: resizing and decapping, primer pocket cleaning, priming, case expanding, powder charging and bullet seating.

Case length should be checked after sizing and neck expanding, because the case stretches in these operations.

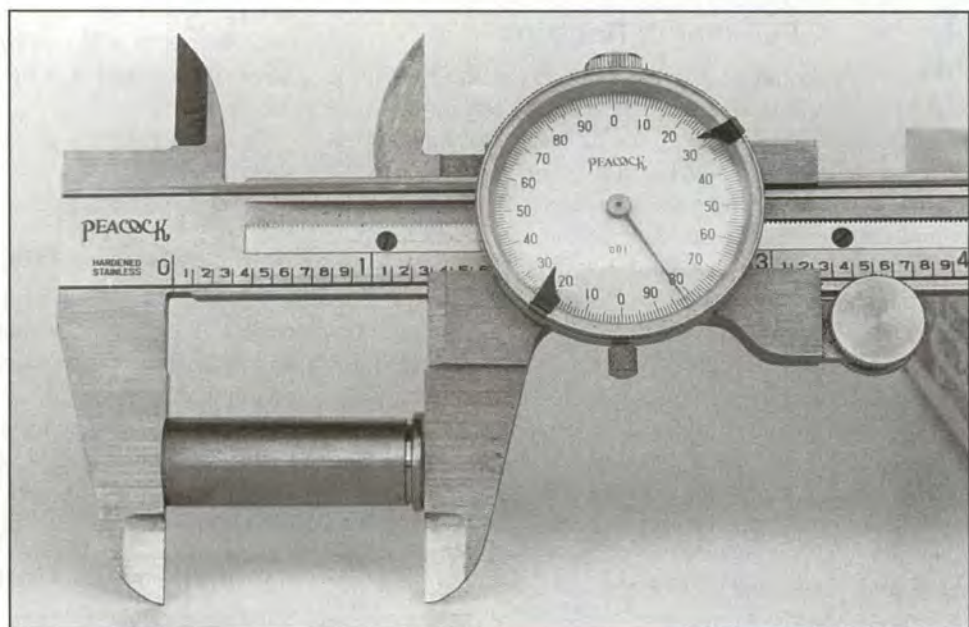



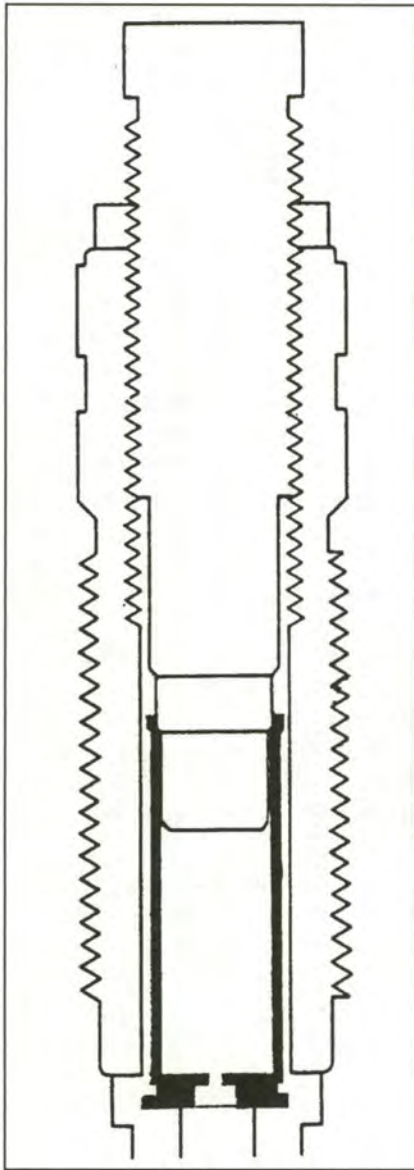

The reloader's powder funnel is especially designed to fit over the case mouth and deliver powder without spills.

Case-mouth expanding, or belling, prepares the case to accept a soft, lead-alloy bullet.

or tapered expander plug that opens the case mouth for insertion of a bullet. This mouth expansion is done before powder charging.

### Priming

If the case is a fired one, the primer pocket should be scraped free of ash with a screwdriver or cleaning tool. The case is now ready for priming. Place a primer in the priming punch sleeve. This comes up, in most cases, through the center of the shell-holder. Place the case in the shell-holder and pull the operating handle to lower the case onto the primer punch. This will seat the primer in the case. Enough force should be applied to seat the primer fully, but not crush or flatten it. Difficulty in seating may be experienced if you are using crimped military brass. If so, this crimp must be removed before proceeding.

After priming, the case should be checked to see that the primer is fully in the pocket. This is done by placing a steel straight-edge ruler across the case while holding it to the light

to see if the primer sticks up above the case head. It should not. A high primer gives poor ignition or may not fire at all as the firing pin simply drives it into the pocket. The primed, inspected case now goes into the loading block.

### Powder Charging

The case is now ready for charging. When working up a load, always start with the beginning load listed in the data manuals. Increases in powder charges should be made by no more than a half-grain (.5) at a time and less than this for hot, fast-burning powders. Load and test fire at least 10 test rounds before going to a heavier charge. Powder charges are weighed precisely on a powder scale for working up loads. The easiest method is dispense slightly less than you want with a powder thrower, weight it in the scale pan, then bring the load to the precise desired weight with a powder trickler.. The scale should be properly set up and checked for adjustment according to the maker's instructions.

Once the charge is weighed, the powder funnel goes on the

case and the powder is poured in, with no spills, of course. The funnel is moved from case to case until every one in the loading block is filled. Make it a habit to check the powder level in all the cases in the loading block, examining them under good light, even though you are sure you did not double charge any of them. If the powder level in any case looks suspiciously high, weigh it again. The balance may be sticking on your scale or you may have accidentally shifted a weight—you'd be surprised at what can happen. Mistakes with pistol powders are more critical than with slower-burning rifle powders. They are more powerful. A little too much Bullseye can go a long way in wrecking your gun.

### Using A Powder Measure

The precision of mechanical powder measures depends to a great degree on *consistency* of pulling and returning the operating handle. After a powder measure is adjusted, check its accuracy, and yours, by dropping every fifth load into the scale pan for weighing. Accurate loads are within a tolerance of  $\pm 1/10$ -grain (.1). Always visually check cases loaded with a powder measure in the loading block. It is very easy to pull the handle twice on the same case. Since



Semi-wadcutter bullets are among the best cast revolver bullets in terms of both accuracy and killing power, which makes them suitable for both target shooting and hunting.

Finished ammunition should be measured to see that the cartridge does not exceed the maximum overall length specified in the loading manual.

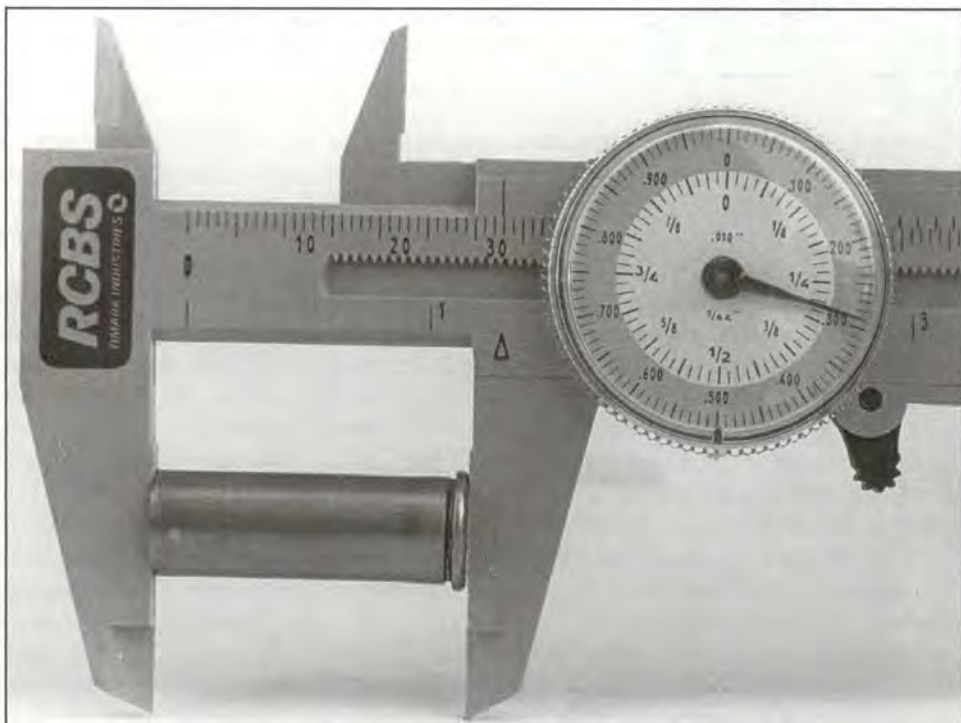

many loads for handguns are nearly full-case loads, a double charge will run over or fill the case to the point where a bullet can't be seated, but don't bet on it.

### Bullet Seating

This is the final step in the loading operation. A case is placed in the shellholder, a bullet is placed in the case mouth as straight as possible, and the case is gently levered into the bullet-seating die. Proper die adjustment is necessary so you don't exceed the *maximum overall length* of the cartridge as listed in the loading manual. An overly long cartridge can press the bullet into the rifling and raise pressures in auto-loaders, or jam them. In revolvers, they will jam the cylinder. The easiest way to avoid this problem is to make up a dummy cartridge to use as a guide. After the die is screwed into the press, adjust it so the case enters freely its full length. Gradually ease the cartridge in the die and check to see it does not pass the crimping shoulder, which turns over the case mouth. The next adjustment is to the stem of the bullet seater, which gradually drives the bullet deeper into the case. When the correct overall length is reached, tighten the seater adjustment. Keep the dummy for easy readjustment after loading longer or shorter bullets. You may want to make a dummy for every different-length bullet you load to facilitate easy readjustment. Once the die is adjusted, bullet seating is simply a matter of repetition.

Most dies have a built-in crimping shoulder to turn the case mouth over into a cannelure (groove) in the bullet. This is necessary for high-powered rifle ammunition, particularly if it is jarred by recoil or while being fed through the magazine. Crimping is necessary on nearly all handgun bullets. Magnum handgun cases require heavy crimping to keep

## Working Up A Load

bullets from being jarred loose by recoil. No rimless automatic cartridge such as the 45 ACP should be crimped since it headspaces on the case mouth and a crimp will allow the case to enter too deeply, giving erratic ignition.

Easy does it is the rule for all steps. Ramming and jerking leads to damaged cases, mashed bullets, flattened primers and broken decapping pins.

The final step is to wipe off any case lubricant that may be on the case and inspect the finished cartridge with a final check for overall length. Oil left on cases will cause excessive back-thrust and batter your gun. If all dies are properly adjusted and firmly in place, there should be no difference from one cartridge to the next. Place the loaded rounds in a cartridge box and mark it accordingly.

Cleaning the loading area is always a good idea. Powder should always be returned to the original container, especially from the powder measure. Powder in open containers will lose volatiles and absorb moisture. Primers can absorb moisture and magnum and standard primers can be confused if not put back in their respective containers. Most of all, there is always the chance of confusion regarding what powder you were using when you start the next time.

### Selecting A Load

Many people start with factory duplication loads, which, if you have already been shooting them, is a convenient place to start without varying any component. Generally, though, the best accuracy in your handgun will be something you work up on your own. This may take some doing even though many loading manuals list "accuracy loads." If you read the fine print you will see this applies to one particular test gun. If yours is a different make, this one may not shoot best for you, but it is perhaps the best powder/bullet combination to start with. Loading data is presented as starting loads and maximum loads with a middle ground in between. It is generally in this middle ground where the most accurate loading will be found. Rarely is the hottest, highest-pressure load the straightest shooter. Maximum loads, especially with jacketed bullets, shorten both case and barrel life. By working for accuracy, you start by getting a clear idea of just how well your handgun will shoot. With this as a starting point, you then have a standard by which other loads can be judged.

For the most part, you will probably not have need for more than three or four different loadings, if that many. On the bottom end are short-range practice loads. These are usually cast bullets driven at modest velocities of around 550-750 fps. These offer good, cheap recreation and training without the expense, wear, noise and recoil of full-bore loads. They can be used for short-range target shooting where noise may be a problem. Hunting loads are really for handguns of the 357 Magnum class and up. These are near maximum pressure and velocity loadings with jacketed expanding bullets. You would do best to work up the most accurate load you can from the selection of hunting bullets available.

Working up a load means not merely careful loading of ammunition, but testing it and keeping records of the results. It also involves case inspection, looking for any signs of excessive headspace or pressures. Use a simple notebook for records. List these under the name of the gun and its caliber. Individual loads are listed under the bullet, indicating whether it is cast or jacketed, the weight, diameter and lubrication type. Next, the powder type and charge are shown. Following this is a notation on the make of case and primer and type. Finally, there's a section for remarks. This includes a summary of the performance of this particular load, especially its accuracy. Ten-shot groups are the accuracy test standard, although it has been demonstrated that seven-shot groups work just as well. Other remarks include the test range conditions like temperature, wind direction and velocity and fight conditions. Also noted are any indications of pressure problems. These are underlined as a warning for future reference.

### Loading for Autoloaders

Since the 1980s autoloaders in all calibers and types have become very popular, owing mainly to the changeover by nearly all of this country's police departments to this type of handgun for duty carry. While all autoloaders rely on the force of the explosion in the cartridge to function the action, there are a number of differences in the ways various actions operate, and these features have a marked effect on how ammunition must be reloaded for them.

There are three basic types of autoloading actions: straight blowback, with a variant known as delayed blowback, recoil-operated and gas-operated.

Blowback actions are the simplest. They function by having the slide held in contact with the barrel by a spring, thus the two are not locked together. When the gun fires, the bullet is driven down the barrel while the case is driven against the face of the slide. The weight of the slide and force of the recoil spring, and the internal pressure swelling the case against the chamber wall, all keep the case from moving backward until the bullet has exited the muzzle. Somewhere around this point, as chamber pressure begins to drop, the case begins to be blown back against the slide; the inertial force given the slide causes it to move rearward, cocking the pistol and ejecting the fired case. Tension in the compressed recoil spring sends the slide forward, stripping a fresh cartridge from the magazine and chambering it. This system works well with low-powered handgun cartridges and is used in all 22 Long Rifle, 25 ACP, 32 ACP, 380 ACP autoloaders and the 9mm Makarov autoloading pistol. The system is limited to straight-walled, semi-rimmed cases because a bottlenecked case would likely have its neck pulled off or have gas come rushing around it as soon as the pressure seal was broken. Because of the necessity of equaling the forces of the forward-moving bullet with the proper amount of slide weight and spring pressure, limitations of the system

*(Text continued on page 126)*

# Step-By-Step Reloading

## Handgun Cartridges

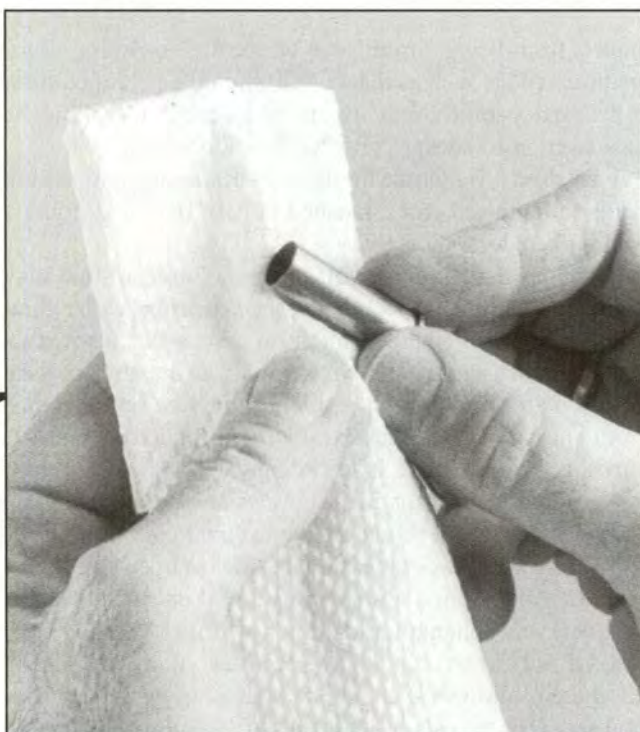

**Step 1 - Clean and Inspect:** It's a good idea to wipe cases clean before beginning to reload them. This also allows you to inspect them for any split necks, cracks, etc. Discard those that are damaged.

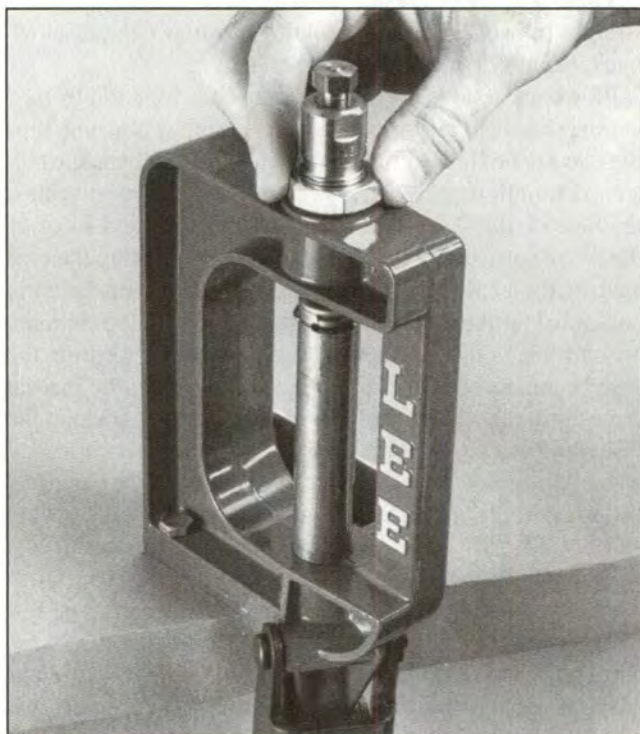

**Step 4 - Adjusting the Sizer Die:** Raise the ram to the top of its travel and screw the sizing die in until it just touches the shellholder. Now, slightly lower the ram and screw in the die an additional 1/4-turn. Tighten the lock nut.

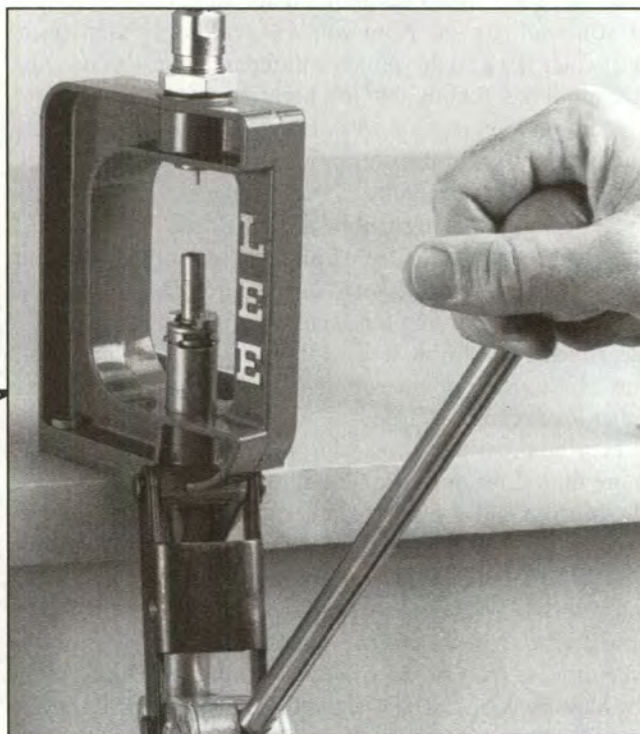

**Step 5 - Case Resizing:** Place a lubed case in the shellholder and raise the ram, guiding the case as it enters the sizing die. This step also knocks out the fired primer. Raise the press handle and remove the case.

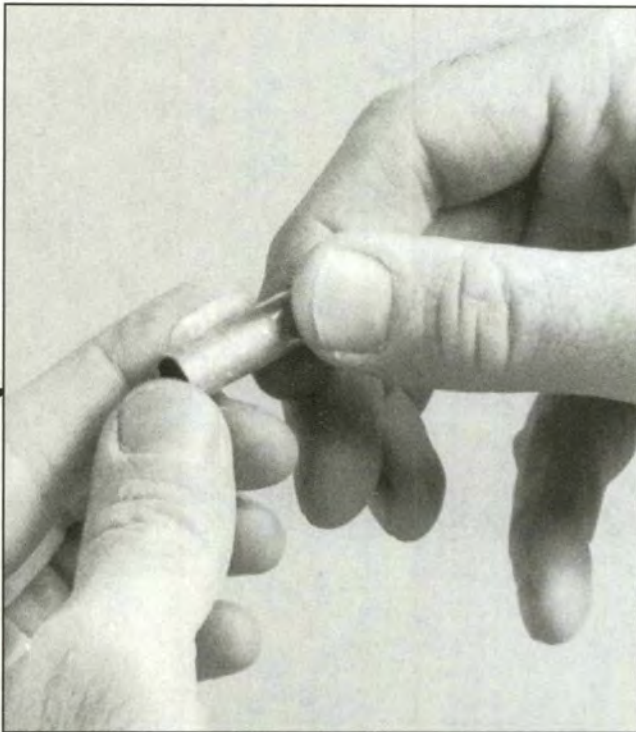

**Step 2 - Lubricate the Cases:** Case lube is needed when not using a carbide resizing die. Spread just a light film on each case with the fingers.

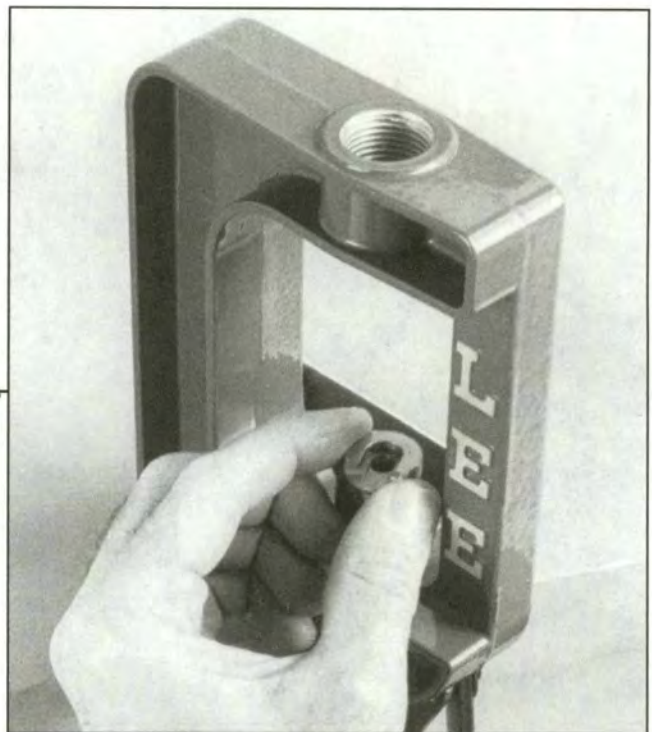

**Step 3 - Installing the Shellholder:** Choose the proper shellholder for the round you are loading. They usually come with the die sets. Raise the ram slightly to snap the shellholder into place with a twisting motion. Position it with the open side out to the left.

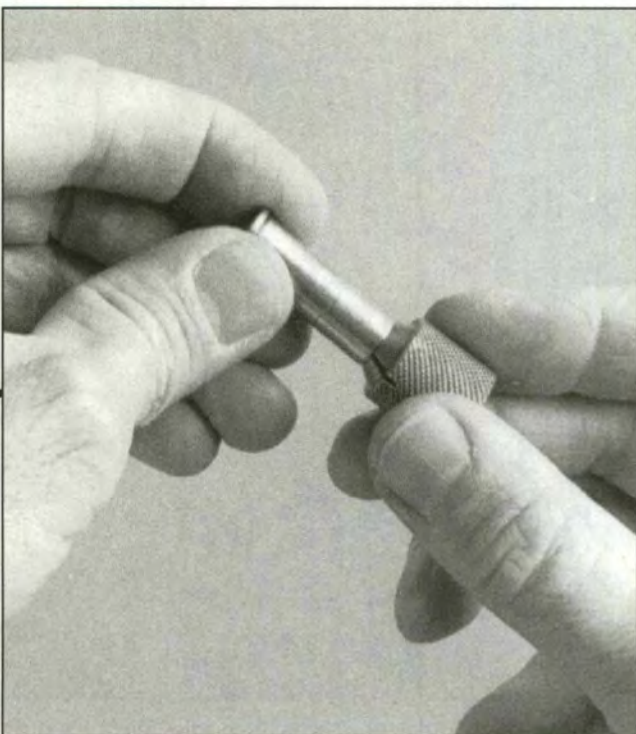

**Step 6 - Chamfer and Deburr:** To ease bullet entry, lightly chamfer the mouth of the case by inserting the pointed end of the chamfering/deburring tool into the case mouth and gently twisting it.



**Step 7 - Case Mouth Expansion:** After installing and properly adjusting the expander die, insert a case and run it into the die to bell the case mouth for easy insertion of a new bullet. Adjust the die just enough to allow easy bullet entry.

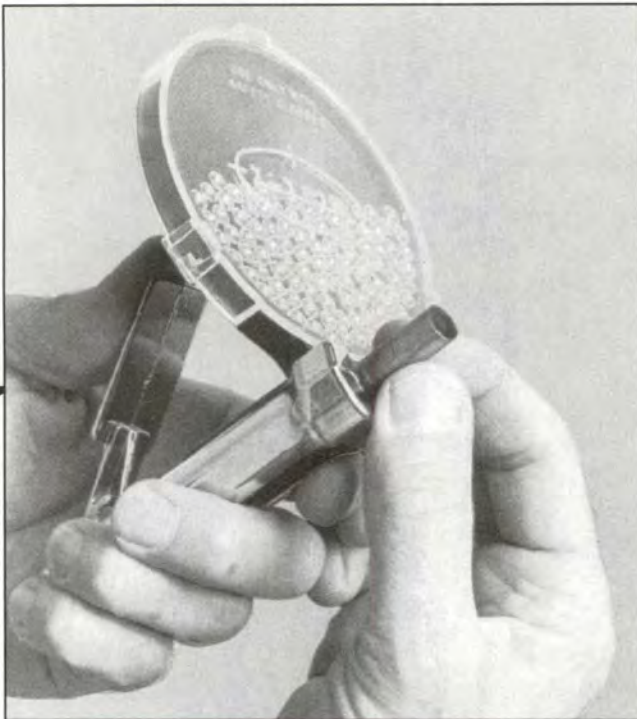

**Step 8 - Priming:** Installing a new primer can be done on the press or with a hand-held Auto Prime tool. After filling the primer tray, slip a deprimed case into the shellholder and press the lever to push a primer into the primer pocket. Follow the instructions that come with each tool.



**Step 9 - Powder Charging (A):** Find the proper and safe load for your cartridge in a loading manual or from another reliable source, then weigh each charge on your powder scale. This is the safest method, although a bit slow, and is best for accuracy and maximum loads.

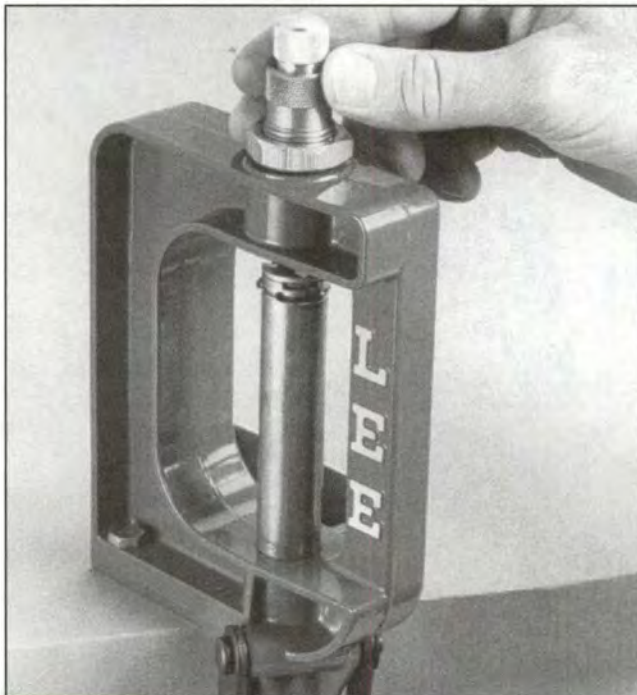

**Step 12 - Bullet Seating (A):** To install the bullet-seating die, place a case in the shellholder and raise the ram to the top of the stroke. Screw in the seater die until you feel it touch the case mouth. If no crimp is desired, back the die out 1/2-turn. If you want a crimp, turn it in 1/4-turn.

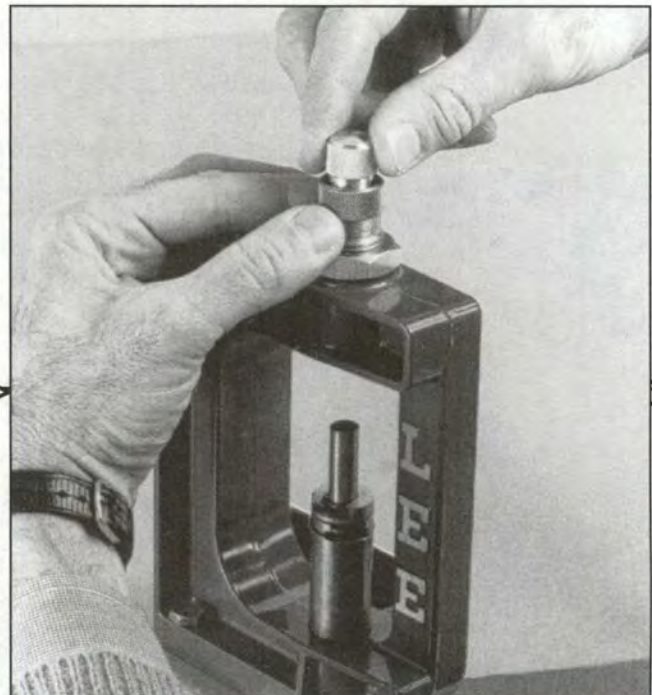

**Step 13 - Bullet Seating (B):** The knurled adjusting screw controls the bullet seating depth. Usually, seating to the same depth as a factory round works well. If you want a crimp, be sure the bullet cannelure is almost completely inside the case mouth. Screw the die in just enough to apply a good crimp. A little trial and error work is needed here.

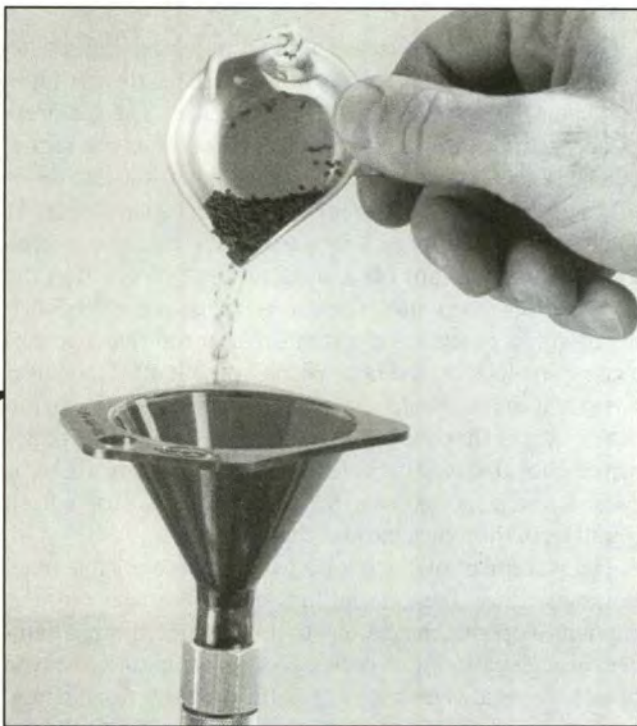

**Step 10 - Powder Charging (B):** Lee's expander die allows the powder charge to be dumped from the scale pan into the primed case through the die. Cases can also be set into a loading block for powder charging.

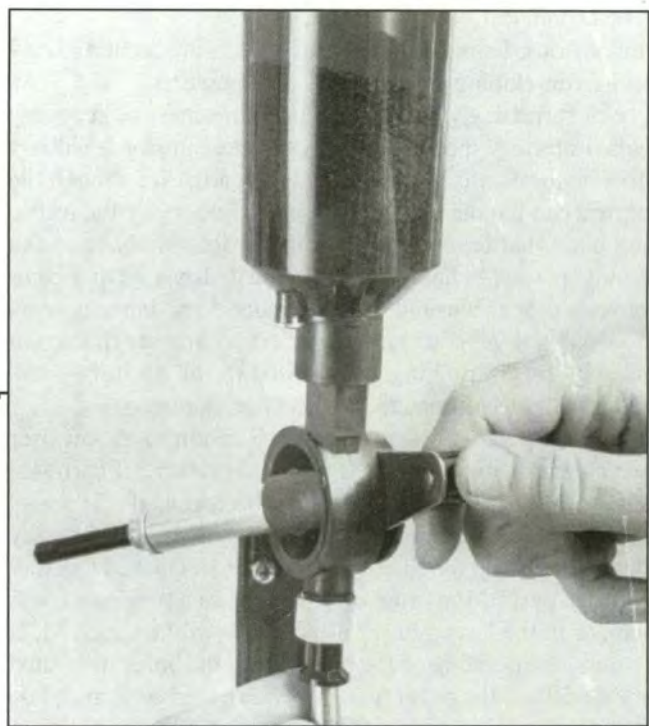

**Step 11 - Powder Charging (C):** Once the proper load has been found, you can dispense powder directly into the case with the powder measure. It will throw a precise, uniform charge with each turn of the handle. Check-weigh every fifth or tenth charge to be sure it is correct.



**Step 14 - Bullet Seating (C):** To seat a bullet, place one in the case mouth and guide it into the seating die as straight as possible. If the bullet needs to be deeper, screw in the seater plug a little bit and run the case back into the die. It may take a few tries to get the exact depth required.



**Step 15 - The Loaded Round:** That's all there is to loading a handgun cartridge. A final wipe with a clean cloth and the ammunition is ready to be fired. Don't forget to mark the ammo box with your load data so you can repeat the load.

*(Text continued from page 121)*

are obvious. Thus, blowback autoloaders are limited to cartridges developing low velocities and pressures.

Not surprisingly, reloads for such guns must be kept very close to factory specifications. Lower-pressure loads will not operate the action and high-pressure loads, even though the barrels can handle them, increase the velocity of the recoiling parts, battering them, causing serious damage to the handgun. Cast bullet loads work well if they are crimped to provide proper burning of the powder. Slow-burning powders will not generate enough power to operate the action reliably. Taper-crimping, as opposed to roll or "turn-over" crimping, is recommended for best functioning.

Recoil-operated actions represent an improvement over the blowback in terms of the type and pressure of cartridge they can handle. In this system, the recoil of the pistol drives the operation. Recoil operated systems are generally designed to keep the slide or bolt and barrel locked together through part of the firing cycle. Some use a toggle-link system, as in the Luger, or a roller-lock, as in the Czech M52, to delay the opening of the breech until the bullet has exited the barrel. As the bullet travels forward, the barrel and slide recoil as a unit. At about the midpoint of the operation, after the bullet has exited the barrel, pressure drops, the action unlocks and the slide continues traveling backward, ejecting the empty case and cocking the hammer. The slide then strips a fresh round from the magazine, chambering it as it comes forward into battery.

This system is used in autoloading pistols using the 9mm Parabellum cartridge, 38 Super Auto, 45 ACP and similar cartridges adopted for military and police use. Battering of internal parts will result from loads generating excessive pressures and velocities.

The best way to work up handloads for autoloaders is to do so slowly, checking recoiling parts for any evidence of battering. The best loads are ones that will reliably cycle the action and no more.

Generally the only cast-bullet loads that do work are those near the maximum pressure level. While these may operate the action reliably, they may often not deliver very good accuracy, and the accurate load may not operate the action. Reduced loads will not work reliably in any autoloader, with cartridges often getting jammed on the way out and chewed up in the process. Therefore, the range of loading options for autoloaders of any stripe is rather limited. There will usually be only a relative few loadings that will produce good accuracy and reliable functioning. Ammunition prepared for autoloaders should be given extra care to see that all tolerances are kept close to factory specifications. Exceeding overall length will jam actions. Cases too short and bullets too deep can have the same effect. In short, ammunition preparation for successful shooting of these guns requires extra care for best results.

Full-length resizing is almost always necessary with cartridges used in autoloaders, since the chambers are on the large size to permit reliable feeding even when they are dirty with fouling.

Gas-operated pistols are uncommon and limited to expensive models that fire very powerful magnum cartridges that enter the lower region of rifle velocities. The gas-operated system features a locked bolt and non-moving barrel, much like gas-operated rifles, and is based on a scaled-down rifle action. They can thus fire very powerful cartridges. At some point on the barrel, forward of the chamber, there's a small hole that taps off a small amount of gas after the bullet passes that point. The gas is trapped in a small cylinder with a piston. The piston drives a rod that operates a camming lock on the bolt, which opens it after the bullet has exited the barrel. In some variants the gas is directed to the surface of the cam lock to unlock the bolt. As the bolt is driven back, the case is ejected and the hammer or striker is cocked, and a spring drives the bolt forward to strip a fresh round from the magazine and chamber it.

The placement of the gas port is critical to reliable functioning because the amount and pressure of gas must be enough to operate the pistol, but not enough to cause damage through battering. Needless to say, the amount and type of powder used is also critical to this system's functioning. Gas-operated autoloaders are ammunition-sensitive and will work best with loadings that duplicate factory specifications. Cast bullets, generally, do not work well in gas-operated autoloaders. Fast-burning powders such as IMR 4227, Herco, Unique, 2400, H 110 and AA 1680 are about the only ones that will function gas-operated actions reliably.

Any cast bullets used in autoloading pistols are best cast of hard alloy, since soft bullets are often nicked and dented as they pass through the magazine and into the chamber. Feed ramp polishing may often be necessary when using cast loads with any autoloader to avoid jams. Magazine lips that are bent or sprung are a frequent cause of jamming in autoloading pistols and should be checked for wear or damage if this problem occurs.

## Loading for Revolvers

Modern revolvers are all of the solid frame type. The few exceptions are replicas of 19th century top-break guns and those old models that are still around that use this system. The top-break guns are of a weaker design and should be used only with low-pressure "starting loads" listed in the manuals, and then only if they are in good, tight condition.

Unlike the autoloader, with its box magazine, the revolver features a cylinder with multiple chambers. The mechanism in a revolver turns these chambers, via a hand or pawl that aligns each with the barrel. The relationship between this rotation and the firing cycle is referred to as timing. In revolvers where the timing is off because of wear and battering by too many heavy loads, this alignment between the chamber and the barrel may be less than perfect, poor accuracy—even badly shaved bullets—can result. To an extent, a competent gunsmith can correct this.

The revolver has a second problem—the gap between the cylinder and the barrel. The bullet must jump this gap before entering the forcing cone at the rear of the barrel.



The Colt Gold Cup National Match in 45 ACP is a fine example of a recoil-operated autoloading pistol.



The Wildey automatic pistol is probably the most powerful autoloader around, and the only one currently made that uses a gas-operated system.



The 380 ACP SIG-Super Model P230 is a typical small-frame blowback autoloading pistol.

There has been much written about gas loss in the process, but the final analysis is that it isn't that much in terms of lowering bullet performance. The jump is most detrimental to accuracy because of the aforementioned alignment problems. In addition, by making this jump, the bullet gains a fair amount of speed before it hits the rifling, and may show skid marks as it moves forward for a fraction of an inch before engaging the rifling.

The throat of the revolver cylinder guides but does not really support the bullet, since it is larger than the bore diameter. Sizing revolver bullets is then something of a guessing game. The best course of action is to stick with factory diameters to start with, then experiment with different diameters after slugging the bore. The hardness of cast revolver bullets can have a decided effect on their accuracy. A fairly hard alloy (Lyman #2) generally works best, but softer alloys may be necessary to achieve proper upset and to avoid leading in some revolvers. Leading can be a serious problem in some guns, and these may require a hollow-base bullet to obturate the cylinder throat to avoid hot gas blowing by and melting the surface of the bullet. Before going to a hollow-base mould, it is best to experiment with different lubricants and alloys to see if changes in these will eliminate the problem. Different styles of bullets with larger, deeper lubricant grooves to hold more lubricant may be the answer. Failing that, buy some commercially-made hollow-base bullets or factory loads with hollow-base bullets (if available) before getting another mould. Gas checks and wax wads may come to the rescue in some cases, as will half-jacketed bullets that eliminate leading entirely.

Because they are loaded manually, revolvers work well with cast bullets, both plain and gas-checked. Owing to the recoil a cylinder-full of ammunition receives with each discharge, revolver cartridges should be crimped to keep the bullets from being pushed into the cases. Revolver cases should be full-length resized for ease in loading the gun.

One major advantage of revolvers over autoloaders is their ability to handle low-pressure/low-velocity loadings, because the action is not dependent on cartridge power for operation. These will afford economical practice with minimal wear and tear on the gun. For the same reason, revolvers can take a greater range of bullets in terms of weight and length. Bullets with a long bearing surface generally align better and produce the best accuracy. While revolvers function best with fast-burning pistol powders, the range of loading possibilities surpasses that of the autoloader.

### Loading for Single Shots

These handguns are a fairly recent arrival on the shooting scene, and their use is limited to long-range target shooting and hunting. They chamber rifle cartridges and powerfully loaded handgun cartridges. Because of their solid actions and longer barrels, they generate velocities and pressures in the rifle class. These guns might best be called "hand rifles." Owing to their light weight, most cannot use maximum rifle loadings, and even with more modest pressures and velocities the muzzle blast and recoil are formidable. Most loading manuals contain special loading data for these guns. To use *any* of these loadings in a standard revolver or autoloader would wreck it in short order. Loading procedures for metallic silhouette guns follow rifle instructions. One of the more popular of these guns is the Thompson/Center Contender. This gun allows the use of a number of barrels, each in a different caliber. Contenders can thus shoot anything from the 22 Long Rifle on up to the 45-70, which if you want to get a real "kick" out of handgun shooting will certainly deliver the goods.

### Testing Ammunition

Accuracy is, or should be, your first concern. An accuracy test can consist of nothing more than plinking a few cans at an unknown distance, but this won't tell you very much. The



Although made of modern steel, this top-break replica of the S&W Schofield revolver by Navy Arms probably should not be fired with maximum-pressure loads.



The Thompson/Center Contender (left) and Magnum Research Lone Eagle (above) represent the ultimate in handgun power, range, recoil and noise in calibers such as 45-70, 30-06 and 444 Marlin.

only meaningful test is firing from a solid rest at a known distance. With handguns, a test range doesn't really need much more than 50 yards, since this is about the maximum accurate range of most of them, and 50 to 75 feet is the standard distance. Accuracy testing requires a solid bench installation with a sand bag or adjustable rest. If you live in a rural area or have access to a range with benches, you are set.

Testing should be done on a day with good light, little or no wind and moderate temperatures. Calm conditions are generally found in the early morning or late afternoon. The place to start is to shoot some factory ammunition for comparison. A distance of 50 yards is good enough to get a fair idea of the long-range possibilities of your handgun and ammunition if you plan to use it for hunting. Only the more powerful cartridges – 357 Magnum and up – have much use in the hunting field.

For most handguns, a 2- to 3-inch group at 50 feet is about as good as you will get. Fine target guns will shoot under an inch at this range. Metallic silhouette guns are judged and tested more by rifle standards. Shoot seven- or ten-shot groups, taking your time to squeeze off the shots. If you intend to shoot both cast and jacketed bullets, be sure to clean the barrel of all copper fouling before shooting lead-alloy bullets, since they will strip lead on the copper fouling.

Shooting into turf will give you an idea of the ricochet potential of your ammunition if this is critical. You can usually hear the results if the bullets are not ricochet proof. Most handgun bullets ricochet very readily, even hollow-points. For testing on game or varmint animals, there is not much in the way of practical substitutes for the real item. Ballistic gelatin is the standard by which such deter-

minations are made, but it is difficult to prepare and must be calibrated and used at the proper temperature.

One tissue substitute of a cheap and easy sort is newspaper, soaked overnight to get it fully saturated. Stocks of the wet paper are then put in a cardboard carton for shooting into. This is far heavier and more resistant than muscle tissue, but will give you an idea of bullet behavior.

Packed wet snow is a fairly good tissue simulator, and if there is enough of it you can find your bullet somewhere along a long snow loaf. High-velocity bullets are more difficult to recover, but lower velocity cast bullets can usually be stopped within 5 to 10 feet of packed snow. These will generally be in almost pristine condition. This will give you a good opportunity to study your cast bullets for evidence of gas-cutting and of how well they take the rifling. Large or double sets of rifling marks on the front of a bullet indicate skidding or jumping the rifling—the bullet going straight for a fraction of an inch before taking the rifling and turning, as it should. Rifling marks that are higher on one side than the other indicate the bullet was not straight in the case or were fired in a revolver with the cylinder slightly out of alignment. Grease grooves that are heavily compressed and lack lubricant will explain one cause of leading—not enough groove space and an inefficient lubricant. Bullet recovery is for those who are seriously interested, and those wanting answers to questions beginning with the word “Why.”

A final warning is to *always check your cases after firing*, particularly when you are testing loads that are on the high side of the pressure curve. Once you are out in the field, there is a great temptation to keep shooting. If there are signs of high pressure or excessive headspace, *stop shooting*. Don't risk your eyesight and handgun.

Creating homemade scattergun fodder is not the same as metallic cartridge reloading. It requires different tools, components and knowledge.

# Shotshell Ammunition Reloading

**OF THE THREE** basic types of ammunition, shotgun ammunition is perhaps the easiest to load, once you get the hang of it. Nevertheless, the same level of care and attention must be given the task if good results are to be obtained. The place to begin is with once-fired or new cases to work up a load. Once a load is tested and found to be satisfactory then quantity production can begin.

Shotshell casings are made of plastic for the most part. Since shotshells operate at far lower pressures than rifle and most handgun ammunition, they are less robust in construction. Shotshells come in six sizes or gauges. The smallest is the .410-bore which is actually .410-inch in diameter or 410-caliber. The larger sizes are listed by gauge, an old system that determined a "gauge" size by the number of lead balls of that diameter to weigh a pound. The next size up is 28-gauge, then 20-gauge, 16-gauge, 12-gauge and, finally, 10-gauge. In the bad old days of market hunting, the now obsolete 8-gauge, 4-gauge and even 3-gauge guns were used; the latter two were mounted like small

Modern shotshells, from left: 10-gauge 3 1/2-inch magnum, 12-gauge 3-inch, 12-gauge 2 3/4-inch, 16-gauge 2 3/4-inch, 20-gauge 2 3/4-inch, 28-gauge 2 3/4-inch, and .410 bore 3- and 2 1/2-inch.



cannons on boats for taking waterfowl. Modern shotshells, in addition to the above six gauges, are available in different lengths. Since 1933, .410 shotguns have been universally available to take the 3-inch shell, which is ballistically superior to the old 2 1/2-inch shell. The 3-inch shell should never be loaded in a gun chambered for the shorter shell. This rule applies to all gauges. To do so will result in serious pressure jumps, which can wreck your gun and your face. The shorter shell can always be used in the longer chamber, but never the reverse.

The big problem with this potential mismatching of length is that the longer shells will chamber in guns intended for the shorter load. This is because shotgun chambers are made long, allowing space for the opening of the crimp in the case mouth. A 3 1/2-inch 10-gauge shell measures 3 inches unfired, and 3 1/2 inches fired. If you have an old gun, or one of foreign make that is not marked for the length of shell it is chambered for, take it to a competent gunsmith for examination. Foreign shotguns may be chambered for shells of different lengths.

Old guns should be regarded with suspicion unless the length is clearly marked or can otherwise be identified. Old guns should also be regarded as suspect if they cannot be identified as being safe for use with modern smokeless powder. Guns with damascus barrels, identifiable by the tiger-stripe pattern in the metal, should be examined by a knowledgeable gunsmith to determine if the barrels are sound. If there is any sign of barrel corrosion from blackpowder loads used in the gun, don't try shooting it. Damascus-barreled guns in good condition should be used with blackpowder loads only, just to be on the safe, lower-pressure side. Guns designed for smokeless loads abound on the new and used market, so it's not worth the risk of blowing up Granpap's old double, let alone your hide, just to shoot the thing. Again, if there is *any* doubt about the soundness of the gun, don't shoot it at all.

### Case Inspection and Storage

As with rifle and handgun cartridges, shotshells should be inspected for defects. Those that are badly worn around the mouth, have splits in the case walls or heads, or leaks

around the primers, should be discarded. Paper shotshells are perhaps the most vulnerable of all. The bodies absorb moisture, which can also enter the seam around the primer, and moisture-swollen shells will not chamber. Before buying any old ones to shoot, if the shells can't be tested, try chambering the more suspect ones or check them with a ring gauge. Study the exteriors for bleaching or water discoloration.

Modern plastic shells don't have this problem, but in an economy move many are no longer made with brass heads. The steel heads are given a thin brass plating which will corrode quickly. The steel beneath will corrode even more quickly if exposed to pollutants. Old plastic shells that have been crimped for a long time tend to hold that crimp and reload poorly unless ironed out with a warming tool made for this purpose. A piece of metal rod or pipe of the proper diameter heated in boiling water will also serve.

Shotshells come in a wide array of colors. There is a good reason for this so you won't mix them up. Successful reloading depends on fitting all the components together correctly within the shell. There is a considerable difference in the inside capacities of various shells owing to the thickness of the base wad at the head of the shell. Matching loads to the particular brand and type of shell is critical to successful reloading. If the correct shotcup/wad is not used with the matching shell, it may be too long or too short for the shell to crimp properly. Therefore, different companies make their shells in certain colors to identify the make and further color-code these shells by gauge so they are not mixed up. A 20-gauge shell accidentally dropped in a 12-gauge gun barrel will stop about where the forcing cone is. If a 12-gauge shell is then fired, the shooter will immediately be reminded of the Big Bang Theory when the gun comes apart in the forend area. The bad part of this is the proximity of fingers and hand to the barrel that just let go. This 12/20 blowup is not uncommon, and that is why all modern American-made 20-gauge shells are some shade of yellow and all 12-gauges are usually red. Winchester uses red for all its shells except 20-gauge; Remington shells are green, 20-gauge excepted; Federal shells, including their paper-tube 12-gauge, are maroon, with the exception of the 10-gauge which is brown;

There are seven steps in shot-shell reloading: resizing and decapping, priming, powder charging, wad seating, shot metering, crimp starting and crimp finishing.

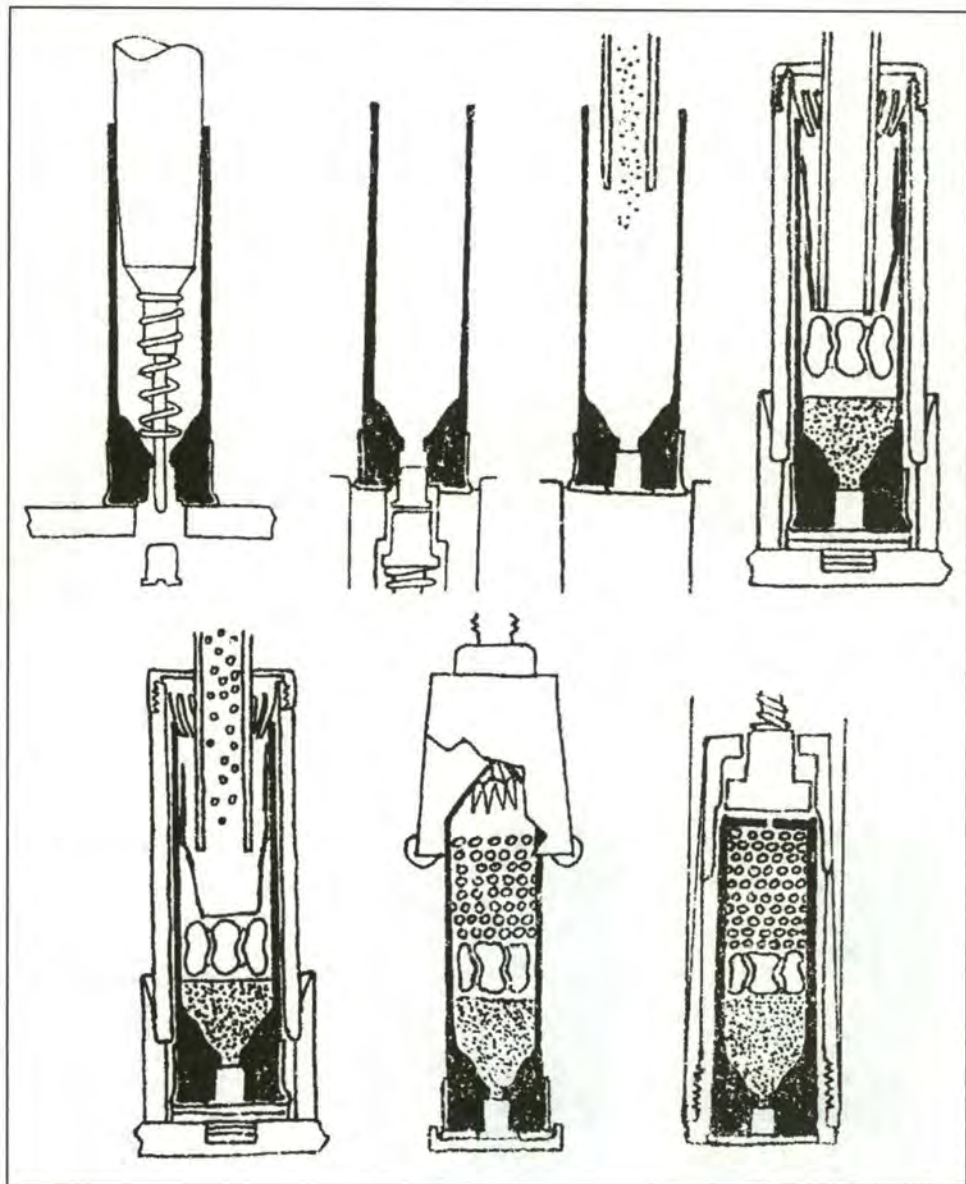

the Activ 12-gauge, which is all plastic and has no brass on it, is red; Fiocchi shells, from Italy, may be purple, blue, red, orange or brown.

Within the various makes you will find shells with different base wads, which thus require different shot cups. That is why critical inspection and storage are needed. If you are in doubt, consult a good shotshell reloading manual, such

as the one put out by Lyman, which has a great many of these shells pictured in color, and of actual size. If in doubt about the proper shot cup, sacrifice a loaded one by cutting it down the middle and comparing the sectioned shell with these illustrations. The height of the brass on the outside of the head may or may not indicate a base wad of a different height, but don't count on it. Never mix components.

#### NORMAL CHOKE PERCENTAGE

Designation	Percentage of Pellets in 30-inch Circle at 40 Yards
Full	65-75
Improved Modified ( $\frac{3}{4}$ )	60-65
Modified ( $\frac{1}{2}$ )	55-65
Improved Cylinder ( $\frac{1}{4}$ )	45-55
Skeet	40-50
Cylinder	35-40

#### SHOTSHELL LENGTHS

Ammo	Shell Length (ins.)
10-Gauge	$2\frac{7}{8}$ (obsolete) and $3\frac{1}{2}$
12-Gauge	$2\frac{3}{4}$ , 3 and $3\frac{1}{2}$
16-Gauge	$2\frac{9}{16}$ (obsolete) and $2\frac{3}{4}$
20-Gauge	$2\frac{3}{4}$ and 3
28-Gauge	$2\frac{3}{4}$
410-Bore	$2\frac{1}{2}$ and 3

## Shotshell Primers

Shotshell primers, while they are all the same size, do have different burning characteristics. This will radically affect pressures. The substitution of one primer for another can raise pressures as much as 2000 psi with all other components being equal. This is why when working up loads, no substitution should be made for *any* component listed in a loading manual. If you have several brands of primers on hand, don't have more than one box open at a time so they don't get mixed up. Primers should be seated flush with the case head. High primers can be detonated accidentally in certain guns with disastrous results. Decapping live primers is not a good idea. Either snap them in the gun or discard the shell.

## Shotshell Wads

Old-style brass and paper shotshells used wads of cardboard, felt and similar fibers to serve as spacers between the powder and the charge of shot. This system was used for over a hundred years. It had a serious drawback—the wads did not obturate the shell or the bore of the gun very well,

and hot powder gas leaked around their edges and melted and otherwise distorted the pellets in the shot charge. Things improved in the 1940s with the addition of a cup wad over the powder to act as a gas seal. In the early 1960s, a further improvement was made with a plastic wrap being placed around the shot charge to keep it from being distorted by direct contact with the barrel.

Modern shotshells contain a single plastic wad with a cup-shaped base that goes over the powder and expands to obturate the bore. Above this is a cushioning section that compresses on firing to start the shot charge off more gently. At the top is a cup that holds the charge of shot. The sides are cut into several "petals" which open as soon as the wad exits the barrel. Unlike in the old days, when loads were assembled by adding card or fiber wads of varying thickness to get the proper height for good crimping, modern wads with shotcups are designed to hold a certain amount of shot. This way, low-volume wads with shallow shotcups are used for light field and target loads, while high-volume wads are used for heavy loads for waterfowl shooting. Attempting to over- or underload these cups gives poor results when you crimp the shell. Components should be properly matched to the shells for which they are intended, and not used in other shells.

## Sizes and Types of Shot

Most shot is made of lead hardened with antimony. So called "premium" shot is made of a harder alloy to keep it from deforming in the firing process. This is a good investment since deformed shot makes for open or irregular patterns, which translates to missed or crippled game. Sometimes hard shot is given a copper plating to make it look attractive. Whether this makes it shoot any better or not depends on your powers of imagination.

Steel shot was introduced some 25 years ago after the U.S. Fish and Wildlife Service concluded that bottom-feeding waterfowl were succumbing to lead poisoning. USFWS placed a ban on lead shot for waterfowl hunting, and thus steel shot was born. Steel shot has a number of drawbacks, the least of which is its light weight. Thus, larger shot must be loaded in greater volume to get the same weight equivalent as the old lead loads. While the hardness of the shot makes it less subject to deformation than lead shot, it also means that steel shot will ruin a standard shotgun barrel and should never be fired in it. To do so will likely put a ring in the barrel and finish the choke. Steel shot must be used in barrels marked: "For Steel Shot."

Bismuth shot is more expensive than lead and not as heavy, but is heavier than steel. It has the advantage of being usable in standard shotgun barrels without harming them.

When it comes to loading shotshells, the machines you will use have different systems from metallic ammunition loaders, and the sequence of steps will vary from one machine to another. As was pointed out in the chapter on loading equipment, shotshell loading is done on a single machine with a lot of attachments, while rifle and handgun ammunition is



There are some big differences between steel and lead shotshell components.

assembled using two or three bench-mounted tools with a number of attachments and several hand tools. Because of their relative complexity, shotshell reloading machines come with manuals that are clearly written and illustrated. They show you how to load shotshells on *that* machine. If you buy a used machine, be sure that the proper manual is with it and that the tool has all the necessary component parts. Failing this, you will have to write the company for a manual, or get someone who knows what he is doing to show you how to operate that particular machine. It is dangerous to attempt to load ammunition on a machine you don't know how to operate on an "I think I can figure this dude out" basis. Obsolete machines that may not have all their parts and manual are no bargain. Manufacturers such as Texan and Herters are out of business and spare parts, manuals and factory support are out of the question.

If you have never done any shotshell reloading it is probably best not to start with a progressive loader. These machines are the most complicated to use, and observing all the steps while determining whether or not they are being done correctly is difficult. Thus the beginner would do best starting with a basic single-stage loader such as the Lee Load-All 11 or MEC 600 Jr. Mark V. Unlike rifle and handgun loading where the manuals offer suggestions for working up loads to find an accurate one, shotshell loads are pretty much cut and dried. The manual that comes with the loader will instruct you on the use of the powder and shot bushings to be inserted in the charge bar of the machine. These must be matched to the proper type of powder and size of shot. They will dispense preset amounts of powder and shot. *Make sure you match these bushings and powders correctly!* Read the manual.

### Case Inspection

Even new and once-fired cases should be checked over for defects. Any with splits or serious defects in the case mouth or body, or splits in the metal head should be discarded. Cases should be segregated by maker as determined not only by the headstamp, but by the base wad configuration. Because they wear out sooner than rifle or handgun cases, and because worn cases give different velocities as the case mouths become softer, shotshells should be carefully identified by their intended loading as well as by maker and the number of times they have been reloaded. This means careful handling when shooting so you don't mix them up, and afterwards boxing or bagging them accordingly.

### Materials/Equipment Pre-Check

Make sure that your wads match the shells you are about to load. The loading manual will tell you which to buy. Select the proper primers, powder and proper size shot for your loads. Check that you have the correct bushing and shot bar in place for that combination of powder and shot, or have made the proper adjustments on the bar for those types that are adjustable. Fill the canisters on the machine. Lay out no more than 100 primers on the bench.



Shotcups/wads are designed for particular loads in specific shells. These wads hold 7/8-ounce of #7, #7 1/2, #8 or #9 shot. They are intended for use in the compression-formed plastic shells and are for target shooting.

### Case Resizing and Decapping

With machines such as the Lee, decapping and primer seating are done at the same location. With the MEC, primer seating is a separate step. Place the shell under the sizing die, or slip it into the die body, and pull the handle to the bottom of the stroke. This resizes and decaps the shell.

### Priming

A new primer is next placed on the primer seating station and the handle is pulled to bring the shell down onto the primer and seat it. This stroke must be firm, but not overly hard, in order to seat the primer flush with the shell head. Primers should be checked with a straightedge to assure proper seating.

## Powder Charging

The case is next moved to the station below the powder container. Depending on the exact configuration of the machine you are using, the handle is pulled to bring the case into contact with the powder/shot tube dispenser. The charge bar is then pushed across the bottom of the powder container (usually to the full left position) and the powder charge will be metered into the case. **Important:** This step should be verified by checking at least ten charges on a powder scale. If you do not use a scale you have no idea whether your charges are close—or even in the ballpark. If the machine is not delivering the proper amount of powder, within a tolerance of 5 percent of the listed charge, you may have to try another larger or smaller bushing in the charge bar, or the bushing may be clogged if the powder is not dry and free-flowing. This step should be done at the beginning of each loading session and when you change to a different lot of powder. Once it is determined the charge bar is dispensing powder as it should, move on to the next step.

## Wad Seating

This step may be done at the same station as powder charging or the shell may have to be moved to a new station. The wad is placed on the wad guide. The handle is pulled fully down and the wad is seated on the powder. Some powders are more sensitive to wad pressure than others, and will yield higher or lower velocities and pressures depending on their degree of compression. Red Dot is one of the more sensitive ones. The better machines have a pressure gauge on them. Note this and the wad seating height to determine that your wads are seated uniformly. If a wad goes far too deep, you have less than a full powder charge or no charge and you will have to recheck your charging operations. Care should be taken that the base cup on the wad is not caught and nicked or tipped by folds in the case mouth and descends straight onto the powder. If the seating pressure



Each shotshell load is component-specific. Primers, as well as all other components, are not created equal and should not be interchanged.

is too high you may have too much powder or an incorrect wad for that charge, or a wad not properly matched to that case. Wad seating pressure should be at least 20 pounds. Finally, check to see that the petals of the shotcup are in full contact with the case walls so they will not interfere with shot metering.

## Shot Metering

Depending on your machine, the shell may or may not be moved to another station for shot metering. Whatever, the shell is raised to the powder/shot charging tube and the charge bar is generally moved to the right across the bottom of the shot canister dropping the shot into the shell. It is important to have the proper shot bar for the load you are making. MEC tools (at least the older ones) have a different shot charge bar for each weight of shot. Other machines have adjustable shot bars or bars with powder insert bushings. Lee and Hornady machines have bushing inserts for both shot and powder.



The Lee Load-All II is an excellent entry-level shotshell loader at an affordable price. It can turn out an average of 100 rounds per hour, and loads lead or steel shot.



Various crimp styles, from left: an old-style rolled crimp on a paper shell with top wad; the rolled crimp, still used and necessary for making slug loads; typical six-point and eight-point crimps.



As with powder charging, shot charges must be checked on a scale to be sure they are accurate. The same five percent tolerance applies. Run several shot charges on your scale to verify that your machine is behaving properly. Occasionally a shot charge will jam or only partially

feed, and a visual inspection of each shell you load should be made. If the shot cup is not full, return the shell to the charging position and give the charging tube a tap or two. This should cause the remainder to drop and you can move to the next step.

The loading of buckshot is a special consideration, since shot this large cannot be metered through the machine. Buckshot is loaded by pellet *count*, not by weight, and the shot have to be counted and hand-fed into the shot cup. More importantly, buckshot must be nested in layers in the cup or they will not fit properly. Some of these loads call for "buffering" with a finely ground plastic material. This should be added with each layer and the case tapped with the finger to settle it into the cup until it is level with the top layer of shot. Needless to say, buckshot loads are best assembled on a single-stage press rather than on a progressive.

#### PELLET COUNT COMPARISON

Shot Size	12-Ga. 17/8 ozs. Lead pellets	Shot Size	12-Ga. 13/8 ozs. Steel pellets
6	422	4	263
4	253	2	172
2	163	BB	99
BB	94	T	71

#### SHOT SIZES

Shot Size	Diameter (Ins.)	No. of Pellets/Oz.	
		Lead	Steel
9	.08	585	—
8 1/2	.085	—	—
8	.09	411	—
7 1/2	.095	350	—
6	.11	225	316
5	.12	170	246
4	.13	135	191
3	.14	109	153
2	.15	87	125
1	.16	72	103
B	.17	59	84
BB	.18	50	72
BBB	.19	43	61
T	.20	36	52
F	.22	37	40

#### Crimp Starting

Shotshells have two forms of fold crimping: six-point and eight-point. The crimp starter should be matched to the fold pattern of the shells you are reloading. Never use a six-point crimp starter on an eight-point shell and vice versa. The crimp starter is adjustable and can be raised and lowered to vary the amount of crimp start. When working with various brands of shells, a certain amount of experimentation is needed to get the proper amount of crimp start. Remington and Federal shells seem to require a little less start than Activ and Winchester shells. If your finished shells show indentations in the crimped end of the shell, the crimp starter is set too deeply and will have to be backed off a bit.

(Text continued on page 138)

# Step-By-Step Reloading

## Shotshell Cartridges

(Photos courtesy Lee Precision, Inc.)

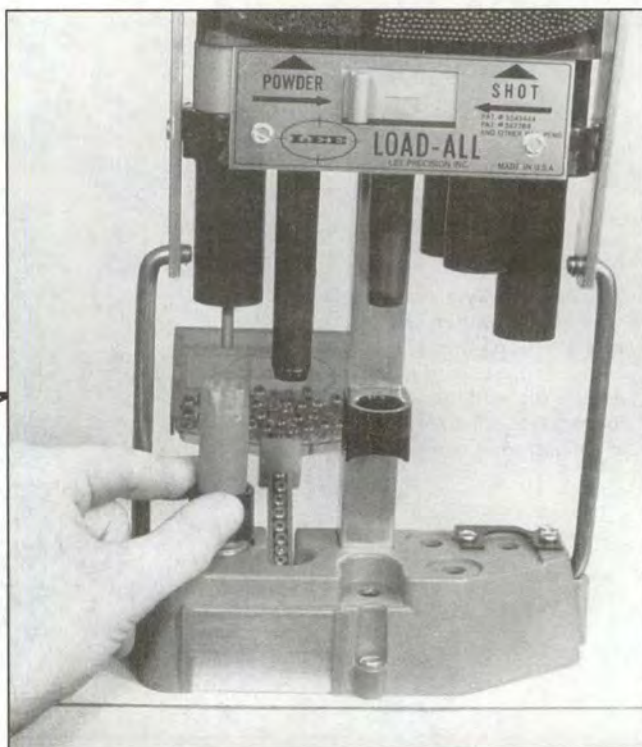

**Step 1 - Sizing:** Sort your hulls by brand and type, and discard the defective ones. Slip the sizing die, grooved end up, over the shell. Place the shell in Station 1 and pull down the handle. This full-length resizes and deprimers the shell.

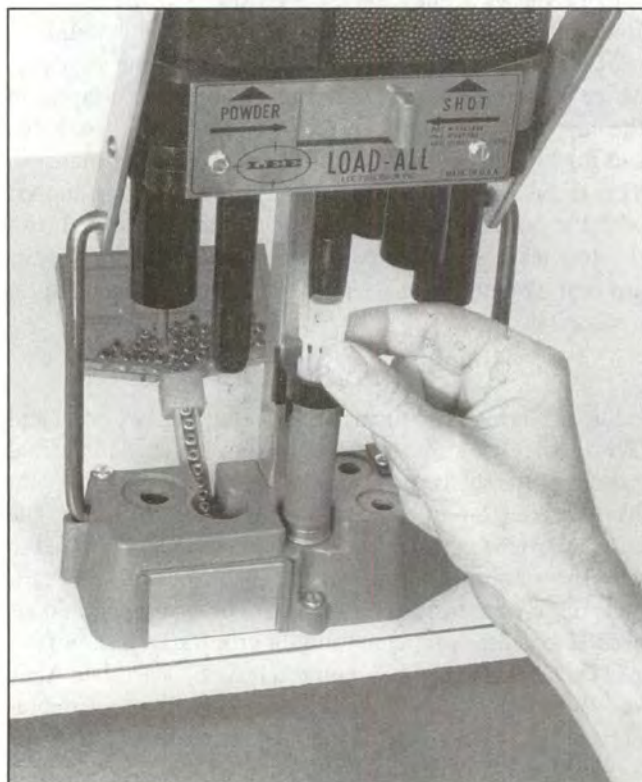

**Step 4 - Inserting the Wad:** Raise the handle, insert the proper wad and lower the press handle until it stops.

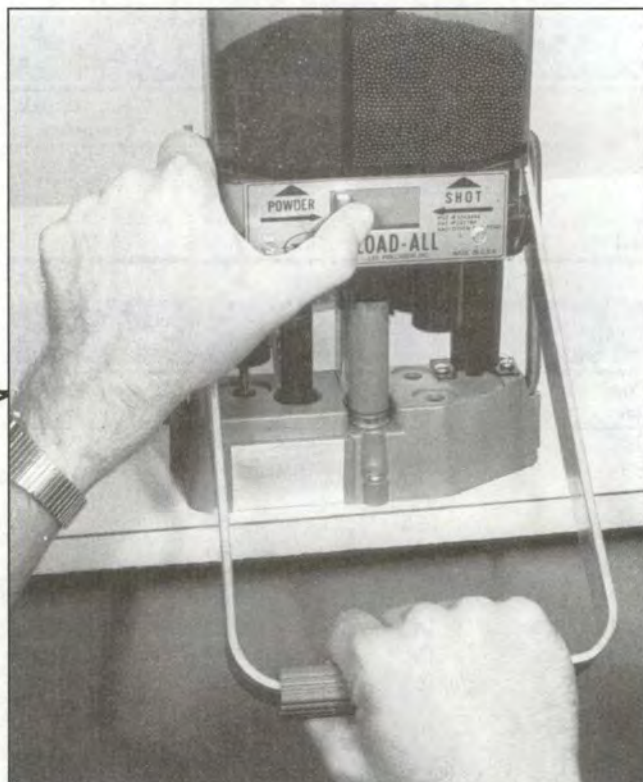

**Step 5 - Shot Charging:** Now slide the charge bar all the way to the left to add the shot. Raise the press handle.

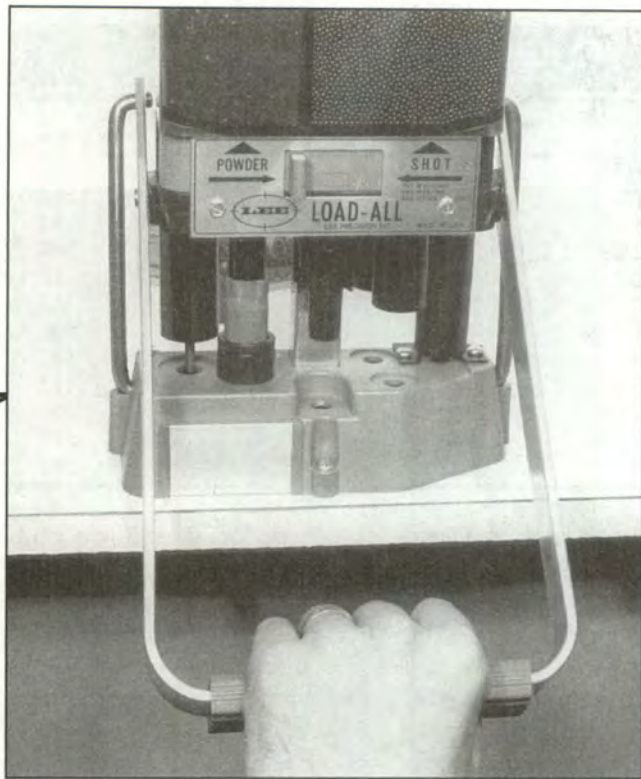

**Step 2 - Priming:** Place a primer in the priming pocket at Station 2. Move the shell onto Station 2 and pull down the handle. The sizing die will automatically be pushed off the shell at this station. Remove it completely.

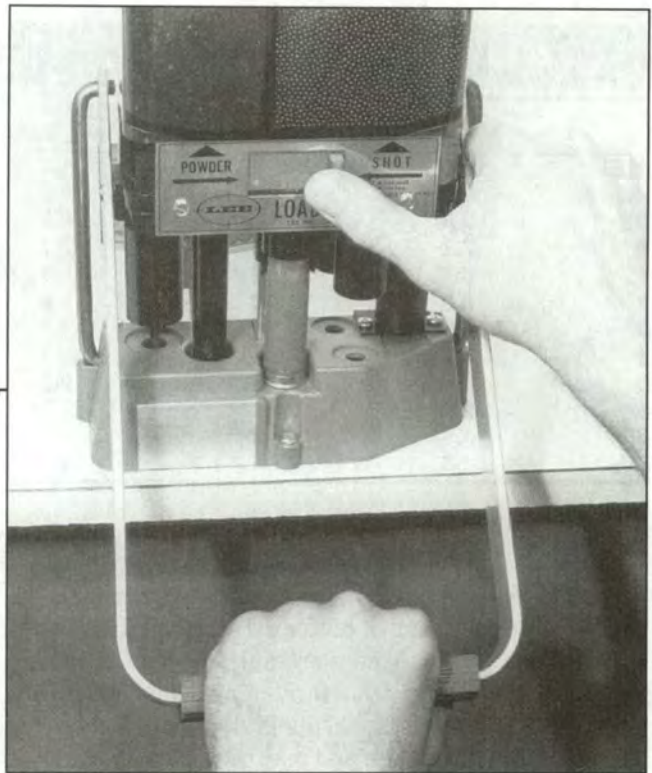

**Step 3 - Powder Charging:** Slip the shell into the wad guide at Station 3, lower the handle and slide the charge bar to the right to add the powder.

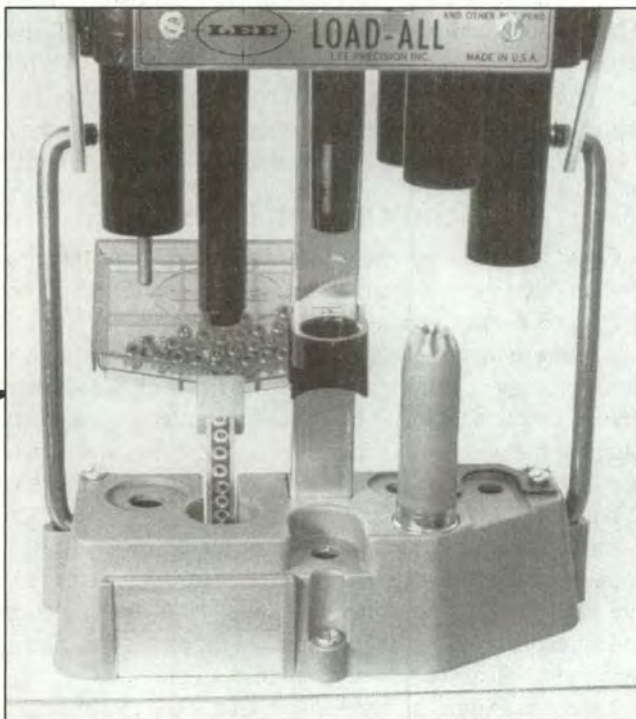

**Step 6 - Crimp Start:** Place the shell under the proper crimp starter, keeping an inward fold of the shell toward the front for proper alignment with the segmented starter. Pull the press handle down all the way, holding it there for about two seconds to set the plastic.

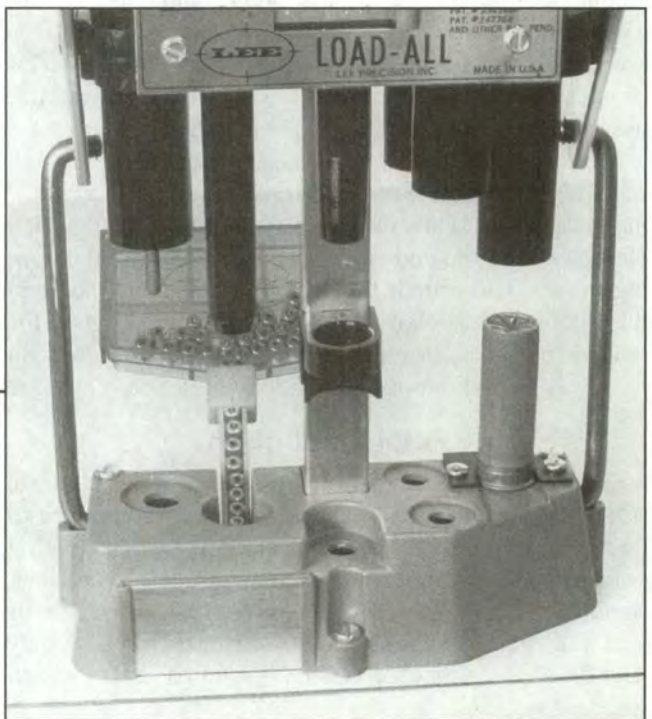

**Step 7 - Final Crimp:** Immediately move the shell into the shell-holder at Station 5, and pull the press handle down to complete the crimp. That completes the loading cycle, giving you a ready-to-shoot shotshell.

(Text continued from page 135)

### LEAD VERSUS STEEL PELLET WEIGHT

—Lead Pellet—		—Steel Pellet—	
Size	Wgt. Grs.	Size	Wgt. Grs.
BBB	10.4	F(TTT)	11.0
BB	8.8	TT	9.6
BB	8.8	T	8.3
B	7.3	BBB	7.1
1	6.1	BB	6.1
2	5.0	B	5.0
3	4.1	1	4.3
4	3.2	2	3.5
5	2.6	3	2.9
5	2.6	4	2.3
6	1.9	5	1.8
7 <sup>1/2</sup>	1.3	6	1.4

### STEEL VERSUS LEAD PELLET COUNT

—Steel Pellet—		—Lead Pellet—	
Size	No. Per oz.	Size	No. Per oz.
F(TTT)	39	T	34
TT	46	BBB	42
T	52	BB	50
BBB	62	B	60
BB	72	1	72
B	87	2	87
1	103	3	106
2	125	4	135
3	154	5	170
4	192	6	225
5	243	6	225
6	317	7	299

### Final Crimp

The shell is now placed on the final crimp station and the handle pulled down until it bottoms. Hold the handle in this position for a second to give the crimp a firm set, then raise the handle. If the crimp is not firmly closed, this step may be repeated. Crimp depth should duplicate the original factory load. This die is adjustable and may need some tinkering to get it to accommodate the make of case you are using.

Overall length of the finished shell is critical to feeding through magazines so die adjustment must be kept to a minimum. If the problem is the center of the shell being too high or too low, you can experiment with changing the wad for a longer or shorter one or adding or subtracting shot. Adding shot should be done with caution and not done with a maximum load. A 20-gauge card wad can be added to the bottom of the 12-gauge cup to act as a filler if needed. This should be done before the wad is seated. A supply of 1/8-inch and 1/16-inch card wads is a handy item to stock.

Most shotshell loading machines have a feature to put a slight taper on the case mouth to facilitate feeding in repeating guns. Some of the more expensive loaders such as the Hornady 366 Auto and Apex machines have a third crimping feature. This rounds the front of the shell and locks in the crimp with a slightly raised ring around the edge of the crimped end. This ensures the crimp will not open through jarring as it is fed through an autoloading action.

### Final Inspection

Since shotshells are made of plastic or paper and are softer than brass cartridges, it is always good practice to do a final size check before boxing them. Any case with a poor crimp that cannot be repaired in the approved manner should be junked. The same goes for one that has cracked or split in the reloading process. MEC's ring gauge is a handy item for a quick size check with a "go/no go" hole for each standard size shell.

### Ammunition Testing

Because shotguns deliver a pattern of shot that is determined primarily by the choke of the barrel, testing mainly

depends on duplicating factory performance. Light loads will obviously put fewer shot in the standard 30-inch circle at 40 yards than heavier loads. To check the patterning of your gun, you need a 40-yard range and a large piece of paper at least one square yard in size. Shoot one shot at the center of the target. Draw a 30-inch circle around the densest area and count the holes. Various loading manuals will give you the number of shot per ounce, so you can figure the percentage or you can make an actual count. Beyond this there are some other observations you can make. One is to see where the greatest area of density lies. It should be in the center of your point of aim and not biased to the side. The shot pattern should be more or less even within the circle. Some guns have a tendency to produce a very dense center with an uneven dispersal of hits at the edge of the circle. This may mean missed clays or crippled game. To check the efficacy of your pattern; cut a clay target-size circle (4 5/16-inch) out of a piece of clear plastic and move it around the pattern. Areas with fewer than three pellets in them are in the doubtful zone in terms of an assured kill on most birds.

### Good and Bad Loads

Good loads are the ones that do what you want them to do and often the bad load is one that does not. This may be because it is inappropriate to the situation—too small shot, too light a load, not enough pattern density. These problems are rooted mainly in the lack of knowledge of the shooter and in taking shots that he should not attempt and then blaming the gun or the ammunition. There are, however, a few false notions and a similar number of home truths that should be addressed.

Larger-bore guns kick more than smaller ones with the same loading. Not true. The recoil is mostly determined by the weight of the shot charge and its velocity. The difference in felt recoil will be affected by the weight of the gun, and a heavy gun will absorb more recoil than a light one.

Larger-bore guns hit harder. Not true. The velocity of all shotgun loads is nearly the same—in the 1200-1500 fps range. A #6 pellet from a .410 is flying as fast and hitting as hard as one moving at the same velocity from a 10-gauge, even though the .410 makes less noise.



Homady's 366 Auto machine is for shotgunners who do a lot of shooting. It has a high production rate and is built of high-quality materials.



The MEC 600 Jr. Mark V can turn out an average of 200 rounds per hour. It's available in 10, 12, 16, 20 and 28 gauges.

The same shot charge from a 20-gauge and a 12-gauge are equally effective. This tends not to be the case. Longer shot columns tend to result in greater compression (distortion of the pellets at the back of the load) and thus produce more fliers, and consequently a less dense pattern. This probably is what led to the notion of larger-bore guns "hitting harder."

Harder shot hits harder. Not really, but hard and extra-hard shot deliver more pellets to the central pattern with fewer fliers. Heavy loads, particularly in the .410 and 3-inch 20-gauge shells, and the 3 1/2-inch 12-gauge magnum, with their longer shot column, are most effective with hard shot.

Certain powders do not perform well at sub-freezing temperatures. This seems to be true, according to the folks at Ballistic Products. They ran tests on powder performance and concluded that Blue Dot gave significantly lower velocities at low temperatures, much more so than other powders. However, all velocities will be lower in cold conditions when the air is denser.

High-velocity shotshell loads have some fans who believe that by pumping the velocity up to 1500 fps there is some-

thing to be gained by getting the shot to the target faster. More pressure and more recoil top the list unless the shot charge is reduced. At the velocity top end, patterns get pretty ragged. Around 1400 fps, however, patterns hold well and at ranges of 25 to 30 yards are quite lethal. Unfortunately, this added lethality is at the price of ruining game meat. This is a plus in the varmint-shooting area, not so good for pot hunting. Do these loads really "reach out there and get 'em?" Not really, since pellets are very poor performers in the aerodynamic sense. The initial gain in velocity is soon shed, and at 45-plus yards this hot-rod load is not going to perform much differently than the standard factory loading. If the velocity is achieved at a reduction in the amount of shot, the situation is a little worse because of a lower-density pattern.

The main advantage of such hot loadings would appear to be in trap and Skeet shooting, where the targets are at relatively close range. Hard hitting assures more breakage and higher velocities cut lead calculation in these games of hitting them fast and hard.

Reloading involves a number of processes before the trigger is tripped, but once the powder starts burning, it's all about ballistics.

# A Basic Knowledge of Ballistics

“SEND THAT GUN down to ballistics,” is a throwaway line from dozens of forgettable TV cop shows. This notion of ballistics being what police crime labs do, is ingrained in the minds of an astonishing number of people.

James Hamby, now head of the Indianapolis crime lab, tells of a court appearance that illustrates this point quite well. After a lengthy introduction, with explanations of his firearms examiner position, the old judge looked hard at Hamby and said, “Yeah, but what about ballistics?” It took Hamby a while to explain that “ballistics” was only a small part of the criminal investigation process, and that as an examiner he matches crime and test bullets and shell casings with particular guns, which is called “firearms examination” and has *nothing* to do with ballistics.

Calvin Goddard, the father of the field of firearms examination, later admitted that he rued the day he came up with the term “forensic ballistics.” This was a hastily conceived name for the emerging science of “firearms examination” which, unfortunately, stuck in the public mind. As of

this day, there is only one police organization in the country that still refers to its firearms section as "The Ballistics Lab"—the NYPD.

Ballistics, *real* ballistics, is the scientific investigation of the behavior of projectiles in flight. The name is derived from an ancient Roman siege machine called a *ballista*, a kind of king-size crossbow that launched spears, rocks and whatnot. The field of ballistics, in the modern sense, deals primarily with projectiles fired from guns, and is further divided into three subsections: interior ballistics, exterior ballistics and terminal ballistics. Ballistics spreads over a number of scientific fields, encompassing physics (including Newton's laws of motion), mechanics, dynamic forces, aerodynamics and the forces of air. It links up with chemistry, mathematics (including calculus), meteorology, metallurgy and medicine.

### Interior Ballistics

Interior ballistics deals with everything that happens from the beginning of the firing sequence to the point where the projectile exits the barrel of the gun. The first serious use of guns was at the Battle of Crecy, in 1346, in which the English forces employed small cannons against the French. This event initiated the consideration of problems of interior ballistics—questions of pressure and velocity and pressure and gun failure—discussed in Chapter 3. It led to the investigation of propellants and ignition systems and considerations of gun barrel material and manufacture, which eventually led to the creation of the field of metallurgy. The basic questions were: how much pressure can be generated in a gun barrel and have it hold together, and how fast will a projectile be ejected? Rodman in the U.S. and Nobel in Great Britain developed the first reliable systems of pressure measurement.

Beyond the problem of establishing safe means of measuring internal pressures are considerations of increasing velocity without increasing pressure proportionally. There is the assessment of the best materials for making these projectiles, their shape, weight, strength and design, to see that they do not come apart in flight and either expand or penetrate or do some desired combination of both on reaching the target. There is the matter of material for gun barrels, the problems of barrel strength and wear. Suddenly the field of economics raises its dismal head as cost is pitted against longevity and efficiency.

Since a gun is an internal combustion, pressure-driven engine, it depends on gases from burning gunpowder to overcome the inertia of the projectile. Considerable pressure builds up (up to 6000 psi in some instances) before the inertial force of the weight of the projectile is overcome and it starts to move. The action of swaging the projectile into the rifling causes pressure to increase to the point where the peak pressure is reached. Once the swaged projectile is in motion, pressure begins to drop as the speed of the projectile picks up and the space behind it increases in volume. When the projectile is out of the barrel, pressure drops rapidly to that of the surrounding atmosphere.

Propellant materials are a major concern under the rubric of interior ballistics. These include priming materials that will burn in such a way as to provide the best possible ignition, propellants that will produce a pressure curve best suited to a particular length of barrel, and both to be of material that will work reliably under a variety of temperature conditions and not change their burning characteristics over time.

These questions and concerns have occupied ballisticians for the past 600-plus years and not all the problems have been solved yet. The 20th century probably saw the end of the evolution of guns (firearms) as we know them, and the 21st may see the practical development of electromagnetic "rail guns" capable of launching projectiles at half-again to twice, to who knows how much, greater velocity than that achieved with conventional firearms. When this comes to pass, it will probably end investigations in interior ballistics, since with rail guns, there is no interior—the projectile is launched by electromagnetic propulsive forces generated by twin rods between which the bullet travels (starting from a flat "launch pad") through the air.

### Exterior Ballistics

Exterior ballistics is concerned with hitting the target with accuracy, which means achieving consistency of bullet behavior. It encompasses the study of everything that affects a bullet's flight from the moment it exits the barrel until it reaches the target. The line between interior ballistics and exterior ballistics is blurred since, from the start, the bullet is pushing air within the gun barrel, and for a short distance the muzzle blast continues the acceleration process, often causing the bullet to yaw a bit in flight until rotation stabilizes it. Things happening within the gun barrel have a great deal to do with how a projectile will behave once it has exited that barrel.

Ballistics as a science had its beginning with the publication of Nicholas Tartaglia's treatise on the flight of projectiles, published in 1537. Tartaglia was the first to calculate trajectories and to theorize that maximum range was achieved at an exit angle of 45 degrees. He was wrong in this, but correct in assuming that all trajectories were curved.

The velocity of a projectile was first measured in 1741 by Benjamin Robins, inventor of the ballistic pendulum. He fired projectiles of known weight into the weight of a pendulum, also of known weight, and measured the distance of the swing. Robbins was the first investigator to come up with a system for reasonably accurate velocity measurement to 1700 fps. Using the same pendulum, Hutton in England was the first to note that air resistance had a considerable influence on reducing velocity, and that projectiles lost velocity in direct proportion to their speed—that the higher the initial velocity, the more rapid the decline in velocity.

By the 1840s the ballistic pendulum became obsolete with Wheatstone's proposal to measure bullet flight through time as it passed through screens breaking electrical contacts. The Le Boulenger chronograph using such a system was in use in

the 1860s to the 1930s, when the first all-electronic machines using photoelectric screens were perfected.

The trajectory of a bullet is the curved path it takes from the gun muzzle to the target. The basic force affecting this curve (for small arms) is gravity. Temperature, which affects air density, is a second factor. In a vacuum, the trajectory of a bullet would be affected only by gravity, and it would thus describe a flight path that would be parabolic with the angle of descent being the same as the angle of ascent. Air resistance, however, reduces velocity and thus produces a much steeper angle of descent. As this force slows the bullet and its forward velocity declines, the force of gravity predominates and the path of the bullet becomes less horizontal and more vertical.

The ballistic coefficient is a major factor in the calculation of the trajectory of a bullet. This figure is derived from the weight, diameter and form. Form is the degree of streamlining based on an ideal shape of a needle nose tapering back to a rounded body and then to a tapered base. Bullets of this "boattail" design have a high ballistic coefficient and will fly much farther than a flat-nosed wadcutter, which is nearly a perfect cylinder.

Air temperature will have a marked effect on bullet trajectory. Hot air is less dense, because the molecules are farther apart, and will offer less resistance than cold air, wherein they are closer together. A rifle zeroed on a summer day at a temperature of 80 degrees Fahrenheit will shoot low on a winter day with a temperature of 10 degrees.

Moving air (wind) serves to accelerate or decelerate the forward motion of the bullet to a degree and will affect where it strikes. Head winds will decelerate velocity and lower the point of impact. Tail winds will accelerate velocity and raise the point of impact, all other things being equal.

Lateral bullet displacement. No one knows who discovered that spin-stabilizing projectiles made a tremendous increase in their accuracy. This permitted the development of highly efficient aerodynamic designs that would fly farther, lose velocity less quickly and retain more energy than a round ball. Arms with barrels containing helical grooves (rifling) first appeared in the late 1500s. While spin-stabilized projectiles fly far straighter than round balls, the rotation is affected by the air, and irregularities on the bullet's surface, caused primarily by the rifling, allow the bullet to work against the air causing it to roll or drift in flight in the

direction it is spinning. Lt. Col. A.R. Buffington, U.S.A., developed a sight for the Springfield rifle, in 1883, which contained an automatic compensation feature for this rotational drift.

Crosswinds will have a decided effect on the lateral displacement of a bullet. The greatest displacement is when the wind is blowing at a right angle to the bullet's flight path. Wind velocity affects drift in proportion to the speed of the wind. Bullet velocity also affects the amount of drift, with the greatest degree of drift occurring when the bullet is moving at or slightly above the speed of sound. Above and below this point, wind drift is somewhat less. A bullet traveling above the speed of sound sets up a shock wave, which indicates a loss of kinetic energy caused by drag. The degree of drag is dependent on bullet diameter, velocity, air density, and the drag coefficient, which is figured from such factors as projectile shape, air density, yaw and Mach number—the ratio of the projectile velocity to the speed of sound.

Other factors affecting lateral displacement are ricochets and deflections. Ricochets are the result of bullets striking hard ground, ice, pavement or water at a shallow angle. When this occurs the bullet nearly always loses its rotational stability and tumbles in flight. Even when striking water, which most consider an easily penetrated substance, bullets will ricochet if they strike below a critical angle of entry of 5.75 degrees. Bullets striking at angles above 2 degrees will lose their rotational stability.

Deflection might be termed a lateral ricochet. For many years there have been questions raised regarding "brush busting", the ability of a bullet to hit a small branch and keep going (more or less) straight to the target. Debate over this issue had been fueled by stories of stellar performances by particular bullets which had penetrated small branches, often cutting them off in the process, then felled a game animal some distance away. There were perhaps a greater number of stories of the opposite happening, where a bullet clipped a twig and went spinning out of control, missing a large target entirely. Some investigations into deflections found support for both claims. The critical factors were the angle of contact of the bullet and the branch, and whether the bullet was damaged by the branch. If the bullet struck the branch dead center and was undamaged, it continued on a relatively straight path. If it was damaged it lost stability. If it struck to one side of dead center it would deflect and usually lose stability and tumble. The greatest degree of deflection was at the point where *half* the bullet was in contact with the branch. The degree of deflection decreased as the point of contact moved closer to dead center or toward the edge resulting in a slight grazing of the branch.

## Terminal Ballistics

Terminal ballistics involves everything that happens to a bullet from the moment it reaches the target to the point where all motion ceases. The term means different things to different people. For the target shooter, punching paper or knocking over metal silhouettes is all that matters. The



Exterior ballistics involves all that happens to the bullet from muzzle to target. Here's a Remington Accelerator leaving the muzzle at 4080 fps, and the sabot and bullet 18 inches downrange.



big game hunter is concerned with the ability of a bullet to both penetrate into a vital area, and expand, creating a large wound channel and quick incapacitation. The varmint hunter wants quick expansion on relatively thin-skinned animals to create a large wound cavity and instant death. The small game hunter needs something between these two extremes—bullets that will expand, killing quickly, but not causing the kind of disruption encountered in the varmint bullet that destroys a great deal of edible meat. For military ends, terminal ballistics includes penetration of concrete, building materials, armor plate and starting fires in fuel tanks.

Wound ballistics is a subset of terminal ballistics and is concerned with the medical aspects of gunshot wounds, including wound trauma incapacitation and treatment of gunshot wounds.

Improvements in terminal ballistics have not been as fast as those in interior and exterior ballistics, and have come about with the development of high-speed cinematography and high-speed radiography. Development of ballistic gelatin as a tissue substitute has been a particular aid to improved terminal ballistics. In the last several years considerable advancements have been made in developing bullets that will produce controlled expansion. This allows them to penetrate while expanding at a rate that will not result in breakup or in over-expansion and inadequate penetration.

A great deal has been written regarding the role of velocity, that is to say high velocity, in the area of terminal and wound ballistics. According to Dr. Martin Fackler, the leading wound ballistics expert in the country, bullet lethality is an easily understood concept. Lethality is determined by answering two questions: How big is the hole it produces? How deep is this hole? Bigger and deeper holes are more likely to intersect with vital organs, cause greater loss of blood, and result in death.

What about high velocity? In the 1960s, reports of horrendous wounds created by the M-16 rifle and, to a lesser degree, the AK-47 rifle used in Vietnam began pouring in. The wounding effects, while genuine, were presented by an ignorant press as being wholly an artifact of high velocity. As often happens, misinformation and half-truths become pillars of public opinion as they receive amplification by politicians and other public figures through the media, without scrutiny from the researcher. In the case of the velocity/lethality controversy, there is some truth to the wounding effects of hydrostatic or hydraulic shock of a high velocity bullet when it contacts an area of a body such as the liver or cranial vault. Liver tissue has poor elasticity and brain tissue behaves like a semi-fluid in a sealed container. Anyone who has seen the effect of a 3000 fps bullet on a closed container of water has a good idea of the pressure-wave effect it produces. But, this does not apply to other types of tissue with a higher degree of elasticity. While a large, instantaneous cavity is created, the resultant tissue damage of a permanent sort is minimal, not extending far beyond the path of the bullet.

In the case of extreme hyper-velocity impacts—3500-

4000+ fps—both the bullet and target behave in the manner of fluids regardless of the material they are made of. This allows a 48-grain copper-jacketed bullet with an exposed lead point to knock a hole through a half-inch of steel armor plate. At less than these velocities, the softer bullet would simply splatter on the surface of the harder material.

Bullet design had more to do with terminal/wound ballistics than other factors. For the first 400 years of their existence, bullets were made of lead. The creation of the jacketed bullet in the late 19th century came as a result of the development of smokeless powder and the quest for flat trajectories, meaning higher velocities. While flatter shooting was achieved, the lethality of the small, round-nose bullets was far less than with large, soft, lead bullets of the 45-70 class. In their efforts to achieve still flatter trajectories, the Germans found that their spitzer (pointed) bullet, in addition to possessing less drag than the round-nose bullet, created a more severe wound. This design, with its long tapering point, had a heavy end and a light end and when the bullet lost stability by striking a body, the heavy rear would flip over the front causing the bullet to make a larger hole—often exiting base first as it tumbled. Soon, nearly everyone was using the spitzer bullet. The flip-over was improved by the British who filled the pointed end with aluminum and the rear with lead. Later, the Russians simply left an air cavity in the front.

The Vietnam era saw the latest improvement in the spitzer bullet that gave it much the same effect as an expanding type. By the simple expedient of increasing velocity, as in the case of the 7.62x39mm AK-47 bullet and the 223 (5.56x45mm) M-16 bullet, greater instability on impact was achieved. The 55-grain M-16 bullet, with a muzzle velocity of over 3000 fps, would often break in half at the cannelure in the middle and the two halves would shred in the body, creating a more massive wound. Even more deadly was the 7.62x51mm (308) NATO bullet made by the West German government that featured a very thin steel jacket. It was 50 percent thinner than the U.S. version and would shred in a body, causing an even more massive wound by virtue of its greater size and weight. Velocity was critical to achieving these effects, but did not cause them. Once velocity dropped below 2500 fps, lethality decreased to handgun level with equivalent-caliber jacketed bullets.

Designs for hunting bullets did not have to work under the constraints placed on nations by The Hague and Geneva conventions, which attempted to create “rules” of warfare. Hunting bullets are intended for killing, as opposed to creating casualties in war, thus they can be made of a more lethal design; i.e. to expand in a controlled manner at predetermined velocities.

Have we gone about as far as we can go along this line of development? In terms of bullet design, we probably have. In terms of making firearms capable of handling more powerful ammunition, making this ammunition more reliable and accurate, and making both more compact, there are still some worlds to be conquered.

No single book can supply all of the available knowledge on the subject of reloading, so here's where you can find whatever you want or need to know.

# Sources and Resources

**THE MOST DIRECT** route to current information on reloading tools, accessories, supplies and reloading data is ask the manufacturers themselves, who are more than eager to provide any information you want. The major manufacturers in the reloading industry are members of the National Reloading Manufacturers Association (NRMA), although there are many, many more companies, mail-order houses and retailers who offer their own catalogs, data books and the like. For starters, the following list of NRMA members will provide information that is available now and how to get it.

**ACCURATE ARMS COMPANY, INC.**

5891 Highway 230 West  
McEwen, TN 37101  
(931) 729-4207

e-mail: tech@accuratecompanies.com

Smokeless Powders for Reloading

- Reloading Data Booklet -- No Charge
- Accurate Reloading Manual Number 2 \$16.95

**ALLIANT POWDER**

P.O. Box 6 Rt. 114  
Radford, VA 24143-0096  
(540) 639-8503

e-mail: alliant\_reloading@atk.com

Smokeless Powder Group

- Reloaders' Guide for Smokeless Powders -- No Charge

**BARNES BULLETS, INC.**

P.O. Box 215  
American Fork, UT 84003  
(800) 574-9200 or  
(801) 756-4222  
(801) 756-2465 fax

e-mail address: email@barnesbullets.com

Bullets for Reloading-Rifle, Pistol, Muzzleloading, Shotgun

Slugs, Accessories and Ballistics Software

- Annual Products Catalog -- No Charge
- 2nd Edition Reloading Manual \$24.99
- Computer Ballistic Program \$49.95 (available for download at www.barnesbullets.com)

**CCI SPEER**

P.O. Box 856  
Lewiston, ID 83501

Phone:

(Technical Service) 800-627-3640

(Purchases) 800-533-5000

Primers, bullets, ammunition

- Complete Product Catalog -- No Charge
- Speer Manual #13 #17.95 (call 800-533-5000)

**CLYMER MFG. CO.**

1645 West Hamlin Road  
Rochester Hills, MI 48309-3312  
(248) 853-5555  
(248) 853-1530 fax

e-mail: clymer@clymertool.com

Guns tools, including reamers and headspace gauges

- Complete Product Catalog \$5 Refundable
- Price List -- No Charge

**DILLON PRECISION PRODUCTS, INC.**

8009 E. Dillon's Way  
Scottsdale, AZ 85260  
(602) 948-8009

e-mail address: dillon@dillonprecision.com

Reloading Equipment, Accessories and Components

- Blue Press Magazine/Catalog -- No Charge

**FEDERAL CARTRIDGE COMPANY**

900 Ehlen Drive  
Anoka, MN 55303-7503  
(800) 322-2342

Sporting Ammunition and Components

- Annual Products Catalogs -- No Charge
- Shotgun Loading Data Brochure -- No Charge

**HODGDON POWDER COMPANY, INC.**

6231 Robinson  
Shawnee Mission, KS 66202  
(913) 362-9455

e-mail address: info@hodgdon.com

Smokeless Powders and Accessories, Pyrodex®

- Basic Loading Data Manual -- No Charge
- Reloading Data Manual #26 includes rifle, pistol, shotgun and Pyrodex® data \$19.95
- Pyrodex® Brochure and Data -- No Charge
- Shotgun Data Manual, 1st Edition \$19.95
- Blast Program, Electronic Data Manual \$49.95

**HORNADY MANUFACTURING**

P.O. Box 1848  
Grand Island, NE 68802  
(308) 382-1390

e-mail address: webmaster@hornady.com

Rifle and Pistol Bullets Reloading Tools and Accessories

- Annual Products Catalog \$2.00
- Bullet and Cartridge Poster No Charge
- Retail Price List -- No Charge
- Hornady Reloading Manual \$49.95
- XTP Brochure -- No Charge
- Light Magnum Flyer -- No Charge
- Hornady Load Notes \$5.00 each

**IMR POWDER COMPANY**

(Now a part of Hodgdon Powder Co. Contact Hodgdon for:

- IMR Handloaders' Guide -- No Charge

**KALTRON-PETTIBONE**

1241 Ellis Street  
Bensenville, IL 60106  
(800) 683-0464

e-mail address: kaltron@concentric.net

Importer of Vihtavuori Smokeless Powders and Lapua ammunition and components

- Reloading Guide, 48p. -- No Charge
- Vihtavuori Reloading Manual
- Lapua Shooting and Reloading Manual

**LEE PRECISION INC.**

4275 Highway U  
Hartford, WI 53027  
262-673-3075 Voice

262-673-9273 FAX

Another major reloading company to contact for product and reloading data:

**LYMAN PRODUCTS CORPORATION**

475 Smith Street  
Middletown, CT 06457  
(860) 632-2020

e-mail address: lyman@cshore.com

Case Cleaning and Preparation Systems, Reloading Tools, Bullet Casting, Black Powder Products, Metallic Sights, Shotgun Chokes, Compensators and Targ-Dots

- Annual Products Catalog -- No Charge
- Big Game Cartridges & Rifles \$19.95
- 47th Reloading Handbook \$23.95
- Shotgun Handbook (4th Edition) \$24.95
- Cast Bullet Handbook \$19.95
- Pistol & Revolver Handbook (2nd Edition) \$19.95
- Metallic Reloading User's Guide \$1.95

**MEC (MAYVILLE ENGINEERING CO.)**

715 South Street  
Mayville, WI 53050  
(920) 387-4500, ext. 6449

e-mail address: reloaders@mayvl.com

Reloading Tools and Accessories

- Product Catalog No Charge
- Bushing Chart No Charge
- "How to Reload Shotshells" -- No Charge

**MTM MOLDED PRODUCTS**

3370 Obco Court  
Dayton, OH 45414  
(937) 890-7376

(937) 890-1747 fax

e-mail address: mtmmail@cs.com

Plastic Ammo Boxes, Loading Trays, Funnels, etc.

- Annual Products Catalog -- No Charge
- Reloading Manual No. 2 \$9.90

**NOSLER, INC.**

P.O. Box 671  
Bend, OR 97709  
(800) 888-3921

Rifle, Handgun and Muzzleloading Bullets

- Annual Bullet Catalog -- No Charge
- Reloading Guide #5 \$24.95

**PRECISION RELOADING, INC.**

PO Box 122  
Stafford Springs, CT 06076

Catalog Requests & Orders Only 1-800-223-0900

Technical Support & Customer Service

1-860-684-5680

e-mail address: info@precisionreloading.com

Shotgun, Rifle & Pistol Reloading Equipment,

Components & Supplies, Lead, Bismuth &

Steel Shot Reloading Components

- Annual Products Catalog -- No Charge
- Bismuth Shot Manual \$5.95
- Steel Shot Manual \$5.95
- NEW "Blanks to Supersonics" Reloading Manual \$8.95

**RCBS**

605 Oro Dam Blvd.  
Oroville, Ca 95965  
(800) 533-5000

Reloading Tools and Accessories

- Complete Product Catalog -- No Charge
- A Beginner's Guide to Handloading -- No Charge

**REMINGTON ARMS CO., INC.**

Consumer Information  
870 Remington Drive  
Madison, NC 27025-0700  
(502) 548-8700

Reloading Components

- Annual Products Catalog -- No Charge
- Safety Booklet -- No Charge

**SIERRA BULLETS**

1400 West Henry  
P.O. Box 818

Sedalia, MO 65302-0818

(800) 223-8799 for Technical Information

(888) 223-3006 for all other calls

(660) 827-6300

(660) 827-4999 fax

e-mail address: sierra@sierrabullets.com

Jacketed Rifle and Handgun Bullets, Reloading Manuals, Reloading Videos, Exterior Ballistic Computer Software programs, Imprinted Apparel.

- Annual Product Catalog -- No Charge
- Quarterly Ballistic Newsletter -- No Charge
- 5th Edition Rifle & Handgun Reloading Manual \$28.95
- Sierra INFINITY 5.0 Exterior Ballistic Computer Program on CD Rom \$39.95
- Sierra INFINITY Suite 5.0 & 5th Edition Manuals on CD Rom \$59.95
- Introduction to Rifle Reloading Video (VHS) \$29.95
- Introduction to Rifle Reloading Video (DVD) \$32.95
- Introduction to Handgun Reloading Video (VHS) \$29.95
- Introduction to Handgun Reloading Video (DVD) \$32.95
- Advanced Hi-Power Rifle Reloading Video (VHS) \$39.95
- Advanced Hi-Power Rifle Reloading Video (DVD) \$42.95
- 50th Anniversary Commemorative Bullet Board (limited) \$199.95

**STARLINE, INC.**

1300 West Henry Street  
Sedalia, MO 65301  
(660) 827-6640

e-mail address: bhayden@starlinebrass.com

"Makers of the Finest Handgun Brass"

Online Ordering Available

**SWIFT BULLET COMPANY**

201 Main Street, P.O. Box 27  
Quinter, KS 67752  
(785) 754-3959

A-Frame™, Scirroco™ and Muzzleloader Bullets

- Flyers & Brochures -- No Charge

**WINCHESTER GROUP, OLIN CORPORATION**

427 N. Shamrock  
East Alton, IL 62024  
(618) 258-2204

Ammunition and Components

- Ball Powder Propellant Reloading Manual -- No Charge
- Ammunition Guide -- No Charge

**ASSOCIATE MEMBERS****KP/DBI BOOKS, INC.**

700 E. State Street  
Iola, WI 54990-0001

Special publications for the shooter and reloader including Handloader's Digest, which includes a very complete "Handloader's Library."

**Handloader Magazine**

6471 Airport Dr.  
Prescott, AZ 86301

e-mail address: info@handloadermagazine.com

(Also several special reloading publications)

**MidwayUSA**

5875 W. Van Horn Tavern Rd.  
Columbia, MO 65203

Email: CustomerService@MidwayUSA.com

Phone: 1-800-243-3220

Fax: 1-800-992-8312

Major manufacturer, mail order and online provider of shooting and reloading products.

**National Shooting Sports Foundation**

Flintlock Ridge Office Center  
11 Mile Hill Road  
Newtown, CT 06470-2359  
(203) 426-1320

**SAAMI**

P.O. Box 262  
Frankfort, NY 13340-0262  
(203) 426-1320

## The Internet

As in all walks of life, you can find more information on the World Wide Web than you could possibly use or absorb in several lifetimes. If you search for "reloading" on the Yahoo search engine, they serve up more than a million websites relating to reloading. Lycos offers 874,000 sites, Google 605,000. If you search for "ballistics," Lycos delivers 356,000 websites. OK, narrow it down to "ammunition primers" and you only get 50,000 sites, although "primer pocket" will offer 350,000. "Smokeless powder" gets you only 42,000. Be as general as you wish, or as specific as you wish, you can surf your way to information unlimited. A good place to start is the NRMA's site. [www.reload-nrma.com](http://www.reload-nrma.com) It will link you to many other sites, and you're on your way.

## Reference Books

C.Rodney James, the editor of the 6th Edition of *The ABCs of Reloading*, has researched reference material for more than 40 years and offered what he considered to be the best:

"The bibliography and source references that follow are a gleaning of some 40 years of study and experience. It is both spotty and idiosyncratic, but contains those books and sources found to be worth the money and/or effort.," James noted.

## Ballistics

*The Bullet's Flight From Powder to Target*, by Dr. Franklin W. Mann, MD. Originally published in 1909, various reprints. This is the first real book on ballistics. Even today, some 95 years after it was first published, this book contains useful information regarding bullet behavior under an astonishing number of conditions. Mann was more of a tinkerer than a scientist, but was one of those dedicated souls who set out in pursuit of that eternal quest of getting all the bullets in one hole. His experiments were often predicated on the notion of: "I wonder what would happen if...?" The good doctor had enough money to buy a lot of rifles and replacement barrels. His work with cast, lead-alloy bullets is probably second to none. His book probably raises as many questions as it answers. The second volume might have provided these answers had the manuscript not been destroyed.

*Understanding Ballistics 2nd Ed*, by Robert A. Rinker, Mulberry House, P.O. Box 575, Corydon, IN 47112, 1996. 373 pp. Paper covers. \$19.95.

In spite of the occasional sentence that isn't a sentence, this book does an excellent job of explaining the scientific aspects of ballistics. It goes from the basic to the advanced level while keeping the math to a minimum and the explanations clear. A good glossary of ballistic terms is included.

*Bullet Penetration*, by Duncan McPherson, Ballistic Publications, Box 772, El Segundo, CA, 90245, 1994. 303 pp. \$39.95.

This book deals exclusively with terminal ballistics with handgun ammunition. Anyone interested in stopping power, shocking power and all that, should forget anything you ever read on the subject except perhaps Julian Hatcher. McPherson, an engineer and one of the charter members of the International Wound Ballistics Association, has analyzed and scrutinized everyone's work in this area before conducting his very thorough research. The result has cleared away a number of cherished myths regarding bullet performance and the measurement of same. Though technical in nature, this work is very accessible to those without a mathematics background.

*Wound Ballistics Review*, edited by Dr. Martin L. Fackler, MD. Published twice a year by the International Wound Ballistics Association, P.O. Box 701 El Segundo, CA 90245-701. Four issues \$40.00.

The IWBA is devoted to the medical and technical study of wound ballistics, including evaluation of literature in the field as well as encouraging and promoting new work. IWBA is an organization of medical, technical and law enforcement professionals devoted to hard research, truth telling and correction of misinformation regarding firearms, bullets, and their effects. Not surprisingly, they are engaged in battles with several popular gun magazines, the AMA, The Journal of Trauma, the federal medical establishment, and several self-styled stopping power "experts." Quite readable, very informative, not for wimps.

## General Reloading

*Complete Guide to Handloading*, by Philip B. Sharpe. Originally published by Funk & Wagnalls.

Last updated in 1953, this massive work is dated, but contains a wealth of historical data on powder and cartridge evolution as well as the evolution of handloading. Anybody interested in the bows and whys of ammunition development will find this a treasure. Sharpe's book contains data on experiments of all sorts, many of which have a habit of turning up in contemporary magazine articles as "new" ideas and possibilities. Sharpe was a good experimenter and stands as one of the best known early experts in the field.

*Principles and Practice of Loading Ammunition*, by Earl Naramore, Small Arms Technical Publishing Company (Samworth), Georgetown, SC, 1954. 952 pp. One reprint by Stackpole Books.

This last of the Samworth books is now out of print, but hopefully someone will reprint it again. Naramore gets into the "science" of reloading, but does so in layman's terms, which makes this book very readable. His emphasis is on what happens to powder, primers, bullets, barrels and actions when guns are fired. His examination of all the forces at work and what they do is expressed in terms of how to deal with them in the reloading process. This is probably the best book when it comes to answering those "Why" and "What If" questions. Naramore and Mann were nearly the only author-experimenters who examined fired bullets,

collected in pristine condition, and observed and deduced a good bit of information therefrom. Few writers expend this kind of time and effort on their work these days.

*Handbook for Shooters and Reloaders*, by P.O. Ackley, Salt Lake City, UT, 1970, (Vol. 1), 567 pp., illus. (Vol. II), a new printing with specific new material. 495 pp., illus. \$17.95 each.

Ackley was one of the greats in the experimentation and development field of small arms and ammunition. A gunmaker and shooter who was also a good writer, Ackley put the better part of a lifetime of experience into these two books, which contain articles answering all sorts of questions regarding gun failures, pressure, headspace, wildcat cartridges, killing power, reduced loads, calculating recoil, bullet energy, loading data, etc.

*Hatcher's Notebook*, by Julian S. Hatcher, 3rd ed. 2nd printing, Stackpole Books, Harrisburg, PA 1996. 640 pp. \$29.95. Julian Hatcher can be considered one of the fathers of modern firearms writing and co-founder of the field of forensic firearms examination. Hatcher was a technical editor for the *American Rifleman* and held posts as a shooter, coach and military expert that would fill an entire page. This volume is a collection of many of his best articles on military rifles, their development, autoloading and automatic systems, recoil, headspace, triggers, barrel obstructions, military rifle strengths and weaknesses, range, velocity, recoil, etc. This is an excellent companion to the Ackley volumes.

### Special Reloading Topics

*Cast Bullets*, by E.H. Harrison, NRA Publications, Washington, DC, 1982. 144 pp. Paper covers. Out of print.

Probably one of the best books on bullet casting. It covers alloys, mould care and handling, and includes a lot of problem-solving pieces of great value when it comes to getting moulds, cast bullets and various alloys to perform the way they should. Hopefully, someone will reprint this fine volume.

*The Paper Jacket* (formerly *The Practical Paper Patched Bullet*), by Paul Matthews, Wolfe Publishing Co., Inc. Prescott, AZ, 1991. 75 pp. Paper covers. \$13.50.

If you are interested in making and shooting paper-patched bullets this is the book you need.

*Loading Cartridges for the Original 45-70 Springfield Rifle and Carbine Second Ed. Revised and Expanded*, by J.S. and Pat Wolf. Wolfs Western Traders, Sheridan, WY, 1996. 188 pp. Paper covers. \$18.95.

This book is an absolute must if you are going to load for one of these guns. Wolf researched the Frankford Arsenal's records and shot his way through several hundred pounds of lead to discover how to make these old guns shoot. The data is very likely to be valuable in working up loads for similar deep-groove rifles from the 1870-1890 era.

*The Home Guide to Cartridge Conversions*, by George C. Nonte, Jr., The Gun Room Press Highland Park, NJ, 1976. 404 pp. \$24.95.

Detailed instructions on how to make centerfire cartridges for foreign and obsolete rifles and handguns from commonly available cartridges. How to fabricate ammunition for those war souvenirs you never thought you could shoot--chamber casting, fireforming--the works. Not for beginners.

### Book Resources

Finding gun books, especially the out-of-print titles, is a difficult job and the costs are often high. There are a few approaches to finding these. The first involves time. This method takes you to used-book stores where you ask where the gun books are. After you get a dumb look in response to this question, you explain utilizing simple words and appropriate gestures to get across what you're looking for. They will direct you to the bottom of the back room where you will paw through a load of junk and occasionally find a treasure for \$1.98. The second method is to bite the bullet (a non-lead one, of course) and negotiate with the book dealers at gun shows (who know the price of everything) and pay the going rate. Now and then a bargain can be found. A third variant is the easiest way. Send your want list to Rutgers Book Center. They have about 7000 current titles and 5000 out-of-print books. They also have a publishing adjunct, The Gun Room Press, with about forty current titles.

Another source is Ray Riling Arms Books Co., which is a major source of out-of-print books in the firearms field with more than 6000 titles. They also have a publishing arm with a few titles in print at the present time.

After the quest  
for fire and  
knowledge,  
what's next?  
Truth?  
Or maybe just a  
one-hole group.

# Quest For Accuracy

By DAVE WORKMAN

**WORTHY OF A HANDSHAKE**, at the very least, is the gentleman who first discovered rifling and its effect on the downrange performance of a projectile.

Between then and now, there has been quite a bit of improvement, but one thing has remained constant. We have all been trying to achieve — what's that word? — perfection in combining quality firearms with quality, dependable ammunition in pursuit of accuracy.

After all is said and done, that's why so many people have taken to reloading their own ammunition. Thousands of rounds of rifle and pistol ammunition have gone through my presses over the course of many years, and what was I after? Same thing anyone is looking for when they start brewing their own loads: The ability to send a bullet to a specific spot on a target, whether it is paper, plastic, metal or a live game animal.

In short, I was looking for accuracy.

But just what is accuracy? Is it a little cloverleaf-shaped hole at 100 yards or farther away from the muzzle? Is it the ability to hit

an 8-inch paper plate off hand at 100 yards in order to qualify for a hunting license in some foreign land? Is it managing to empty a magazine into the center of a humanoid target rapid fire?

The discussion about accuracy can quickly deteriorate, of course, about as fast as the debate over which caliber is best for a particular hunting or shooting endeavor. The reason is that there are various definitions of accuracy; perhaps as many ways as there are people to define it.

For some people, it means being able to hit an 8-inch paper plate off hand with a rifle at 100 yards. For others, it means being able to hit the bullet hole you just put in that plate with subsequent shots.

Serious handloaders are not interested in mediocre accuracy. We're looking for the "perfect load" that works well in each of our guns, whether it is a handgun or rifle. It will probably be a different specific load for each individual firearm.

Naturally, there are other variables to consider, and nobody who has spent a lot of time around firearms and shooting benches will put up much of an argument about that. Different firearms do not perform exactly the same, even with the same measured loads. Take two rifles of the same make and model, with the same barrel length and same rifling twist, insert the same ammunition, fit them with the same scope and one may not deliver the same consistent accuracy as the other.

Or take one rifle, tune it up with a specific load so that you could virtually shoot to point of aim in your sleep, then change something and try to maintain that same pinpoint bullet placement.

Now, there are some who would simply tell you the "cure" for accuracy problems is a change of scope, or an adjustment to your scope. There is a certain truth to this, but why settle for one-inch groups when you can get "one hole" groups?

A couple of years ago, when experimenting with handloads for a deer hunt in Wyoming, I had sighted my 30-06 Marlin bolt-action rifle to shoot two inches high at 100 yards using a 165-grain Speer boattail ahead of 47.5 grains of H4895 with a CCI 200 large rifle primer in Winchester brass. With this particular load, in that rifle, I was managing groups well within minute-of-angle.

Then I got creative, and tried the same powder charge in



Quality components are essential to loading accurate ammunition. Measure your cases with a dial caliper, round up quality bullets, powder, primers and tools, and rely on your loading manual.

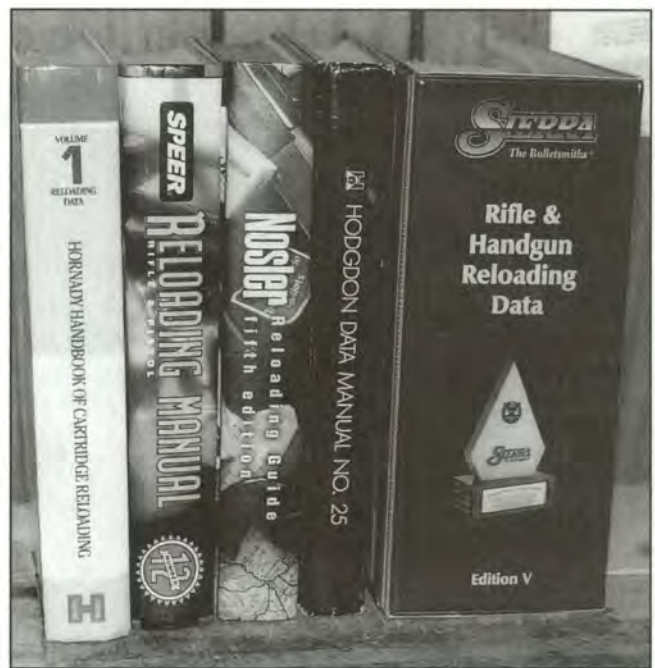

Round up good loading manuals, and get more than one. These are terrific references.

the same brass with the same primer, but using a Nosler 165-grain Ballistic Tip and guess what? I suddenly found my groups drifting consistently about two to three inches to the left, and loosening up a bit. Of course, a simple adjustment of the scope brought my groups pretty much back into line, but given the fact that the rifle in question is one of the best, the two renowned projectiles weighed the same, and the powder charge was the same, give or take a granule or two, this is proof that one cannot be guaranteed the same accuracy when one changes a critical component of the equation.

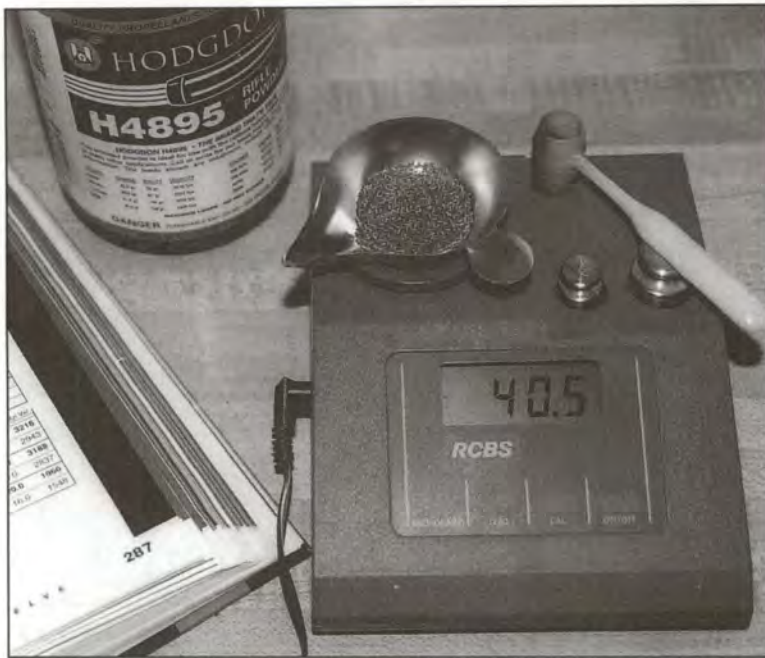

Carefully weigh your powder charges. Good electronic scales are accurate.

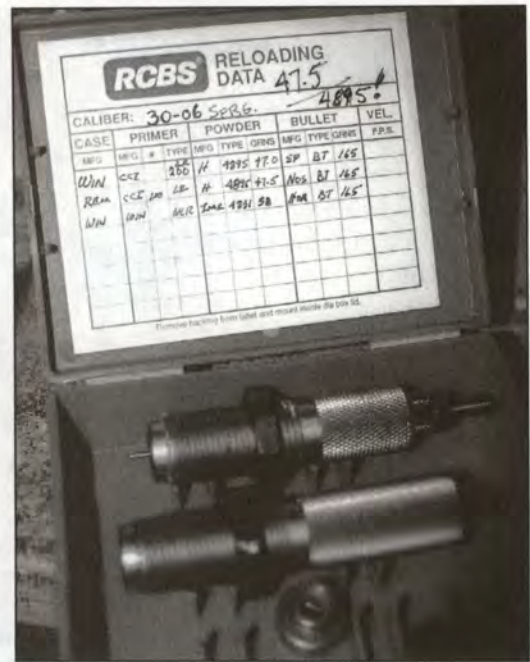

Log your favorite loads for quick reference. Author writes his down on stick-on label inside lid of his reloading die boxes.

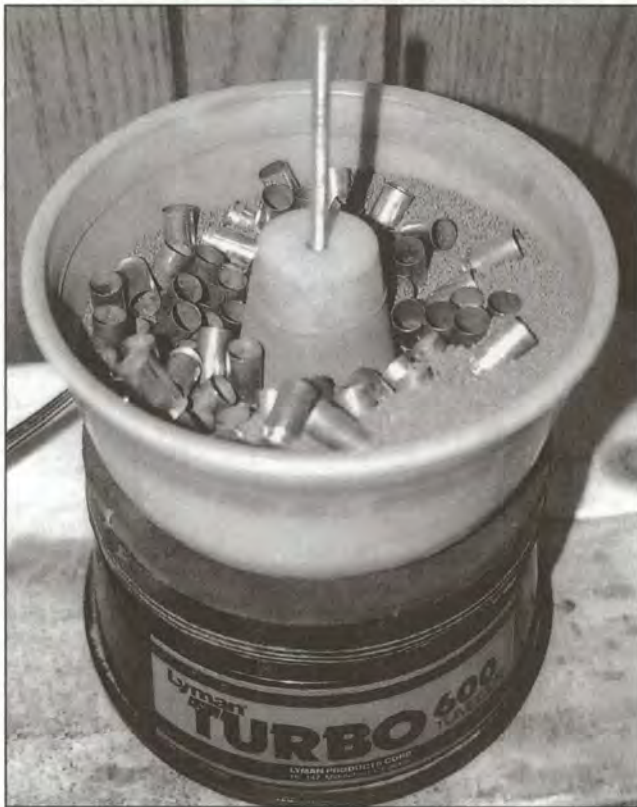

Clean brass makes for good reloads. Author tumbles his in this Lyman Turbo 600 to produce sparkling cases that are just like new.

Three-shot, 100-yard groups fired from my 257 Roberts, using 37 grains of H4895 — identified as the maximum load in both the Nosler and Hodgdon manuals — in Remington brass and the 100-grain Nosler Ballistic Tip with CCI 200

primers are typically within the 1-inch group. I get similar tight groups when I switch to Speer boattails, though the point of impact on a 100-yard target will shift. As a result, I have to adjust my scope only a click or two to bring shots right back into the little cluster of holes. Deer I've shot with this rifle fell to single well-placed bullets.

There was no "luck" involved in any of these shots — save, perhaps, the luck of actually finding a deer to shoot — because I have spent hours at the range with that rifle. I have absolute confidence that it shoots where it is aimed. I had no doubt that once the crosshairs were settled, those deer were as good as in the freezer.

Beyond the differences in firearms, external forces are always at work: wind, temperature and humidity being the chief culprits.

But there are steps that experienced handloaders will take to boost their odds of producing the most accurate loads possible for their particular firearm.

**For starters, use good components**

You're smart to spend time going through your brass, checking it for signs of stress, carefully checking it with a micrometer for length, and resizing it according to the specifications in your loading manual.

If you start with brand new, unfired brass, it is still a good idea to examine every case. One thing about using new brass that tends to become an advantage to later reloading, is that if you plan to fire these cartridges from only one firearm, they will not need to be resized too strenuously to work in the same gun again.

This is particularly true for necked cartridges, because they typically only need to be "neck sized," that is, run the case into the die just far enough to resize the neck so it is constricted for the bullet.





After the case is primed and powder added, author loads rifle cases one a time in this single-stage press.

#### *Have more than one loading manual for reference*

My reloading library includes loading manuals from Speer, Lyman, Sierra, Hornady, Nosler and Hodgdon, and I frequently surprise myself by consulting more than one, comparing data for various loads. This is not because I don't trust the loading manuals, or because I can't find a load that I like. It's more of an on-going educational process that every conscientious handloader goes through, in search of that "perfect" load.

You will find that not every manual lists the same loads with the same powders. Indeed, my Speer manual does not, for example, even list a load using H-4895 behind a 100-grain bullet for the 257 Roberts cartridge, which some old-timers insist is the finest mule deer round on the landscape. My Nosler and Hodgdon manuals both agree that a charge of 37 grains is the maximum, and Nosler's book even shows this as the "Most Accurate" load.

Now, turn to the Sierra manual, and it also has data for the Sierra 100-grain boattail, but for IMR 4895, not H-4895, and suggested loads go all the way up to 39.3 grains, to achieve 3000 fps muzzle velocity.

#### *Don't mix or substitute propellants*

Who cares what you may have read, or at least *thought* you read, in some book or magazine somewhere? Who cares what your buddy down at the gun range said he does? Mixing propellants or substituting one for another is a perilous proposition at best, and the least of your resulting problems might be faulty accuracy, or none at all.

Consider, for example, the previously mentioned H-4895 and IMR 4895. They're both rifle powders, and by name



Especially with rifle cases, it is critical to check their length before reloading, to see that they will chamber properly. Another essential process for producing accurate loads is to clean and prepare cases. If it is necessary to trim a case, the mouth should be prepared by removing any sharp edges.

they sound almost the same, but they are not the same, as Chris Hodgdon confirmed. IMR 4895 has a slightly faster burn rate than the Hodgdon powder, which has a smaller size kernel. They are not interchangeable.

Read up on the propellant you are going to use, and stick to loading data specifically for that powder, and not something that only "sounds" like your powder.

Don't mix components. Many precision shooters separate all their brass by brand name, and even finish (nickel brass as opposed to plain yellow brass). They weigh each bullet, and for good reason. If you are building match-quality loads for, say, a 165-grain bullet, it is important for consistency that your bullets all actually weigh 165 grains.

Bullet weight and style are of critical importance for precision shooting, and this is where it is important for a shooter to know the rifling twist. Longer, heavier bullets typically perform better when fired from barrels with tighter rifling twists, while shorter, lighter bullets tend to do better when fired through barrels with a slower twist.

If you find that your gun shoots good, tight groups with one type of bullet of a certain weight, don't think you can switch bullet brands or types—even if they weigh the same—and maintain that degree of accuracy. I've tried this, and it doesn't work, as my experience with the 30-06 detailed earlier attests.

Different types of bullets of the same weight will, for example, have different bearing surfaces. That's the part of the projectile that comes in contact with the rifling in the bore. Most assuredly, bullets of different weights and designs will have different bearing surfaces. This change in bearing surface can affect downrange accuracy, given that all the other components have remained the same.

Ditto your propellant. If you find a propellant charge that is consistently accurate and comfortable to shoot, don't mess with it by switching propellants and trying to duplicate your

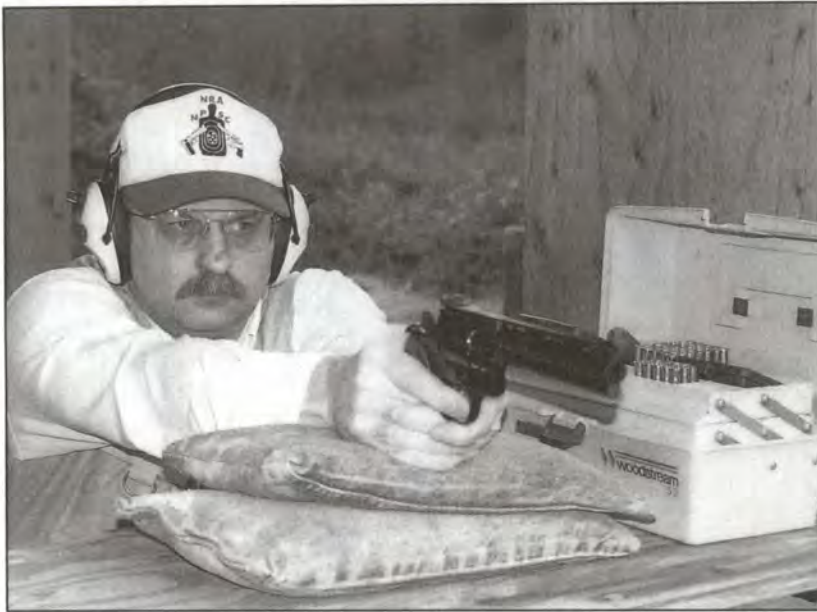

Determining how accurate your loads are requires that you test them at the range. Author spends many a daylight hour with such guns as this Colt Python to assure that his loads work as needed in the field.

Author at the bench with his 257 Roberts, topped by a Kahles variable scope. His two favorite loads both use 100-grain bullets, either Speer boattail or Nosler Ballistic Tip.



results. It would be something on the order of a miracle if that happened.

This is where the "If it ain't broke, don't fix it" principle truly applies.

On the other hand, if you work up loads that are turning in only moderate accuracy — say you're shooting two-inch groups at 100 yards and it doesn't seem to improve — then a switch in components is certainly an option to be considered.

Get a reliable scale. Today's electronic scales are the best you can buy, and they are worth the investment if you are serious about producing consistently accurate ammunition. If your scale is not accurate, you are going to be producing powder charges that are inconsistent, and that inconsistency will carry directly over to your accuracy, which will evaporate.

#### ***Pay attention to the gun***

As noted earlier, different firearms perform differently with the same ammunition. It is just possible that a change in bullet weight or design, or by adding or subtracting a

half-grain of powder, you find the results for which you have been searching.

A word of warning: Accuracy quickly falls victim to bad sights, poor optics, a poorly-fitted stock and any number of other things or a combination thereof. I had worked up a slam-bang load for my Marlin 30-06 bolt-action rifle one year, and then changed the barreled action into a more fancy stock. To my chagrin, I suddenly could not produce a group that stayed within 5 or 6 inches at 100 yards. It turned out that the floating barrel really wasn't floating at all, and part of the wood in the barrel channel was bumping up to the bottom of the barrel. I ran a dollar bill down around the barrel to discover this problem, then went to work with sandpaper wrapped around a dowel. Soon, the newly-stocked rifle was shooting nice groups again.

Crummy optics, or loose rings or mounts can send your groups into the Twilight Zone. Get a good scope for your rifle, or hunting handgun if that's what you use, and make sure it is mounted tightly.

If your accuracy suddenly takes a turn south with a batch



**What is accuracy?** Here, author shows a 25-yard target into which he fired 200-grain factory loads on a test of the ammunition's performance in his customized Auto Ordnance 45 pistol. But author has found that his groups can tighten up when he stokes magazines with handloads using 230-grain Speer TMJ bullets over a charge of HP-38.



of new handloads, it may not be the fault of the ammunition. Check the gun first to see that all is secure, and then start worrying about the loads. It is possible that your sights or scope may have been banged out of zero.

All of this takes time, of course. For some, it is an endeavor that spans years. One of my hunting partners has been loading his own cartridges for many years, and not long ago he told me that he has been keeping range journals on his experiences. He tests groups of cartridges with certain powder charges and specific projectiles, and logs the results by date. He can literally pull one of these journals and look up the data for loads he was using on a certain date and see how they shot.

This guy has already found several very good loads that work in his various rifles. But that has not stopped him from trying to improve his results. Now retired, I suppose it is his form of recreation, but I've witnessed this fellow shoot some phenomenal groups with loads he has already developed. In my opinion, he has already achieved accuracy, and while it may not be "perfect," being able to punch holes through the X-ring time after time is about as close as it gets, and hardly reason to complain.

#### **Field versus Street**

Up to now, we've been concentrating on the sporting aspects of accuracy. The debate takes on a different complexion when we begin discussing bullet placement on the street. We're not going to open a debate over the legal and social advantages of factory defensive ammunition versus a reliable cartridge one develops on his own loading press. That's a discussion best carried on in legal circles. Likewise, this is not a debate over whether one should or should not shoot.

What I'm talking about is what one might consider acceptable accuracy in a defensive situation. Over the years, I have listened to the pontifications of various "experts" on this subject. Some consider it "accurate" shooting for a shooter to be able to place all of his or her shots, under pressure, within the circumference of an 8-inch circle at 25 yards. Others might suggest that getting all of your rounds in that same size circle at a mere seven yards is "accurate" shooting if you're firing fast, and your life depends on it.

There are many definitions of "accuracy" when it involves a discussion about defensive firearms. First and foremost is the ability to hit the target.

A deputy sheriff friend of mine once enlisted my help in setting up a shooting scenario through which he planned to run all the officers in his precinct. He gave me a "sort of" idea about what he wanted to accomplish, so over lunch one afternoon, I explained to him something that he has apparently been passing on to his fellow officers ever since.

"Your exercise must stress hitting the aggressive target," I explained. "Everything else is secondary, because *a bullet that misses the target is going to hit something else.*"

This is essentially the same thing volunteer instructors stress to kids in a hunter education course about sight alignment, shot placement and checking your background, and if they don't they ought to. On the street, especially in today's litigious legal environment, accuracy and the ability to not miss is why so many serious, legally armed private citizens and police officers spend considerable amounts of time on shooting ranges.

Defensive handguns are not target pistols, though with ample practice, shooters can become remarkably proficient.



For defense and "street" applications, accuracy may be measured by how well one can place rounds on a target at 7 yards, the range of a gunfight.



And here's the result of author's rapid-fire exercise, and this would be considered accurate rapid fire shooting under a stressful situation.

I happen to own a couple of 45 ACP handguns that were essentially designed for street carry, but are stunningly accurate, especially when loaded with the ammunition I produce at my own loading bench.

Here, again, these pistols perform a bit differently because in handguns, just as with rifles, one load does not "fit" all.

Perhaps my favorite all-purpose 45 ACP round is 6.8 grains of HP-38 behind a 185-grain Nosler JHP. In three of my four 1911-type semi-autos, this round feeds reliably and is accurate enough to have served me well in the days when I competed in action pistol shoots at the local gun club, and still delivers the goods when I practice "just to keep my hand in."

And just how accurate is that load? It works well enough to allow me to roll a 12-ounce tin can around a 25-yard pistol pit, even when I'm shooting at the bottom end of a can lying on its side. It works well enough that at ten yards, I can empty a magazine into a playing card stapled to a backboard.

Just how much closer to point of aim does one need to shoot with a defensive handgun? What's typically more important in such a situation is how close one is to the target. At such distances, pinpoint accuracy is rarely an issue.

Take the Model 19 Smith & Wesson Combat Magnum with its 2 1/2-inch barrel. This revolver has adjustable sights, and they're not simply ornaments. It is a pretty accurate defensive handgun with the right loads, and I've discovered that out of my particular specimen, a 357 Magnum cartridge pushing a 125-grain Speer JHP ahead of 17.5 grains of 2400 or 19 grains of H110 really delivers the goods, with minor tinkering on the rear sight. It also does rather well with a +P 38 Special, such as the load one gets with a load of 5 grains of Winchester 231 behind a 125-grain Hornady JHP, or 10.8 grains of 2400 ignited by a CCI 550 Magnum primer, propelling a 125-grain Speer JHP. The latter load worked very well for me early in my shooting career, but it

does tend to leave a telltale residue of yellow flakes.

Such loads are listed in the various manuals, and my strong advice is to work up to them gradually, and not just in the interest of safety. Producing +P or magnum loads requires a bit of patience, considerable attention to your loading manuals and range time. Watch for signs of excessive pressure, particularly flattened primers and cases that do not readily eject from the cylinder. If such signs appear, back off your loads immediately. You'll be doing a favor to your gun, your hand, and your accuracy. It has been my experience that "hot" loads are not always reliable, and I have watched my tight groups, fired with comfortable loads, go to pot with more sizzling rounds.

The moral of this story: Greater energy does not necessarily translate to improved accuracy.

Years ago, when I first got into target shooting with a revolver, my first serious handgun was a Model 19 Smith & Wesson with a 6-inch barrel. My absolute favorite target round for this gun consists of a 158-grain semi-wadcutter lead bullet pushed by 3.5 grains of HP-38, with a CCI 500 small pistol primer. I used that revolver for hunting, and anytime I missed, it was not by much. Just because I may have sailed a bullet over the head of some cottontail a fraction of an inch does not mean the load and/or gun failed.

Which brings us around to the last, and arguably most important, part of any accuracy debate: The shooter.

Even using the finest firearm and the best ammunition, accuracy is still greatly dependent upon the man or woman behind the trigger. Precise bullet placement requires concentration, sometimes hesitation. A last second twitch on the trigger, a blink, nudge or even an irregular pulse beat can all interfere with this thing called accuracy.

Invest the time, both at the loading bench and the shooting bench, developing ammunition that consistently shoots to point of aim. Once that goal is reached, you have achieved accuracy. Then it's up to you to do your part.

Before worrying about things like standard deviation, shot-to-shot uniformity and extreme spread, it is important to remember the basic function of a chronograph is to measure velocity.

# The Chronograph

By MIKE THOMAS

**I BEGAN HANDLOADING** ammunition in 1964. My start was a modest one. Equipment consisted of an R.F. Wells "C" press, 30-06 dies and powder scale from the same company, as well their deburring tool. I used that equipment for a long time. The deburring tool, now dulled from much use, sits atop my desk as a paperweight. Oh yes, I almost forgot the Wells clear plastic powder funnel. I still use it. All sorts of reloading equipment and accessories have come and gone in forty years. Most of it has been well made, works as it should, and will last just short of forever. Some of it was of flimsy construction and actually junk when purchased. Other items were superfluous gadgets, developed to fill needs that never existed, except in the minds of strange people. However, even we strange people come to our senses on occasion.

In 1964, there actually were a few chronographs on the market. We did not hear or read much about them, however. One had to be a deep-pocketed incredible fanatic to own one, at least to this author's way of thinking at the time.

Avtron Manufacturing, Inc. began selling chronographs in the early '60s. The company marketed a transistorized model that weighed thirteen pounds, including batteries. It sold for under \$350, according to the 1965 GUN DIGEST. The same publication lists the retail price of a Mark V Weatherby rifle at \$285. There were other chronographs as well. Some were much cheaper than the Avtron, but comparatively, they were quite a bit more expensive than what is available today. They were also bulkier and more temperamental to use than what is on the current market. Most, if not all units then used expendable skyscreens that were replaced after each shot.

Why would anyone want or need such an instrument? A chronograph only measured velocity, and velocity figures were published in all of the handloading manuals. The figures had to be accurate because the people who compiled the data used chronographs, probably far more sophisticated units than an individual hobbyist could buy.

That is all very true. The published velocity with a particular load was correct. However, it was correct *only for that test rifle* or the special receiver device on which a test barrel was installed. Controlled laboratory conditions were often far different than what one might encounter on a makeshift outdoor range. The myriad variables that affect velocity become very evident.

I bought my first chronograph, an Oehler Model 12, around 1980. Seems like the cost was around \$100.00. No

longer were the expendable skyscreens necessary. The unit did not give a direct velocity readout. A knob was turned after a shot and a series of four numbers were recorded. A tarage table booklet, supplied with the chronograph, was used to convert the number series into a velocity figure. My description sounds like far more work than the process actually was. Nevertheless, the procedure was slow if many readings were taken. By this time, a number of chronographs were on the market and that situation exists today. I've used only four chronographs in the past twenty some-odd years, so there are many I have not tried. I have had good luck with units made by Custom Chronograph, Inc., P.A.C.T., Inc., and Oehler Research, Inc. The chronograph market appears to be fiercely competitive. This observation would lead one to believe that most everything out there must work well for the companies to remain in business.

This article is not intended as a roundup-type essay on contemporary chronographs. Particulars on specific units are available from many sources that include manufacturers' websites, catalogs, and firearms publications. Rather, it is intended as a basic primer for the purchase and general use of a chronograph for the serious handloader.

As with just about anything else that can be purchased in this world, some chronographs have more features than others. It is up to the individual as to how much in the way of technological attributes are necessary. It is important to remember, however, that the basic function of a chronograph is to measure velocity. We hear terms like standard deviation, shot-to-shot uniformity, and extreme spread, all by-products obtained by first measuring velocity.

Standard deviation is the way shot-to-shot uniformity is



Author's first chronograph was this Oehler Model 12 of 1980 vintage. Perhaps a little slow by contemporary standards, it was affordable and worked well.



There is certainly nothing wrong with a chronograph that has the entire unit ahead of the shooter, but utmost care is necessary to keep from destroying the instrument with an errant bullet. Chronograph pictured is a SpeedTach by Custom Chronograph Co. that the author used in the mid-'80s.



This SpeedTach was dealt a fatal blow by a cast 9mm bullet, something to consider when using an "up front"-type instrument.



Don't forget a notebook when chronographing loads! Chronograph printers are fine for their designed purpose. However, in the author's opinion, additional notes are necessary. See text.



Author chronographing 375 H&H Magnum loads using a P.A.C.T. chronograph, an excellent instrument.

measured. The smaller the deviation between shots, the more uniform a load is. Please note here I did not type the word "accurate", but rather "uniform". Extreme spread is simply the difference between the load registering the lowest velocity and the one recording the highest velocity in a string. In my case, the string normally consists of five shots, as when working up a load. A "summary" may contain average velocity, high velocity, low velocity, standard deviation, and extreme spread all nicely calculated on an electronic readout. Printers are available for many chronographs, providing a hard copy of data.

Personally, I prefer "extreme spread" to "standard deviation". I believe that standard deviation currently may be the more used and / or accepted measurement. And, while splitting hairs, it seems to me that standard deviation is the more exact of the two. When I see the words "extreme spread", however, it registers in my low-tech mind in a more meaningful way than "standard deviation" does.

Obviously, it takes a few minutes to set everything up, and get the firearm, chronograph screens, and target in proper alignment. This is extremely important and manufacturers' have suggestions as to how this is best done. Once everything is in position, however, one not only chronographs but shoots for group as well. Actually, it's a rather efficient process. I normally set the closest screen 10 feet from the gun muzzle regardless of whether I use a rifle or handgun. This distance has become an arbitrary standard. It may minimize possible muzzle blast damage to the screens compared to a closer spacing. One who shoots a great deal of lubricated cast bullets over a chronograph (as I do), soon discovers tiny bits of bullet lube on the screens. That does not seem to hurt anything and I've yet to see a need to clean them. One word of caution when setting up skyscreens. Don't armorplate them! In the past, some chronograph users tried to prevent errant bullet damage to skyscreen parts by placing a piece of steel in front of them. I don't care

to shoot close to a piece of steel that's just a few feet in front of my face with any bullet known to man. Be careful with shots; place them where they need to go. Should you hit an expendable part, it's often cheap to replace. This I know well, as I have replaced numerous shot-up parts over the years. Anyone who chronographs many rounds over a period of years will "kill" a part or two occasionally. While on the subject of killing, some chronographs have only skyscreens and/or other expendable parts in front of the firearm. With other instruments, the entire one-piece unit is starkly out there before the muzzle. This may or may not be an important consideration



From the muzzle to the chronograph's first screen should be approximately ten feet regardless of whether rifle or handgun is used. Oehler recommends three feet for chronographing shotgun loads.



Oehler Model 35P with built-in printer has seen much use over more than a decade.

before making a purchase. Shoot a one-piece between the eyes and it's more than likely dead. I've done that, too. Look at the photograph of my Custom Chronograph SpeedTach. Notice the 9mm cast bullet entrance wound. Needless to say, the projectile wreaked havoc on the chronograph's innards. I shed no tears as I had used the unit to chronograph an untold number of rounds before that carelessly placed shot. I suppose I was ready to try a different unit anyway. It is something to consider.

I experienced some shocking revelations after purchasing my first chronograph. Many other folks have had the same experiences. The velocities of assorted handloads varied considerably from those in the loading manuals. Sometimes my velocities were higher, but, more often than not, they were lower, often considerably lower. Here again, all those variables come into play. Look at the fine print in the handloading manual. Was a Remington 700 with a 20-inch barrel, just like yours, used to record the data? Or was the test gun a Model 70 Winchester with a 26-inch tube? It often makes a big difference. To further compound matters, two identical Ruger bolt-actions with barrels of the same length may yield muzzle velocities that consistently vary by more than 100 feet per second. That is a bit unusual, granted, but it happens. 'Tis far easier to use a chronograph to determine the velocity of *your* loads in *your* rifle or handgun. I choose not to clutter my mind with the variables. No amount of educated guessing can come close to what a chronograph is capable of doing.

Before chronographs were widely available, an untold number of articles and books were published that contained loading data with "estimated" velocities. Some material did not even use that word in reference to velocities. The most optimistic data ever published had to be that dealing

with wildcat cartridges. In some cases, it appeared that the developer of a wildcat would estimate velocity as closely as possible, then add several hundred feet per second. The P.O. Ackley two-volume set entitled *Handbook For Shooters And Reloaders* comes to mind. Though somewhat dated, this is an excellent reference work every serious handloader should possess. I am in no way critical of the knowledgeable and well-respected Mr. Ackley. However, numerous wildcat developers from years ago sent Ackley data on cartridges they developed for inclusion in his books. While the loads were likely safe, there are instances of rather outlandish velocity claims. I suspect these loads were not chronographed but at the time may have seemed reasonable.

Personal chronographs put an end to such unrealistic figures. We also found that some wildcat and "improved" case designs provided no velocity gain over the standard case. In their defense, however, improved shapes offered other advantages to the handloader that had nothing to do with higher velocity.

I certainly advocate the use of loading manuals. Their primary purpose is guidance in the development of safe handloads. A handloader who wants a good, safe, accurate hunting load can certainly produce just that without the use of a chronograph. By their very nature, however, many handloaders are inquisitive perfectionists and take the handloading game to lofty levels of precision. Therefore, a chronograph becomes an essential item.

I'm not a perfectionist but I am an accuracy advocate. I adhere to a policy I refer to as "practical perfection". For that reason, I usually fire five-shot groups when developing loads, as mentioned earlier. Now, 10- or 20-shot groups would certainly be more meaningful as a measurement of standard deviation. For that matter, such groups may tell us



more about the accuracy of a load. I have other things to do besides firing a few twenty-shot groups. Few of us want to turn a hobby into drudgery. It's simply not necessary.

What I mention next is solely an opinion, but I believe it to be correct and am confident that many other experienced handloaders / chronographers will share my viewpoint. The widespread use of chronographs has found some users placing far too much emphasis on the standard deviation factor and not enough on other known factors that cannot be gleaned from a chronograph. It is important to remember that low standard deviation is the result of uniform velocities. If we have uniform velocities, ammunition must be uniform. Does that tell the handloader that a state of harmony exists among the components of powder, bullet, primer, and case? Here we might step into some theoretical stuff; the answer can be both yes and no.

Examine a firearm used for load testing and chronographing. If a rifle, how's the bedding of action in the stock? What shape is the bore in? Smooth, rough? What about the firing pin? Got a weak spring, maybe, leading to faulty ignition? Is a revolver out of time? Mainspring in good shape? These are only a few of the things worth looking at.

A chronograph will not tell all. Here again, I choose to pick on the low standard deviation theorists. More than a few loads with incredibly low standard deviations shoot poorly from an accuracy standpoint. Some with questionably high standard deviations group into tiny clusters on a consistent basis. It's true that loads exhibiting low standard deviations are more likely to lead in the right direction when in search of a load that is safe, accurate, and in the desired velocity range.

Chronographing often indicates very small standard deviations with compressed powder charges. Working up and chronographing a batch of five compressed test loads with five cartridges in each group may show each group with quite low standard deviations. Maybe velocities are too low and of the five groups fired, accuracy was horrible with each. Something wrong somewhere, but the SD, ranging from 5 to 11, is great!

Another powder is used. Loads are not compressed, but the powder charge fills the case with little room to spare. No other component is changed. Twenty-five more rounds, five different charges. Accuracy is deemed mediocre with the #1 load. It gets better with the second. Loads #3 and #4 are tied as excellent. #5 is also excellent but exhibits high pressure signs, so that one's out the window. #3 and #4 are worth trying again. The SD's for all the loads were close, but considered a bit high by some, ranging from 35 to 42.

The examples are not extreme. They happen. If an SD is really wild, it is fairly safe to assume a load is highly unbalanced and will never produce decent accuracy or uniform velocity. If a load is safe, several groups have been fired that are consistently accurate, and the chronograph indicates velocity is where it should be, don't give a second thought to standard deviation figures.

How accurate are chronographs? If everything is set up

per recommendation of the manufacturer, chronographs are so accurate that we need not concern ourselves with the small possible error margin. The companies that market the instrument normally provide basic troubleshooting information with the unit. The chronographs I am familiar with have all been powered by nine-volt alkaline batteries. Some manufacturers specify a particular brand of battery. It is advisable to religiously adhere to their recommendations. These people have tested their products extensively and know what they are talking about.

Batteries last a long time. Sorry, I can't tell you how long that is; I've never kept records. I do know that I chronograph many more loads than the average user and I only replace batteries a few times a year, perhaps less than quarterly. ALWAYS keep a spare battery handy when you go to the range. I learned this lesson the hard way. Certain light conditions may draw more juice from a battery. When a battery begins to fail, the instrument may still work, but readings often become nonsensical.

Here's a tip I find useful when developing a load. Perhaps I read an article containing chronographed handloading data, some of which I might want to duplicate. Whether the author's firearm was similar to mine or not, the best published loads are sometimes a good place to start. This is especially practical if you already possess all or at least some of the recommended components. This practice may save much in the way of time, money, and wear and tear on vehicles and firearms. Additionally, some loading manuals refer in their data to specific loads that were the "most accurate tested" or perhaps mention a powder that worked particularly well in a cartridge.

Many people who use a chronograph, however, have been involved in handloading long enough to make an intelligible decision regarding component selection. While some load development is still necessary, the chance of arriving at a good load without extensive work is favorable.

Something else a chronograph will not do bears mentioning. One must keep adequate range notes. We may get the basic data on a screen, or perhaps it is printed out. I prefer to have additional information on my loads. There is little room on the printer paper to add notes, so I transfer only pertinent data to a notebook and discard the printout. I do not save targets, either. I prepare as much as possible in my notebook before a trip to the range. I record information on a particular gun, loading data, etc. Once underway at the range, I can record weather conditions, chronograph info, group size, etc. When one uses a number of different guns and loads during a two-hour chronographing session, a pile of printer paper slips may become confusing without additional notes.

I am amazed at the number of handloaders who don't own a chronograph. It is often learned, however, that they periodically accompany a friend (who happens to own a chronograph) to the range. I'm fortunate to have my own range now, but I used public ranges for years. Once they observed the equipment in place, it was a common prac-

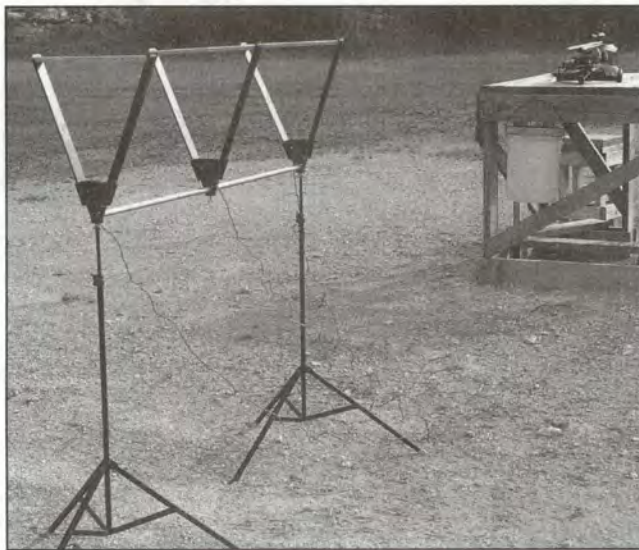

Oehler 35P completely set up, aligned with rifle and target, ready to chronograph handloads.

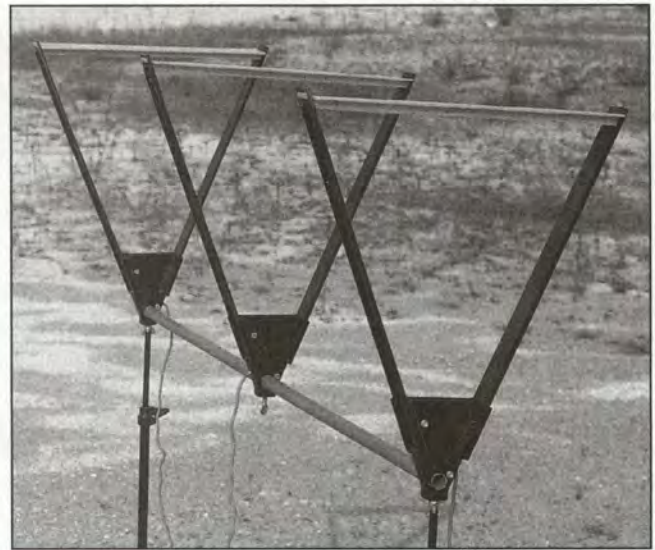

The plastic parts can be considered expendable items. They are inexpensive to replace should damage occur. Pictured are the Oehler 35P skyscreens, diffusers, rail, and rail stands.

tice for some shooters to ask if they could chronograph a load or two. I did not mind firing their rifle and load, but I never allowed a stranger to shoot over my equipment. They were always most appreciative. Perhaps some of these folks ultimately purchased a chronograph as a result of the experience.

With the technology level of today's chronographs and prices that are more reasonable than ever, virtually anyone who can afford to handload and shoot can afford a chronograph. I won't go so far as to say a handloader without one is at a great disadvantage, but the instrument is useful to the point that I would never refer to one as a gadget. It adds some fun to the game, too.

## Chronograph Manufacturers

Competition Electronics, Inc.  
3469 Precision Dr.  
Rockford, Illinois 61109  
8001-8001-8001 Fax# 815-874-8181  
[www.competitionelectronics.com](http://www.competitionelectronics.com)

P.A.C.T., Inc.  
P.O. Box 531525  
Grand Prairie, TX 75053  
214-641-0049  
[www.pact.com](http://www.pact.com)

Oehler Research, Inc.  
P.O. Box 135  
Austin, TX 78766  
512-327-6900 or 1-800-531-5125  
Fax# 512-327-6903  
[www.oehler-research.com](http://www.oehler-research.com)

Shooting Chrony, Inc.  
3269 Niagara Falls Blvd.  
N. Tonawanda, New York 14120  
6292-6292-6292  
Fax# 416-276-6295  
[www.chrony.ca](http://www.chrony.ca)



The author chronographs cast bullet loads from an FN Mauser chambered in 411 Hawk, a wildcat cartridge based on the 30-06 case.

An in-depth look  
at reasons for  
buying factory  
ammunition or  
rolling your own.

# Reloading Vs. Cheap Ammo

By CHARLES E. PETTY

**ONCE UPON A TIME** it was axiomatic that you could reload for 25-50 percent of the cost of factory ammo. That simply isn't true anymore. It all depends on what kind of ammo you want and how much of it. Before we can reach any sort of buying decision we have to first look at the market for factory ammo because it has changed dramatically. Not too long ago factory ammo was, well, factory ammo. You could make a choice based on the color of the box alone. All the biggies had comparable products but other than maybe a choice of bullet weights in some calibers we bought the same things our daddies did. Then in the 1970s Federal started their "premium" line with some ammo loaded with Sierra bullets. Things have never been the same again. That concept has expanded into all areas of the ammo business: rifle, handgun or shotgun.

The normal and inevitable progression of costs took the price of a box of ammo towards something of an



Author loading 45 Colt ammo on an RCBS Pro 2000.

investment. The manufacturers responded in two very different ways. The first thing that happened was the arrival of *generic* ammo in plain boxes. Sometimes it was exactly the same as a brand name product—but we always heard that some might be culls or rejects from more expensive brand-name loads. I never have seen proof of that and my own experience shows that generic ammo is usually a good buy.

The other change was to reduce the size of a box of higher-grade handgun ammo from 50 to 20 or 25 rounds. This was a marketing ploy that reduced the cost per box but still permitted the cost per round of ammo to increase. Human nature is such that we hardly ever bother to divide to discover the true cost. We'd just scream if a box of ammo cost \$50. You have to go some to find a 50-round box of premium handgun ammo these days. Today we can divide factory ammo into five distinct categories: premium, brand name, generic, imported and surplus. To stay within the "cheap" category we need to stick with the last three.

If we are going to make a choice between reloading and just buying the cheapest possible ammo we'll miss an opportunity because the reloader can save money at the upper end of the spectrum as well when loading premium or specialty bullets. But when we ask a reloader why he does it, the answers either deal with money or the concept that we can handload *better* ammo than the factories. Or maybe the factories don't offer what we want.

It also depends on how you define "better." For some shooters all they want is for the bullet to go faster. The sad truth is that there are very few situations where the relatively small increases (50-100 feet per second) possible with some handloads amount to a hill of beans. Very few.

Then there is an entire segment of the shooting fraternity that enjoys older guns for which factory ammo is either unavailable or prohibitively expensive. But by far the most common reason for reloading is to get lots of ammo as cheaply as possible.

One must also classify shooters by what they want to do. It seems to me that many are only interested in sheer volume of fire. Almost every time I go to the range there is someone there who will have a big stack of magazines, fill them all up, and then see how quickly they can be emptied. Those shooters are prime customers for generic or imported ammo, or candidates for high-volume reloading equipment.

Within the last 20-30 years, largely due to the efforts of Mike Dillon, high-speed or progressive loaders have become available at prices that are affordable to almost anyone who wants one. Dillon and others have advanced the technology to the point where it is possible to produce 1000 rounds or more per hour from a manually-operated loader.

But many—if not most—shooters can satisfy their needs with the simplest single-stage tool. Again, it depends on how much you want to shoot but someone who needs 100 rounds a week can easily produce that in an hour or two on a simple press.

Reloading can also be subdivided by purpose. You could almost do this on the basis of time. Benchrest shooters—you could say "accuracy nuts"—do not care one whit if it takes a lot of time to prepare a piece of brass or load a cartridge. Nor do they particularly care about the cost of



Everything is arranged for speed (RCBS Case Slick really helps on big cases even though carbide dies are used).



Closeup showing RCBS APS primer feed.

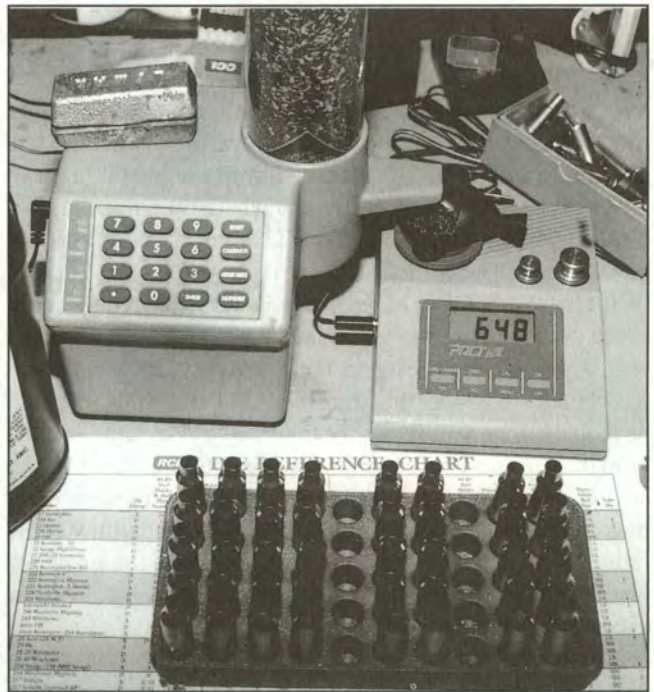

PACT digital scale and powder dispenser speeds up loading rifle ammo.

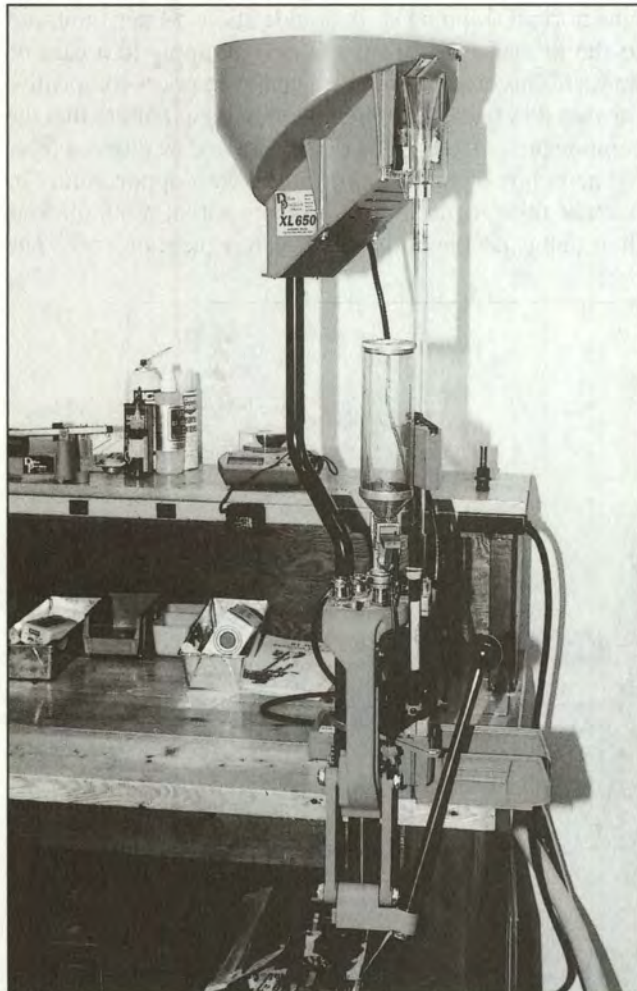

Dillon XL 650 with automatic case feeder. All you have to do is put in a bullet and pull the handle.

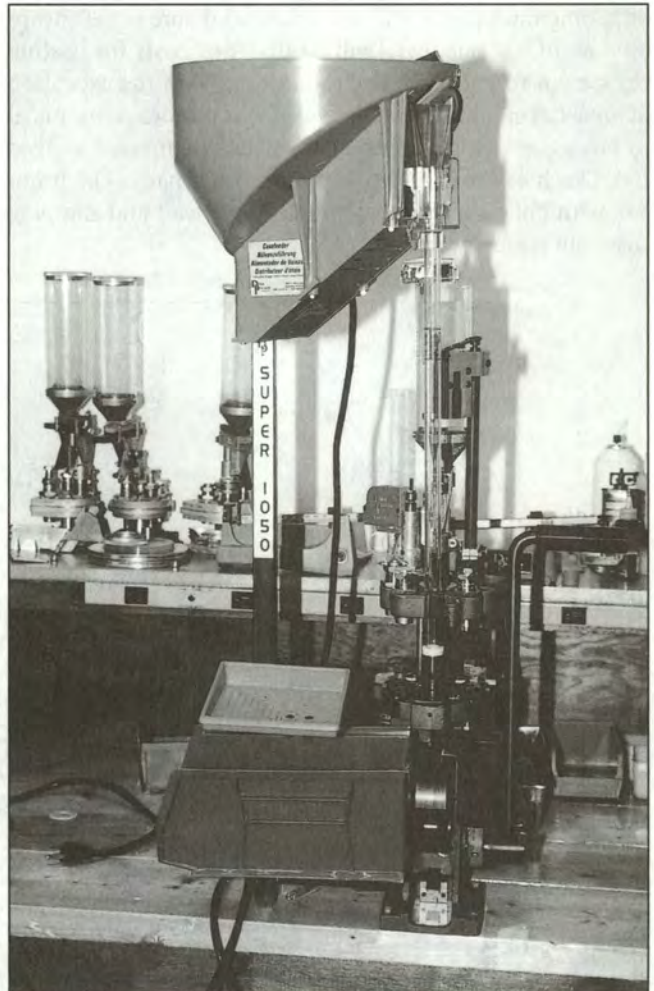

Top of the line Dillon 1050 can load around 1000 rounds per hour.

components if they do what is wanted. For some, reloading itself is the hobby. But the shooter who shoots a lot may have a different perspective and will want the lowest cost per round as long as the ammo is reliable and safe. And these are the people who need to look carefully at the time it takes to produce the ammo and determine whether or not that is a productive use. A busy, highly paid technical or professional guy might well be better off buying ammo.

But for someone with free time who doesn't need to worry about dollars per hour the picture may be different. Now the cost of components becomes the primary issue. This picture has changed considerably over the years and while inflation has touched every part of shooting, we've also witnessed the growth of a market for bulk components that can be very advantageous. When I started reloading the only way to get brass was to shoot factory ammo or scrounge mightily at the range for a piece of brass that escaped. With the relatively new availability of bulk brass the bullet has become the most expensive component.

For most of my competitive shooting career bullet casting was a significant and mandatory part of life. It wasn't too hard to find gas stations or tire stores who had scrap wheel weights and most were happy to have somebody haul them off. Sometimes that is still possible—and it sure is the cheapest way of all—but there will be up-front costs for casting equipment to consider. I've found that, with the exception of unusual calibers or weights it is often more economical to buy good quality cast bullets or the commercial swaged styles such as those sold by Speer and Hornady. The problem with bullets is that they are heavy as lead and shipping costs can erase any saving.

Within the last decade or two we've witnessed the growth of commercial casting businesses on a regional level. To be sure there are those with national distribution such as Oregon Trail or National Bullet Co. but freight costs are a factor and the regional shops can be highly competitive. Where I live there are gun shows about every quarter and there's a guy there with a trailer full of bullets. Then all I've got to do is haul them home. To me that is the most economical approach and I try to plan ahead to buy large enough quantities to last awhile and also get a bit of a quantity discount.

When I was doing all my high-volume shooting, powder and primers were a very small cost factor. You can load a whole bunch of 38 or 45 target loads from a 3 lb. can of Bullseye, and buying primers in case (5000) quantities got a break, too. I figured that it cost no more than two cents for a 45 ACP target load and even less for a 38 Special when I cast the bullets from free wheel weights and bought only powder and primers. Those days are long gone and powder that used to cost \$1/lb is 10-20 times more. Primers today cost more than the whole shebang did back then. Today when you set out to buy powder and primers hazmat shipping charges can wipe out most savings on mail orders. For example a case of 5000 primers earns \$15-20 in extra fees, plus normal shipping so that adds about \$4 per thousand to the primer cost. The same charges apply to a case of powder. This often makes local gun shop prices competitive because they usually buy in large enough quantities that the components can be shipped by freight and avoid extra fees.

The hobby of handloading is rife with opportunities to practice false economy and nowhere is that more obvious than things people do to save a penny piece of brass. The

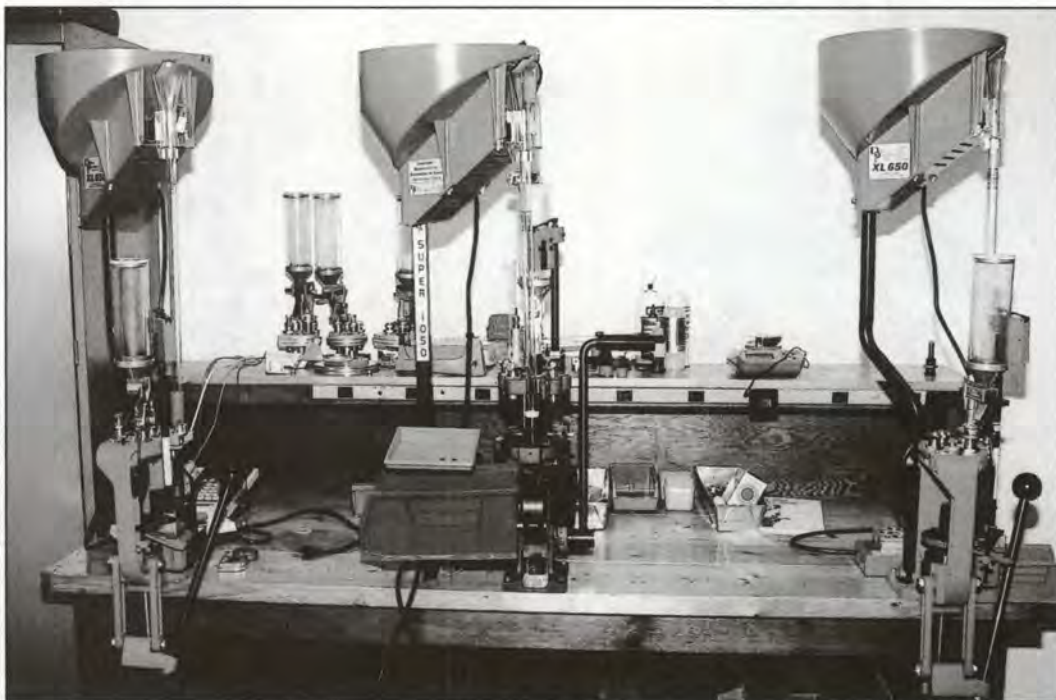

If you really need a lot of ammo, set up a bunch of Dillons. This is not a commercial setup, just a guy who shoots a lot.



Bulk-packed cast bullets are often the most economical.



Lots of powder choices.



Bullets of every shape and size.

questions usually go like, "I 'found' some brass at the range. It's black. What can I do to shine it up?" Or maybe it is military brass with a heavily crimped primer. Unless you intend to use lots of it and are willing to invest in the necessary tooling (or pay for the cleanup), GI brass is rarely a bargain. And while I am well aware of the mouths of gift horses there are times when it is wise to look real close. Brass that is found at the range may have been left there for good reason. "Converting" one cartridge case to another is also a favorite. For example, someone has some 30-06 brass but wants 308. Yes... absolutely... you could do that but you'd need a form die, a trim die and probably an inside neck reamer to do it. I wonder how much shiny new 308 brass you would have to buy to equal the cost of those tools; not to mention the hours of work it would take to turn that silk purse into a sow's ear.

## How to Shop

When we think about the costs of shooting, *how* we buy the stuff can be a big factor. As with almost any commodity purchase there are economies of scale and generally the more you buy the lower the cost per unit will be. So it always pays to buy 1000 primers instead of 100 or a bulk package of bullets instead of a box of 50 or 100. Still, we have to consider the rate at which we use any item. None of the components we need, or the ammo, will go bad in our lifetime if we take reasonable care of it. Ammo and components have a nearly indefinite shelf life with proper cool, dry storage so if a bargain presents itself and is something we use regularly then it might be good to purchase as an investment. It is probably safe to say that prices for this stuff are not going to go down.

The Internet is a powerful tool and with it we can study catalogs and compare prices from any number of sites. Entering "handloading supplies" into the Google search engine produced over 40 pages of hits and included most of the major suppliers of mail-order components and shooting supplies. It seems as if every print ad we see also has a web address where we can find more information. Many companies, such as Midway USA, will put you on an e-mail list that, in addition to regular catalog items, will feature specials and closeouts. You can point and click a bit and the big brown truck rolls up to your door. It's really pretty cool.

Occasionally closeouts present opportunities but savings can also disappear when freight and hazmat fees are added. Very often the best buys can be found close to home if you establish a rapport with local



This is about as surplus as ammo gets; be sure to find out if it is corrosive or not.

dealers. Years ago a group of us would pool our orders to get the best quantity pricing and that is no less viable today with buddies or fellow gun club members.

But the bottom line answer to the question of whether one should reload or buy ammo boils down to the cost of your time. Some folks—like me—view reloading as a nearly separate hobby and enjoy the process, but if your goal is simply to shoot a standard handgun cartridge as cheaply as possible, it's pretty hard to beat \$5-6 a box for 9mm ammo. If you're blasting something like 223 or 7.62x39 there is virtually no way to beat the cost of imported or surplus ammo.

But there's one more thing in favor of reloading. If our requirements are slightly stricter in the accuracy department, handloading may turn the tables. It is generally possible to handload ammo that will be equal to, or better than, stuff we buy based on price alone. The problem here is how we define accuracy. If your target is a soda can at 5-10 yards, it would take some real effort to make ammo that bad but handloading can also duplicate the best match ammo at a fraction of the cost. Once more, it really just depends on what you want to accomplish.

The final point to ponder is the investment in the loading equipment itself. It isn't hard to tie up a thousand dollars in a first-class loading setup, but you can do pretty well for half of that. There are lots of choices to make when buying equipment and this is one of those areas where you almost always get what you pay for. Trying to buy loading gear based on price alone often ends up costing us more money when bad choices have to be replaced. If we took Accounting 101 we know that the cost must be amortized over time and depreciated over the expected life of the item. That's well and good but then we must also calculate how long it will take for the equipment to pay for itself. And, of course, that is completely determined by how much you shoot. If you do as I do and try to shoot at least once a week, then payback can take less than a year. On the other hand if you only shoot a few times a year it could take forever.

Many things we do have unintended consequences and it seems as if they are often unhappy. That is not at all true with the decision to start reloading. Almost everyone says that they do it to save money but what frequently happens is that you can afford to shoot two—or maybe even three—times more for the same out-of-pocket cost.

More shooting is never a bad thing.

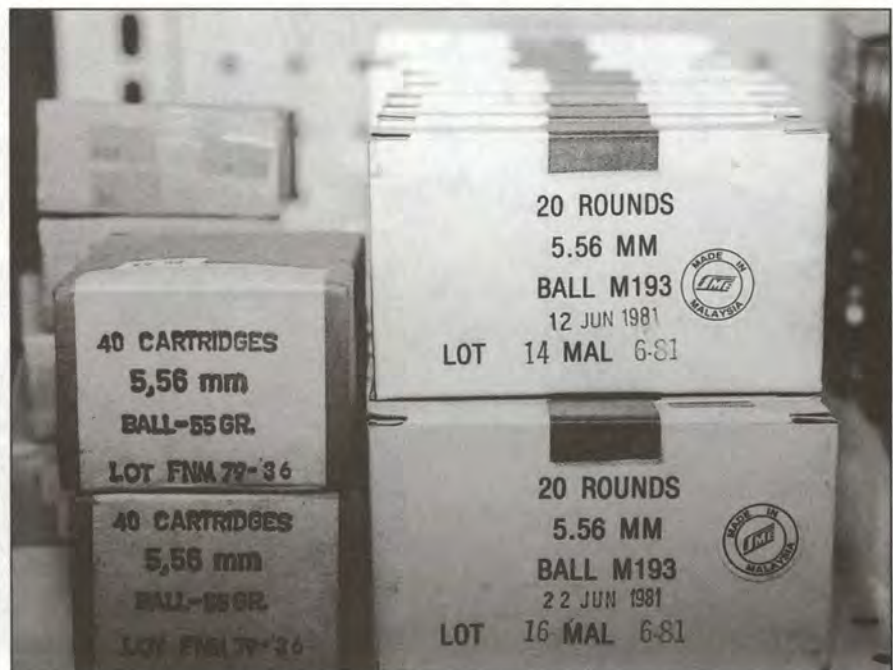

Surplus 5.56 next to packaged ammo trying to look like GI.



There is no such thing as a magic bullet for all game and all situations.

## Big Game Bullets

By CHUB EASTMAN

**AS A TEENAGER** in the late 1950s, I didn't give much thought to bullets and ballistics when hunting season rolled around. You *knew* what worked in your rifle and didn't see any reason to change. A trip to the local hardware store for a box of Winchester 30-40 Krag loaded with 220-grain Silvertips was just part of the process before the season started.

The well-worn lever-action Winchester Model 95 that Dad won in a poker game was my first big-game rifle. Included with the rifle were two boxes of Winchester ammo that had the picture of a grizzly on the front. Equipped with a Lyman peep sight attached to the side of the receiver, it shot very well and accounted for numerous western Montana whitetail, black bear, grouse and an occasional ground squirrel and coyote.

The old 30-40, with its heavy, high sectional density bullet launched at a moderate velocity, seemed to plow an adequate wound channel—with complete penetration in most cases. This was the time before hyper-velocity magnums and actual bullet failure

was rarely observed. It should also be noted that because of terrain and cover, most all critters were within 150 yards, with the majority well within 75 yards. Most observed problems were attributed to poor bullet placement rather than bullet failure.

Reloading in those days was not very sophisticated when you compare what we have today. A Lyman tong tool and a powder dipper were popular. The more advanced han-



Nice bull elk that fell to the author's 338-06 using the 210-grain Nosler Partition.



Mature bull moose in British Columbia are much bigger than the horse you are riding. Impervious to shock, it takes bullets with a high sectional density to penetrate properly.

dloaders used the newer Herter's or Hollywood presses, brand names long since forgotten. Powder measurers and scales were also quite an advancement.

Independent bullet manufacturers as we know them today were just getting started. Most bullets on the dealer shelves were from the ammunition manufacturers and the selection was limited to what bullets were used in the factory-loaded ammunition. Names like Speer, Hornady, Sierra and Nosler were brands just being recognized as an alternative to Remington and Winchester.

Being young and naïve, all the advertisements were digested as gospel and there was no such thing as bullet failure. However, things change as one gets older and a little more knowledgeable. Curiosity and experience are a wonderful combination that goes well with a focused and dedicated interest.

Over the years things have changed a lot. Bullet failure is a real possibility and is recognized more readily now than in the past. The demand for better bullet design was created when the hyper-velocity magnums became popular. Very few bullets could withstand the velocity and still maintain accuracy and terminal performance. When muzzle velocity is kept under 2,600 – 2,700 fps most any bullet designed for hunting will work, but when the 3,000 fps-plus barrier is crossed there is definite potential for bullet failure.

Hunters and shooters are sophisticated enough today that demand for performance products has kept bullet and ammunition manufacturers busy developing new offerings. What we have today that we didn't have in the late 1950s are bullets designed for specific applications. There is no such thing as the magic bullet that will perform under any conditions. Some come close... but the ultimate has yet to be developed.

Now there are bullets for the reloader and loaded ammunition for the non-reloader designed specifically for the different types of big game pursued.

Medium-size big game such as antelope, deer, caribou—and in most cases black bear—vary in “on the hoof” weight from 150-300 lbs. Granted, there are some Saskatchewan whitetails and an occasional black bear that will exceed 300 lbs. but the basic skeletal structure and thickness of hide is still the same. When measured through the chest most medium-size big game will be from 12 – 14 inches. Small and somewhat fragile bone structure is also found in the medium size big-game animals.

Granted, there is no such thing as being over-gunned but you do not need a cannon to put one of these critters on the ground. Most any modern cartridge that is



The 270 WSM with 130-grain Ballistic Silver Tip was the correct combination for this fine Texas 12-pointer.



Kahles' Karen Lutto with her trophy antelope downed with the new 243 WSSM and 100-grain PowerPoint. One shot at 225 yards is all that was needed to drop it in its tracks

6mm or larger is adequate to get the job done. One rule that should be considered: the smaller the bore size, the more sectional density of the bullet becomes important.

Example: If a 243 Winchester is used on whitetail, the bullet in available factory-loaded ammunition varies from 55 to 105 grains. The use of bullets in the 90 to 100 grain category have a much higher sectional density than the lighter offerings and sectional density is what gives you the penetration needed.

Bullet construction also plays a vital part in reliable performance; especially in the smaller bore sizes. Well-constructed controlled-expansion bullets designed for hunting are needed to get the job done properly. Lightweight bullets in a given caliber are mainly designed as varmint bullets. They will have thin jackets that are meant to disintegrate, or expand violently on impact. The heavier bullets of the same caliber are usually designed to penetrate, using a jacket heavy enough to control the expansion process after impact, and have enough retained weight to ensure the vitals are reached.

Here is a chart to give you an idea of **minimum** bullet weights by caliber for medium big game:

6 mm – 90 grains
25 Cal. – 100 grains
6.5 mm – 120 grains
270 – 130 grains
30 Cal. – 150 grains

To better explain the importance of sectional density, the ping-pong theory makes it easy to understand. What will hurt the most and cause the most damage, a ping-pong ball at 100 mph or a rock of the same size at 75 mph?

Remember, you are not going to get the perfect broadside shot each time. You need a bullet-cartridge combination that will penetrate to the vitals no matter what shot angle is presented.

What bullet works best for medium-size big game? That depends a lot on which bullet is the most accurate in your rifle, as most well-constructed hunting bullets will get the job done. Bullets like Hornady's InterLock and SST, Nosler's Ballistic Tip, Speer's Grand Slam, Remington's Core-Lokt, Winchester's Power Point, Sierra's Game King, or Swift's Sirocco will all help you put meat in the freezer.

If you are a handloader, the selection of available bullets is almost endless. You also have the advantage of brewing up a load for your rifle that gives both accuracy and performance.

The non-handloader is not at a disadvantage with today's selection of ammunition. A few years back Federal developed their "Premium" line of ammunition. They broke from tradition and used bullets from other manufacturers than themselves. They tightened up their quality control and used bullets from Sierra and Nosler to develop ammunition that was near match-grade, but designed for hunting.

Since that introduction by Federal, both Remington and Winchester have followed suit with their "Premier" and "Supreme" lines. Just recently Black Hills introduced their new "Match Grade Gold" ammunition that is loaded exclusively with Nosler Ballistic Tip and Barnes X-bullets. A handloader would be hard-pressed to duplicate the accuracy and bullet performance of loaded ammunition available today.

The second category of big game is the larger critters such as elk, moose, bison and big bad bears.

This is a different ballgame altogether. These animals



Nice four-point Wyoming mule deer killed with the author's 6.5 wildcat using the well-constructed 120-grain Nosler Ballistic Tip. Penetration at 175 yards was completely through the heart/lung area.

are two to four times the size and body weight of medium-size big game. Some can go well over 1200 lbs. on the hoof. Their skeletal structure and bone density are far greater than the deer or antelope you have been hunting. Hide and muscle are also twice as thick and much denser on the larger animals. A rib on a moose can be larger and tougher than the hollow leg bone of an antelope.

What is needed for the big critters are big tough bullets with enough horsepower behind them to penetrate a lot of hide, muscle, and bone. A raking shot on a moose quartering away from you will require a bullet strong enough, and with enough power, to penetrate nearly three feet of animal. The old saying, "use enough gun" definitely applies to the larger big-game species. What should be added to this old saying is "...with a proper bullet".

Most experienced responsible hunters and outfitters will tell you a 270 Winchester is the minimum cartridge for the larger species of big game and then only with heavy premium-type bullets. I know this will raise questions as a lot of moose have hit the ground in Scandinavia because of the old reliable 6.5x55mm Swedish Mauser, and unaccountable number of elk have bit the dust because of a well-placed shot from a 30-30. However, most of these instances can be attributed to a well-placed shot at fairly close range. Most hunters who use cartridges in this category know the limitations and are very particular about shot placement and range.

Here is another chart of **minimum** bullet weights recommended for big critters:

270 – 150 grains
7mm – 150 grains
30 Cal. – 180 grains
338 – 200 grains
9.3mm – 250 grains



Hunting partner Randy Havel and his 280 Remington did a fine job collecting this fine deer-sized impala ram.



NRA's Brian Sheetz used the new 243 WSSM and 100-grain PowerPoint to kill this trophy Wyoming pronghorn.

Back in 1949 John Nosler had a hard time with his 300 H&H when he tried to kill a bull moose in British Columbia. The 180-grain bullet he was using would not penetrate the mud-caked hide of the moose. On the way home to Oregon, he decided he could make a bullet that would work. Having an innovative mind and a full machine shop to service his trucking business, John dreamed up and made the first Partition bullet.



Jan-Olof Swanteson from Sweden used a 9.3x64 Brenneke to put this great British Columbia bull elk on his wall. One shot with using the 286-grain Brenneke bullet at 200 yards was all that was needed.



Using the proper rifle, cartridge, and bullet combination—along with good marksmanship—and this could be your pack train.



Any of these rifles will do a reliable job on big game as long as the bullet selection matches the game. (L/R) Browning A-Bolt 270 Win., custom Mauser 6.5x55, Ultra-Light Arms 284 Win., Remington Mod. 700 in 308 Win., Remington Mod. 7 AWR in 300 SUM, and the Empire Rifle in 30-06.



The old Winchester Mod. 95, 30-40 Krag was the author's first big-game rifle. Won in a poker game by his father in the mid-1950s, it doesn't take a back seat to any rifle inside 150 yards.

The next fall he and hunting partner Clarence Perdy made the trek back to British Columbia to see if that bull moose was still around. He was, and both John and Clarence came home with a set of trophy antlers and winter meat.

The Nosler Partition was the first premium bullet to hit the market. A small advertisement in the *American Rifleman* created such demand that John had to make the decision to make bullets or stick with his trucking business. The rest is history.

Since that time numerous bullet makers have come up with different variations of the Partition, or gone in a different

direction such as bonding the jacket and core together or used different variations in the metallurgy of the copper and lead.

All were trying to accomplish the same thing. Develop a bullet that would mushroom reliably, leave a large deep wound channel, and retain as much weight as possible to ensure deep penetration. Most have been successful, giving hunters the great selection of premium bullets available today.

Bullets that fit these criteria are the tried and true Nosler Partition, Barnes -X, Winchester FailSafe, Trophy Bonded, Swift A-Frame, Woodleigh Weldcore, and the newer Remington Core-Lokt Ultra, Nosler AccuBond and Hornady's InterBond.

If you are a handloader, the choices are many. It's just a matter of where your loyalty lies and what you have confidence in. For the non-reloader you don't have to take a backseat. All of the above-mentioned bullets are available in loaded ammunition of one major brand or another. In most cases, big critters take a lot of horsepower to get them on the ground.

A trip last fall to visit a couple of friends in northern British Columbia gave me the opportunity to conduct a small unofficial survey of what rifles, calibers and types of ammunition the hunters who visited the camps used. Keep in mind both outfitters' areas are trophy elk, moose and sheep only. The hunters pay a lot of money for their hunts and generally use the best equipment and products available to ensure their success.



One of the author's hunting partners and writer Steve Timm hard at work brewing up the perfect big-game load for his favored 280 Ackley.

When all the information was gathered, there weren't any surprises. By far the two most popular cartridges were the 7mm Remington Mag. and 300 Winchester Mag. Chamberings ranged from 270 Winchester to 375 H&H, –and everything in-between made a showing; especially the old 30-06, 338 Win. Mag. and Weatherby magnums.

The majority of ammunition used was factory top of the line such as Federal Premium, Remington Premier or Winchester Supreme. Quite a few handloaders but all had one thing in common. Over 90 percent of the hunters were using premium bullets of one brand or the other and most all were using the heavier offering of each brand. In 7mm the majority were using 160 or 175 grains; in 30-caliber 180 to 200 grains were popular; in 270, 150 to 160 grains, and in 338, 200 to 250 grains headed the list.

When visiting the local gun shops or hardware store and listening to hunters expound on their interest and adventures there have been two subjects of discussion that are worth a comment. The cost of bullets and ammunition usually ends up in the conversation if it goes on long enough.

When you add the cost of motels, food, fuel, repairs on equipment and licenses the little extra you pay for premium bullets or top-of-the-line loaded ammunition amounts to a very small percentage. Besides, it gives you confidence in knowing you have the best and the chance of bullet failure is greatly reduced or eliminated. Something to think about the next time you start filling out your list for hunting camp.

The next comment that usually comes up especially when bullet performance is discussed is, "Damn, I blood-shot the whole front quarter and half the backstrap". There are three things that cause this perceived problem. The first you have very little control over. Was the animal relaxed and casually munching the meadow grass or was he in a state of high alert with muscles tensed? Flex your bicep as if you were lifting 100 lbs. of dead weight with one arm then have a buddy give you a stout love tap in the middle of your



A group of 30-caliber 180-grain bullets recovered from big game. With each bullet, major bones were hit and adequate penetration realized at ranges from 75 – 250 yards. These are what well-constructed bullets should look like.

upper arm. Now relax and let your arm hang loose and have the same friend give you an equal tap in the same place. The second time you will probably feel it clear down to your elbow. (I got this information from a book written over 80 years ago by an Army colonel giving the results of small arms ammunition testing on live animals. Needless to say, they can't do that anymore.)

The next two causes of blood-shot meat you do have control over. Bullet placement and impact velocity go hand in hand to determine how much meat hits the fry pan. If major bone is hit, the wound channel is much larger and you will have a large amount of secondary projectiles (bone fragments) flying all around creating even more damage than the bullet. If you have ever center-punched a shoulder joint on an elk you know what a mess it is. You can find bone chips clear up behind the ear and halfway down the back strap.

What causes this extensive tissue damage is impact velocity of the bullet, and that's called hydrostatic shock. The harder and faster you hit the critter the more tissue damage you do, especially if bone is hit in the process.

If you are concerned with blood-shot meat, use a bigger and slower bullet. Ask most any hunter who has regressed from modern magnums and used a 45-70. His comment is usually "Eat right up to the hole". Never forget the *first* responsibility of a hunter is to dispatch the animal as quickly and humanely as possible, not how much meat is lost.

The hunter today has a large selection of bullets and loaded ammunition available for any type of big game he chooses to pursue, almost too much to choose from. Just match the ammunition that shoots best in your rifle to the game you are after.

I still have the old Model 95, 30-40 Krag. It is nestled in the far end of my gun rack, along with a few other treasured lever guns. It still shoots better than I can with peep sights.

Every now and then the urge to put on the cowboy hat and head for old deer haunts takes over and the '95 gets a chance to see daylight again. Only difference now is the magic loads worked up using newly designed bullets that shoot flatter, faster and have more *whoop-de-do* when they arrive. The only problem is I might not be able to "Eat right up to the hole" like I used to.

Something to think about.

Handloading for varmint shooting presents a challenge unique to the sport. The requirement for accuracy is a stringent one.

## Loading for Varmint Fun

By MIKE THOMAS

**ONE DOES NOT HAVE** to use a varmint cartridge for varmint shooting. Whatever firearm happens to be handy is the one that gets used. Cartridge chambering is of secondary importance. Varmint hunting, on the other hand, is a bit different. More likely than not, a true varmint cartridge is used for this sort of pest elimination.

The rancher that occasionally shoots a coyote with his 30-06 rifle probably uses the same load that is used for harvesting deer. Familiarity with the rifle, load, and point of impact at all sane ranges helps to ensure chances of hits. Furthermore, the 150- or 180-grain projectile leaves nothing to be desired in the way of bullet performance.

It is true that one can purchase or develop pure varmint loads for a favorite deer rifle. This used to be a hot topic in various firearm publications. Gunwriters liked to write about the subject and readers apparently like to read about such things, but not all that many actually went to the trouble of developing a varmint load for a 270 Winchester or 30-06, then re-zeroed a scope sight to compensate for a vastly different trajectory.

Downplayed—or not even mentioned in the old articles—were several important points. Noise level of the full-house varmint loads was at least as loud as standard loads. Felt recoil was reduced only slightly, if at all. Accuracy may have been acceptable, and at times even excellent with the light bullets, but not necessarily so in comparison with heavier bullets that were designed for the barrel's rifling twist rate. Considering the time, trouble, and expense involved, buying a varmint rifle would seem to be a more practical solution. Of course, years ago, the selection of factory varmint rifles and accompanying cartridges was not what it is today. This lack of availability likely spurred interest in the pursuit.

I've been handloading for forty years and have engaged in a number of projects of questionable merit. However, I never tried to transform a 270 Winchester rifle into a varmint gun through creative handloading. If friends who handload have given a whirl to the practice, they have yet to bring it up in conversation. As the purpose of this article, emphasis is on pure varmint cartridges, the 22-caliber centerfires. With few exceptions, anything larger is simply a hybrid, dual-purpose cartridge. That's not to say the 243 Winchester is a dud as a varmint round. Nor is criticism levied at the 17 Remington, a development seldom recognized as a general-purpose varmint cartridge. Its following is small compared to the 22s, but I assume the 17 fills a niche. Ask any 17 Remington enthusiast.

All is not lost, however. The loading tips contained herein can be successfully applied to just about any facet of the handloading game, so I make no apologies for trying to contain this manuscript within reasonable parameters.

To simplify matters despite obvious differences, let us put varmint hunting and varmint shooting on equal planes from here on out. Handloading for varmint shooting presents a challenge unique to the sport. The requirement for accuracy is a stringent one. A big game rifle capable of 2 1/2-inch groups at 100 yards is not exactly a target gun, but is perfectly adequate for the intended use at most reasonable ranges. Ideally, a varmint gun should do at least that well at 200 yards. The kill zone of a coyote is not a huge one until it is compared with that of a gopher. A woodchuck is bigger, of course, but still not a large target. I'll qualify my impeccable credibility by stating that I have never shot gophers and I have never seen a woodchuck in the real.

However, in addition to coyotes being abundant in my part of the world, we also have a healthy fox and bob-



**Cutaway neck and throat section of a bull barrel chambered for a 22-caliber centerfire varmint cartridge. For safety's sake, the case neck must have at least minimal clearance when chambered.**

cat population. Stripped of hide and hair, many gray foxes appear to be not much larger than well-fed roadrunners.

Far too many shooters capable of decent 100-yard shooting use rifles with 200-yard capabilities to attempt 300-yard shots. This happens to be the ideal formula for misses and wounded animals that suffer and/or die slow, inhumane deaths.



**The micrometer is indispensable for the serious handloader, here measuring case neck thickness.**

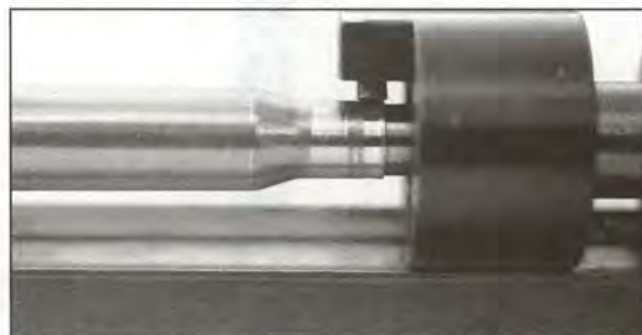

**Functioning as a miniature lathe, the Forster tool can be adjusted to remove a minute amount of brass from a case neck. The cutter, that small cylindrical piece that bears against the case neck, is raised or lowered by means of Allen screws and subsequently locked in place.**



**A case trimmer, such as this RCBS model, should be in the equipment inventory of every handloader, particularly those who load high-intensity cartridges like many of the 22 centerfires used for varmint work.**



One must be honest regarding shortcomings as well as overall shooting skills. I've found that with a decent rest, an accurate rifle, and my best loads, 300 yards (maybe a hair farther) is my maximum range on a calm day. Yes, I am aware that some shoot prairie dogs at three times that distance in 40-mile-per-hour winds, but this author is not one of them. I lack the skill and equipment for such feats. Besides, I suspect some of those folks just shoot *at* prairie dogs.

Most varmint cartridge-chambered rifles and handguns



Author bench testing a Krag-acted 219 Zipper. For those unfamiliar with the cartridge, it performs on a par with the 223 Remington but operates at lower chamber pressure due to the larger case size. Scope is a Lyman 6x silhouette model.

are capable of reasonably good accuracy straight out of the box. It is not at all uncommon these days to fire sub-one inch groups with minimal load development, but why stop there? Regarding components, we probably have too many. I am not sure if I intend that remark as witty or as practical, but look at what's available. Choices are indeed staggering. The selection of 22-caliber bullets range from a low of 33 grains to high of 80 grains. Naturally, those on either end of the spectrum are for somewhat specialized uses and not for the run-of-the-mill bolt-action rifle in 223 Remington chambering. That still leaves a very large selection in the common 40- to 60-grain range.

Current handloading manuals are the best place to begin. Compare data and don't be afraid to take notes. Select a bullet weight compatible with the cartridge. The benchrest or match hollowpoint bullets of 52 and 53 grains should not be overlooked. Some of these are of flat-base design, others are worth trying in anything from the 222 up. If there's a choice between flat base and boattail, I always try the flat base first. In my experience, they normally provide better accuracy with less load development.

Sure, one can load a 55-grain bullet in the 22 Hornet or a 40-grain slug in the 220 Swift. I'm not sure why anyone would want to bother, however. Accuracy would probably be better in either situation if a more suitable bullet were employed.

There are all sorts of Blitzes, XLCs, V-MAXs, TNTs, etc. that can be had. All are purported to serve a purpose. Some have a molybdenum disulfide "moly" coating that reduces friction and may have other more mystical attributes as well. I would recommend trying four different plain, uncoated, flat-base, spitzer bullets in two weights in the proper weight

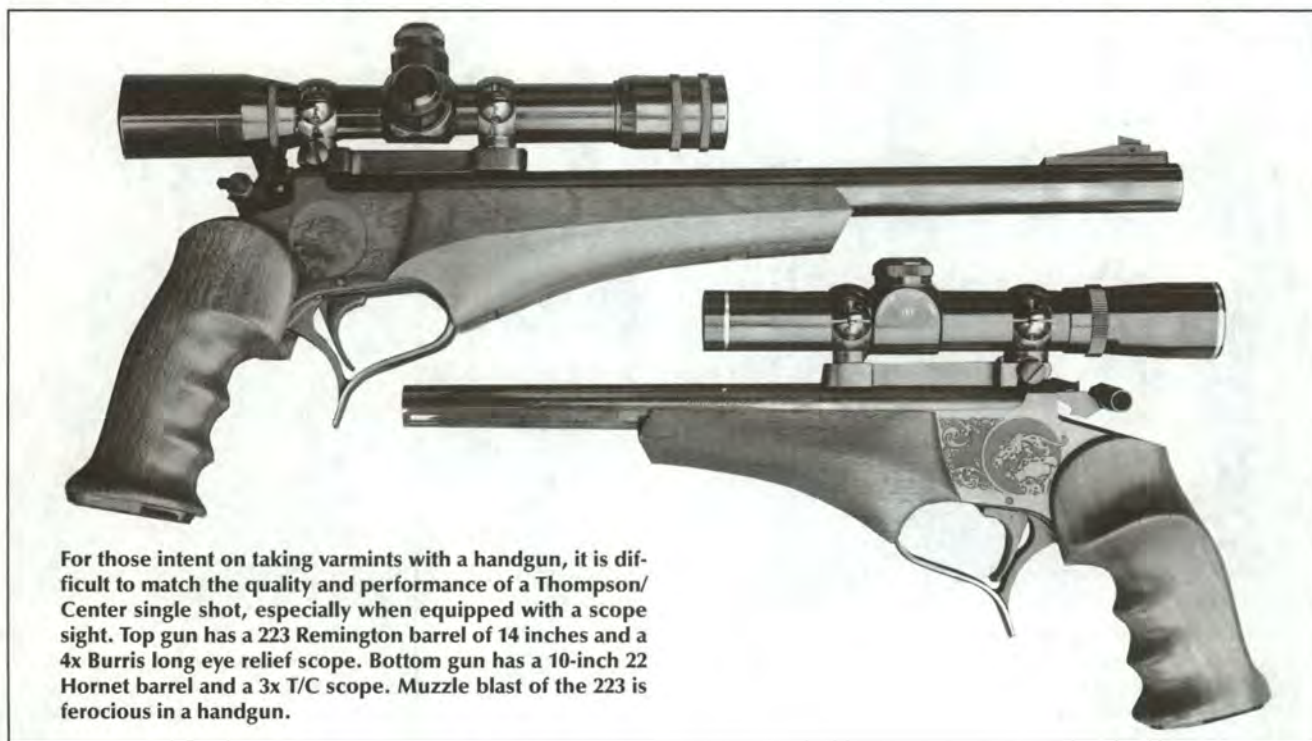

For those intent on taking varmints with a handgun, it is difficult to match the quality and performance of a Thompson/Center single shot, especially when equipped with a scope sight. Top gun has a 223 Remington barrel of 14 inches and a 4x Burris long eye relief scope. Bottom gun has a 10-inch 22 Hornet barrel and a 3x T/C scope. Muzzle blast of the 223 is ferocious in a handgun.

range to begin. One or more of these might be of the hollowpoint persuasion while others should be of soft-nose design. If finances are not an issue, select a total of six different bullets for the trial run. For varmint shooting, the full metal jacket spitzers offer no advantage whatsoever and they are far more prone to ricochet, something certainly worth consideration. I cannot perceive a practical need for such a bullet in varminting.

I recall reading material by Bob Hagel, noted gunwriter of years past, where he discussed the general accuracy of jacketed 22-caliber bullets. Mr. Hagel was among the most respected and knowledgeable writers in the business. He had far more "hands-on" experience with things gun related than this scribe (and many others) will ever come close to having. In Hagel's experience, the various 50-grain spitzers as well as the 52- and 53-grain hollow-point match bullets outperformed the plain-jane 55-grain spitzers, in everything from the 222 Remington up through the 220 Swift. This has not exactly been my experience, but I recently gave thought to Hagel's somewhat dated information. It piqued my interest to the point that, yesterday, I loaded a number of test rounds using a 50-grain Sierra spitzer in the 223 Remington, 22-250 Remington, and the 220 Swift. In defense of my

own work, however, I have developed quite accurate loads in these cartridges using 55-grain bullets. Additionally, the 53-grain Sierra flat-base match hollowpoint has proven extremely accurate in a couple of 223s and my Ruger 77V 220 Swift. For some strange reason, I've yet to obtain stellar accuracy with this bullet in two 22-250s. I have certainly not sampled every 22-caliber bullet out there. The 60-grain bullets may be worth trying for the handloader who, for whatever reason is not satisfied with the performance of the 55-grain bullets.

If these bullets offer a long-range advantage, it is slight at best. Ballistic coefficients are only very little better than those of the 55-grain bullets. This is offset, however, by a small reduction in muzzle velocity. According to the long-range drop figures, there's not much difference between the two weights. The choice boils down to which bullet is more accurate in a particular gun.

As for a bullet's design style...With all variables in perfect harmony, a spitzer soft-nose, hollowpoint, synthetic-tipped, or an ultra-thin jacketed "blow-up" bullet are all capable of fine accuracy. There is a difference in terminal effect between the four bullet types, but that difference is not so great as to relegate accuracy to a secondary role.



Some older varmint rifles used by the author (left to right): Winchester High Wall 219 Zipper w/12x Unertl, Winchester High Wall 219 Zipper w/10x Unertl, Krag-actioned 219 Zipper w/10x Lyman, Winchester High Wall 22 Hornet w/8x Unertl, BSA Martini 22 Hornet w/4x Weaver.



Modern varminters used by author include (left to right): Ruger M77 MKII 223 Remington w/ 6x Burris, Ruger #1V w/6x Weaver, Ruger #1V 22-250 Remington w/ 6x Lyman, FN Mauser 22-250 Remington w/8x Leupold, and Ruger 77V 220 Swift w/12x Leupold.



Typical 22-caliber varmint bullets, from left: 40-grain Speer, 45-grain Hornady, 50-grain Sierra, 52-grain Speer hollowpoint, 53-grain Sierra Match hollowpoint, 55-grain Sierra, 55-grain Speer, and 55-grain Winchester.



Some "wildcat" varmint cartridges the author has had at least some experience with (from left): 17 Ackley Hornet, 22 Long Snapper (cut-down Hornet), two versions of an "improved" 22 Hornet, 219 Donaldson Wasp, and 22/30-30 Improved.



Varmint cartridges currently used by the author (from left): 22 Hornet, 223 Remington, 219 Zipper, 22-250 Remington, and the 220 Swift.

I have used a fair number of the inexpensive Winchester 22-caliber 55-grain spitzer softpoint "bulk" bullets. Remington markets a similar bullet. They are purchased in quantities of 1000 from various suppliers like Midway. I have not done extensive load development with these, but they display good 200-yard accuracy in my 223s if muzzle velocities are held to around 3200 fps. Accuracy was unacceptable in a 22-250 when velocities were cranked up, however. An old Krag-actioned 219 Zipper shoots the Winchester bullet very accurately at 3000-3100 fps, and it seems to do an acceptable job on coyote.

**Bullet seating depth.** A very important topic. Make up a dummy round and seat a bullet so that it is just barely engraved by the lands. Back off the seating die adjustment

just enough so that the bullet in another dummy round is not engraved. Try a third for confirmation. This cartridge length is not always the best for every firearm and some experimentation may be necessary. However, I always start here and am usually pleased with the results. Sometimes this practice makes for a cartridge too long for magazine use. Is it more important to have a fairly accurate load that will work through a magazine or a very accurate one that precludes use of the magazine? Another choice to make. All serious handloaders have and use micrometers and dial calipers. They should also have a Sinclair Bullet Comparator. This is not a gadget but a useful and inexpensive tool that permits the handloader to make very accurate seating depth changes to a bullet seater. It is used in conjunction with a

caliber. Other similar devices are available, but the Sinclair is the one I am familiar with.

**Powders.** Here again, lots of choices. Many handloaders will already have some suitable powders on hand for the 22-caliber centerfires. Keep those handloading manuals open and compare data again. Find three or four powders that provide acceptably high velocity for the bullet. Many such powders will fill the case or perhaps require slight compression. Published loading data is necessarily and understandably conservative these days. Nevertheless, basic handloading safety is in order. Loads still have to be worked up by starting with conservative charge weights! On occasion, I do find current loading data that is simply too hot for one or more of my firearms.

Each gun is different and that is a fact. At least the experts say it is. Nevertheless, word about an accurate load somehow has a way of traveling around. More often than not, such loads really do shoot well in a variety of guns and they are worth trying. I have done this a number of times with decent success, usually with data gleaned from some firearms publication. Of course, data untested in *my* gun still requires safe starting loads.

Lots of knowledgeable handloaders/varmint hunters live in my part of the world, north central Texas, just south of the Red River. The 222 Remington is remarkably popular in this area. Just about everyone uses the same "accuracy load" consisting of a 50-grain Sierra spitzer softpoint and 20.5 grains of IMR-4198. I checked a couple of loading manuals and this is a maximum load, but apparently a safe one in quite a few local rifles. Sort of makes me wish I had a 222. As a side note, these guys all shoot Sako 222s. I still prefer knowing specifics such as case make, overall cartridge length, and the primer before I start duplicating another's handload.

**Primers.** *With regard to accuracy only*, the primer seems to be the least variable of the loading components. I use standard CCI primers for just about everything, rifle or handgun. I have tried Winchester caps and can't really tell any difference other than a slight velocity increase over the CCI with some loads. I do not imply interchangeability here, though adequate load development for a particular firearm may indicate that one can be used in place of the other. I have used other primers in years past and recall nothing adverse about them. I'm confident Remington and Federal primers work just as well as CCI and Winchesters. Magnum primers are sometimes recommended for certain powders but I have yet to find a need for anything other than the standard model in any of the 22-caliber centerfires, even with ball powders and slow extruded propellants. A word of caution, however: *Do not* work up a load using a standard primer, then switch to a magnum version without working the load up again. The magnum likely will produce a higher chamber pressure than the standard primer. This is extremely important if the load in question is already pushing maximum.

**Brass.** Pretty basic advice, really. Don't mix brass. Buy 100 cases of the same brand. Take care of it and it will last

a long time. Trim brass and turn case necks if necessary. This is more important with the 22-caliber centerfire cases than with any other group of cartridges. Why? Because most handloaders are performance-oriented and high velocity is part of the performance package—particularly with the 22s. We pay a price for this hotrodding, however, in the form of "growing" brass. Cases lengthen. Measure every case after it has been resized. If length exceeds maximum, trim to .010-inch less than the maximum figure. Case necks thicken. The recommended rule for determining a thick case neck still applies and the only measuring device needed is a bullet, just like the one you load in that particular case. If there's insufficient clearance for the bullet to enter a fired case, the case neck is too thick. The neck must be turned, but only enough to provide bullet clearance. Turn a neck too much and the case is ruined for further use. How much is enough? Generally, by "cleaning up" three-fourths of the neck area on a *sized* case, clearance will be about right. This may require some experimentation. Do the entire length of the neck and no more. It is quite easy with neck-turning tools to get into the shoulder area and ruin a case, something most of us have done. Check the loading manuals for the specs on maximum neck diameter, then measure the neck of a loaded round. Unless loads are really hot, neck turning should not have to be done very often. The handloader who turns the case necks of one lot of brass three times has gotten his money's worth and maybe then some. That brass should definitely be discarded. Some people turn case necks as a uniforming operation even if the necks are not too thick. That's fine but unnecessary. I doubt most of us could tell any difference in accuracy, particularly in a rifle with a standard factory chamber. The same can be said for the uniforming of primer pockets.

It is always a good idea to chronograph loads if possible. There are often wide discrepancies between loading manual velocities fired under controlled conditions and velocities that a handloader actually realizes from the shooting bench.

If one has access to a 200-yard range, several groups should be fired at that distance to check both accuracy and point of impact after zeroing at 100 yards. I've found the trajectory figures in the backs of various loading manuals loading to be relatively close to the real thing in most instances. Sometimes they are not. The added piece of mind is worth the extra trouble.

To get into varmint scopes would be outside the scope (!) of this piece, but here's a tip for simple and practical zeroing of a scope on a 22-caliber centerfire. Here is a great revelation: Sight in everything from the 22 Hornet up to the 220 Swift 1-1/2 inches high at 100 yards. With such a setting, holdover is not a concern at any practical range for which the cartridge is intended. That's right, "practical" is a relative term. With my self-imposed limit of slightly over 300 yards on a perfect day, I'm confident my 220 Swift or 22-250 will hit whatever target I happen to aim at, if only I can find a good rest...

Shotgun slugs can be right on target and pack a wallop if you follow these reloading tips.

# Heavy Hitters

By DAVID G. FACKLER

A **QUICK LOOK AT** shotgun slugs will convince the beginner of the great number of choices. So, what works? Perhaps if we stepped back and took a look at the combinations, it might make the choice less complicated.

For years slugs were made of cast lead. The earliest "slugs" used in the Americas were cast lead roundballs that could be loaded into the more delicate flintlock fowling pieces, as well as the sturdy muskets. Both classes of arms were used effectively in 1775 by our patriot forefathers in the Lexington/Concord area while taking on British regulars. Not only did our forefathers take on the regulars, but also severely thrashed them with accurate fire. (*Hezekiah Wyman, 53, of Woburn, MA rode a "strong white mare" to the sound of gunfire. British troops learned to dread the sight of him and the white mare as Mr. Wyman squeezed off shot after shot from ranges of 100 yards and more, along the route between Lexington and Charlestown.*) So we have this early example



Left to right:

1. 20-gauge "Improved Foster" .600"/329gr. Needs wad.
2. Lyman 12-gauge .685"/525 gr. Needs wad.
3. Dimple slug 12-gauge .675"/438 gr. Needs wad.
4. Low Foster 12-gauge .730"/484 gr. Bore snug.
5. Long Foster 12-gauge .670"/660 gr. Needs wad.
6. Plump Rib 12-gauge .738"/757 gr. Bore snug.
7. Dome Rib 12-gauge .728"/480 gr. Bore snug.
8. Dome Smooth 12-gauge .708"/470 gr. Needs (thin) wad.
9. Dome Smooth HEAVY .730"/796 gr. Bore snug.

of cast roundballs being accurately fired from shotguns.

The material used in shotgun slugs was soft pure lead, and often the cast slug might be imperfect, containing voids or impurities that caused flight irregularities. Over the years many shapes of slugs evolved, but some things do not change: the roundball still supplies superior short-range shotgun ballistics. The key to accuracy is a snug fit of slug to the barrel. Some slugs can be a tad "loose" in the crucial fit between slug and bore. When choking became common in shotgun barrels, some slugs were made undersized to minimize choke contact. Undersized slugs may "bounce" in the bore during firing and usually do not deliver consistent groups.

All slugs require range testing to evaluate their accuracy and point of impact and, by firing a number of test loads, the shooter should find the most desirable combination. You want your slugs striking the paper target repeatedly in one small area. Knowing your point of impact allows you to factor "a bit off" into a constant relative aiming point. If you change loads or find a new slug, often your barrel & slug "accommodation" will likewise change.

### Slugs: Cast, Swaged, Pressed, or Milled

Slugs are made by a variety of manufacturing methods. Casting is the oldest method. Today slugs are made by pressure casting and pressure moulding (a combination of mould compression and slurry pressure), or drawn/swaged under compression (no heat, only pressure). Precise slugs are also milled from a continuous lead rod. There are many mixes of materials. What's best? Depends upon your shotgun barrel and situation. Again – test! You must find what works best in your barrel.

### Wad Fit

Another method of providing choke relief is to seat the slug within the petals of a plastic wad. The soft protecting petals allow for a soft squeeze in the choke area; plus, the wad's base seal provides a fine gas check for the propellant. When a slug is made .030-inch or more below the standard diameter of the shotgun's bore, a wad or wrap is used to make up the diameter difference. You cannot have a slug rattling about in a bore and expect repeatable accuracy. Standard bore sizes are: 10 = .775"; 12 = .729"; 16 = .690"; 20 = .620"; 28 = .505" & .410 = (duh!) .410". So if your 12-



Left to right:

1. Brass dome red-rib, 730"/555gr. Bore snug.
2. VITT 12-gauge one piece, .730"/578gr. Bore snug.
3. AQ 12-gauge .735"/392gr. Bore snug.
4. AQ 12-gauge .735"/437gr. Bore snug.
5. Brenneke 12-gauge .735"/478gr. Bore snug.
6. Brenneke 16-gauge .670"/414gr. Bore snug.

gauge slug diameter measures about .700-inch, it should be obvious this slug needs to be tucked inside a plastic shotcup, or wrapped.

### Chokes

Shooting slugs using a barrel with a choke tighter than Cylinder bore may not be working to the shotgun's benefit. Choke constriction, repeatedly hit by heavy slugs, may be damaged. Some projectile designs include thin ridges of material on the widest portion of the slug to facilitate choke passage. Some ridges, cast or pressed (swaged) into slugs, give the appearance of rotational vanes or fins. A slug passing down a smooth bore usually will not rotate. If the vane design permits, the slug may begin rotation when it leaves the barrel. Maybe! But at ranges of 30 to 60 yards, slug rotation is a moot point. Good slug accuracy may be achieved without slug rotation.

### Velocity

We like velocity in most of our slug loads. The old formula is simple – speed kills. Given the choice, velocity usually improves accuracy—and definitely increases lethality. The heavy slug maintains velocity downrange better than a lighter projectile. Thus, a slower launch speed of the heavier slug may produce a higher velocity at impact point. At 40 yards does this really matter? *NO*. The point is to take the animal as quickly and cleanly as possible. Other game besides deer may be taken with slugs... feral hogs, 'gators, bear, moose, caribou, and so forth.



Left to right:

1. .410 roundball on plastic column; .375"/93 gr. Bore snug.
2. 28-gauge roundball; .505"/183 gr. on plastic column. Bore snug.
3. 12-gauge roundball; .690"/487 gr. with typical shot wad.
4. 12-gauge round ball; .715"/550 gr. with typical shot wad.
5. Loaded .715" roundball with roll-crimp.

## Foot Pounds of Energy

Velocity and the weight of the slug factor into a computation called foot-pounds of energy (fpe). At 50 yards, a close range, a slug's loss of velocity/energy is not critical. The energy calculation at launch does provide interesting comparisons between various loads and slugs, as you will see. However, the reader should note the formula is heavily canted to the side of velocity—not mass. And most slugs carry heavy mass to the target!

## Special Slug Loads

The production of special-purpose slug loads is rising. The hunter/angler going into deep wilderness is wise to take along a shotgun and heavy-duty loads (check the rules). Often, *very* large brown bear may be salmon fishing with you! Be prepared; be very prepared with *heavy* slug loads. An American gun writer used 12-gauge slugs to take a Cape buffalo in Africa. He proved his point and is still alive. We tested a 1-3/8 ounce (600-grain) one-piece slug launched from a 12-gauge at 1330 fps. Some loads were a bit faster. The combination of 600gr/1330fps produces an impressive 2360 fpe.

## Other Gauges

There is a 10-gauge Improved Foster type slug that weighs 656 grains (1-1/2 oz.); at 1400fps, it produces 2860fpe. We have tested small-bore high-speed slug loads from the tiny .410 to the 28-gauge. A screaming 28-gauge 5/8-oz. (273-gr.) slug at nearly 1600fps/1550fpe can cause a great deal of damage. A 183-grain roundball from the 28-gauge flies accurately at a screaming 1900fps, producing 1470fpe. The tiny .410 roundball, 93 grains, travels at 1500fps and generates 465fpe; fine for varmint shooting.



Left to right:

1. Two-part 10-gauge hollowpoint; .775"/740gr. (+1-5/8oz.). Bore snug.
2. Very heavy 12-gauge hollowpoint; .720"/814gr. Bore snug.
3. Heavy 12-gauge hollowpoint; .720"/586gr.
4. Heavy 12-gauge French-style Mini-ball slug; .690"/734gr.
5. Very heavy 20-gauge .615"/615gr. (+1-3/8 oz.), or small diameter 12-gauge slug.
6. Heavy 20-gauge; .615"/530gr. (near 1-1/4oz.).

## Tiny Slugs & Large Bores

The 12-gauge and the 20-gauge rifled shotgun bore may be loaded with a plastic sectioned "collet" that looks like a collar with a round pocket in the middle that grips a large rifle bullet. Now, the collet is so named because it has a number of sections that come together to squeeze the bullet and

hold it in place. The unit operates as a sabot but the device, as constructed, also defines a collet.

The collet (bullet) slug is loaded with a jacketed rifle bullet and fired through a shotgun barrel containing rifling. When fired, the collet and the bullet rotate. Since the rifle bullet used is lighter than the usual shotgun slugs, a fast-burning propellant must be used. We have fired Hodgdon TITE-WAD and Alliant BULLSEYE to speed a 45-caliber 300-grain bullet along at 2400fps/3840fpe. It is a very nifty and exciting load combination for the shotgun. The 20-gauge collet with the 250-grain bullet runs at 2200fps/2690fpe.



Left to right:

1. Improved Foster 28-gauge; .510"/273gr. Needs wad.
2. DGS-20 one-piece; .625"/394gr. Bore snug.
3. DGS-16 one-piece, .670"/425gr. Bore snug.
4. DGS-12 one-piece, .735"/498gr. Bore snug.
5. DGS-12 3" one piece, .735"/600gr. Bore snug.
6. DGS-12 sabot, encased, hi-speed, hi-impact; .735"/363gr. Bore snug.

The collet device and bullet measure only a bit over an inch in overall length. A load combination placed in a 2 3/4-inch hull will require a gas seal and filler wads under the collet combination before the roll crimp is applied. The collet device is not recommended for use in smoothbore barrels; without rotation to stabilize the light bullet, there is a tendency for the bullet to get caught in the exit turbulence and tumble.



Left to right:

1. .450"/300 gr. bullet & 20-gauge plastic collet for bullet; for rifled bore.
2. .575"/437 gr. (1oz) bullet & 12-gauge plastic collet; for rifled bore.
3. BRI sabot 12-gauge slug, two-part plastic wrap. Any bore.
4. VHP hollow 12-gauge (interior rotator) with hard plastic seal. Any bore.
5. Sauvestre 12-gauge (factory load) flight slug 390 gr. (7/8 oz.). Any bore.
6. Short 2-inch 12-gauge .715"/1-1/4 oz. ball (BPGS + ball). Any bore.
7. Short 2 1/2-inch 12-gauge; Lyman 520-grain slug (on X12X seal). Any bore.
8. Short 2 1/4-inch 12-gauge collet (12) & 300-grain bullet, for rifled bore.

## Sabots

The use of a slug mounted within a wad technically qualifies the combination as a *sabot* load. The definition of such an arrangement comes out of the French word “wooden shoe” or *sabot*. (If a wooden shoe is utilized to damage fine machinery, the act then becomes *sabotage*.) The thin material of the wad petals provides us with a mini-sabot. Often a shotgun sabot load will have rather thick walls enclosing an elongate aerodynamic slug within the “shoe.”

The “shoe” comes apart in the air and falls to the ground after leaving the barrel. Technically, a shotgun wad provides the same service – just not as extreme in the size ratio of bore diameter to slug diameter. Many fine slugs are designed to fit inside shotshell wads. The typical true sabot/slug design often reduces the sabot/slug-to-bore combination to a 70 percent ratio, sometimes less. Most sabot slug designs interact with both the smooth and the rifled bore. Ah, but which one is best for *your* task? Test-fire, my friend, test-fire.

### The Barrel

The shotgun barrel, most important contributor to accuracy, is made in many forms. A slug-shooter needs a consistent working arrangement between bore and slug.

For many years the double-barreled shotgun was pressed into slug service. But the double has a unique feature of construction known as “barrel convergence.” This point of convergence is unknown to the shotgun’s owner and never described in an owner’s manual. The range of convergence might be... well, anything! When you are dealing with 30-inch shot pattern circles, a centering point may not be identifiable. With slug shooting – *you have to know!* For slug shooting forget about two-barrel shotguns and utilize the single-barrel pump or automatic. Both of these are tube-fed actions. With tube-fed actions make *sure* no tip or protrusion of a slug load extends beyond the crimp top. When slug loads are nested in a magazine tube the tip should *not* project and touch the primer of the next load. If a point peeks out beyond the crimp, an overshot card may be used to further press the slug down into the hull.

With a pump or auto action, one can usually locate a reasonably priced special slug barrel that will improve accuracy. The typical shooting distance for a slug load is about 50 yards—plus or minus. And the target point should be a tiny portion of a deer, about the size of a dessert plate—or smaller.

The end cap on the magazine of pump or automatic shotgun must be snugged down tight. Any movement or pres-



Left to right:

1. Fin-twist .665"/400gr. slug; 16-ga. bore snug; in 12-ga. needs wad.
2. Fin-straight 12-gauge slug; .732"/360gr. Bore snug.
3. Improved Foster set into 12-gauge wad.
4. Fin-twist 20-ga. (HP-Griz); .615"/428gr. Bore snug.
5. Fin-twist 12-ga. (HP-Griz); .735"/550gr. Bore snug.
6. Fin-straight 12-ga. (HP-Griz); .720"/550gr. Bore snug.
7. Fin-twist counter-clockwise 12-ga (HP-Griz); .720"/600gr. Bore snug.

sure change between your chosen slug and your shotgun’s bore induce alignment changes. A shotgun barrel is not a rifle barrel. If the holes you punch in your paper targets wander all over the place, change slugs! Increase or reduce velocity. You may be seeing the dreaded effects of “barrel harmonics”—where the speed and shock of firing creates a slight but rapid movement of the shotgun’s barrel during firing. Lightweight upland shotguns often have thin barrels and are very susceptible to barrel movement.

Do not range-test slugs for accuracy using the off-hand position. A bench with sandbags under the shotgun is the best method to bench-test accuracy. Fiddling about and testing with various slugs is required if you desire accuracy at distance. Once an accurate combination is found with your slug, bore, and sighting system, stay with it.

### Special Slug Barrels

Heavier special “slug” barrels for pumps and automatics have been offered for years. Rifled shotgun barrels have become popular, along with special optical sighting systems. Many of these barrels are already set up for scope and optical systems mounting.

### Spoiled Accuracy

The slug shooter can spoil accuracy hopes by selecting a slug design not suitable for his slug barrel. Slugs designed for rifled barrels should not be used in smooth-bore barrels, and vice-versa. If you have a good working combination, stock up! Nothing is more fleeting in the shotshell component world than the specialized slug. Here today – gone tomorrow. Sometimes more science is added to an existing product, creating a change. As soon as change occurs, retest. And sometimes, good products simply go away.

### Drop

The slug shooter needs to shoot a number of slugs in the testing stage. The objective is to be able to shoot one *good* slug in the field. As mentioned, while testing your shot-





Left to right:

1. Cast 12-gauge dimple-point; .660"/655gr. Needs wad.
2. Cast 12-gauge dimple-point; .690" dia. Needs wad.
3. Cast 12-gauge ribbed, split-point; .675"/522gr. Needs wad.
4. Cast 12-gauge dimple-point; .730"/470gr. Bore snug.
5. Cast 20-gauge split-point; .600"/300gr. Needs thin wad.
6. Cast 20-gauge; .580"/280gr. Needs wad.

gun and slug combination, the shotgun needs to be rested on something solid—such as sandbags on a sturdy shooting bench. Repeated hits in our imaginary grapefruit-sized target from a solid position prove your point of aim—for that distance. Now back off another 20 yards and do the tests again. Repeat. Get to know your slug's drop over given distances. Most slug shooters will miss the target by *over-estimating* slug drop at various distances. And some slugs will *rise* between the end of the barrel and your target for a brief moment! For instance, you may prepare by sighting in at 45 yards, the maximum distance you have ever shot at a deer in your woods. Opening morning, a nice 10-point buck leisurely picks his way across a clearing 70 yards away. Slugs tend to be slow and heavy—so they must drop like a rock, right? You estimate 12 inches of drop at 70 yards—and fire over the back of the deer. At 70 yards drop may be nonexistent, or the slug might even be rising. Slugs may drop a lot less than you expect over a given range. You do have to *know* the trajectory.

### Accuracy

Accomplished slug shooting depends upon your "working range." If your hunting stand produces consistent 20-yard shots—who needs long-range accuracy? However, many slug hunters operate in areas requiring extended range capability. Many slug shotguns are fitted with scopes, or other sophisticated sighting devices. When fitting a sight on a shotgun, make very sure the mount attachments are snug and solid.

All hunters should require an appropriate level of accuracy. Repeated hits in an area the size of a dessert plate—or better, the size of a grapefruit—builds confidence and reduces game loss. Self-assurance becomes a positive match between practice, barrel, slug, aiming system, and the shooter. The shooter must *test* the various combinations of barrel and slug until absolutely satisfied with the result.

### Sights

The "bead" on the tip of the shotgun barrel is a poor slug sight. If your usual shot is 60 yards or *less*—then the bead

may be okay. The experienced shotload shooter has learned to ignore the sighting bead and only "view" the target. At best, double-barreled shotguns are difficult to fit with sights other than the bead. But accurate shooting requires something better. The most positive shotgun sight we have used to date is the type that

brings up a small red dot superimposed upon the target. In general, this type allows one eye to pick up the red dot in the device and the other eye to superimpose the image on the target. The red dot alignment works extremely well for hunting medium and big game.

Think about the tangled woods. You want to place the aim point on a small portion of the target; an aim point that appears as a black post, a black circle or black crosshairs quickly merges into branches and underbrush. The reticle appears no different than some darn twig! Crosshairs in the deep woods—even a center-post reticle—often vanish among the branches. These traditional reticle systems function well in a store with white ceilings and bright lights. But think of the half-light of fall days, the early morning, a drizzling rain! Please, give me the hot red dot!

### Slings

A properly mounted sling greatly steadies a shotgun on the target. A little 'lean' against a tree, with a sling pulled tight, and the 100-yard shot becomes much easier.

A sling—even a temporary rope used as a sling—is a great help in the woods. If your hunt is successful, you find you have a heavy object to drag. What to do with the shotgun? Ah, use the sling! Of course you brought rope along in the backpack for the deer.

### What do we use?

We prefer the DGS type slug—a one-piece unit that includes a gas seal and plastic support column. This slug delivers extremely uniform results, is effortless to load and is accurate in both smooth and rifled barrels.

### Roll Crimping

New, unfired hulls are the easiest to roll crimp. The heat of firing often changes the molecular structure of plastic hull mouths, making them brittle and more difficult to roll over. The spin roll crimp devices are available in all gauges.

Hunting success goes to those who practice and "tune" their equipment. The entire slug season may rest upon one shot—make it good.

When you're  
in pursuit of  
dangerous game,  
it is serious  
business,  
and you had  
better have the  
proper firepower.

# Loads For Dangerous Game

By CHUB EASTMAN

**FROM THE HIGH POINT ON** the ridge with binoculars, we could see the small stand of aspen where our horses were tied. The only thing that separated us was a half-mile of muskeg flat covered by chest-high tangle-foot alder brush. Stretched like a string through the center of the muskeg was a ten-foot cut line pushed through years before by a seismograph crew looking for oil. This was our only avenue to the horses and we didn't have time before dark to backtrack the five-mile circle we had just done.

We knew there was a grizzly down there somewhere. We had been listening to a hell of a donnybrook between him and another bear. Couldn't see them but we could hear the roars, snapping of jaws, and see the bushes shake. A lone stunted spruce tree swayed like a fly rod when one of the bears rolled against it.

We glassed the area for over a half-hour after all the activities had subsided. Not a sound; with flawed logic it was



**No matter what rifle you use when things get interesting it is never big enough. This Cape buffalo finally succumbed to five boiler room shots from the author's Remington 375 Ultra Mag, using 300-grain Nosler Partitions.**

decided we could quietly slip down the cut line to the horses. Darkness was on the way and we didn't want to find our way back to camp after dark.

We had tiptoed half way across the cut line with neither of us saying a word when all of a sudden a loud "whoof" broke the silence and a huge black form rose like an elevator 15 feet in front of us. Two beady black eyes bored a hole through me like a bolt of lightning. My pucker string snapped so tight I bit my tongue and couldn't breathe.

There was no time to think the situation out; it was pure reaction as both rifles went up. Nothing but black hair in the scope, then *bang, bang*. As I cycled the next round into the chamber, I sensed the empty case had hit the ejector on my Model 70 so hard that it was still in orbit.

Dead silence, not a sound except for the breeze rustling through the brush. At the shot the bear had simply disappeared and we couldn't see over the brush to where the bear was standing when we shot.

The adrenalin was so high it was hard to move but reluctantly we separated about 10 feet and ever so slowly moved to where the bear had been. After about five steps we could see the top of a black form lying motionless in front of us. As we moved cautiously forward we understood the reason for the fight with the other bear. My bear fell right on top of a moose carcass he had obviously claimed.

As we skinned the bear we performed a crude autopsy

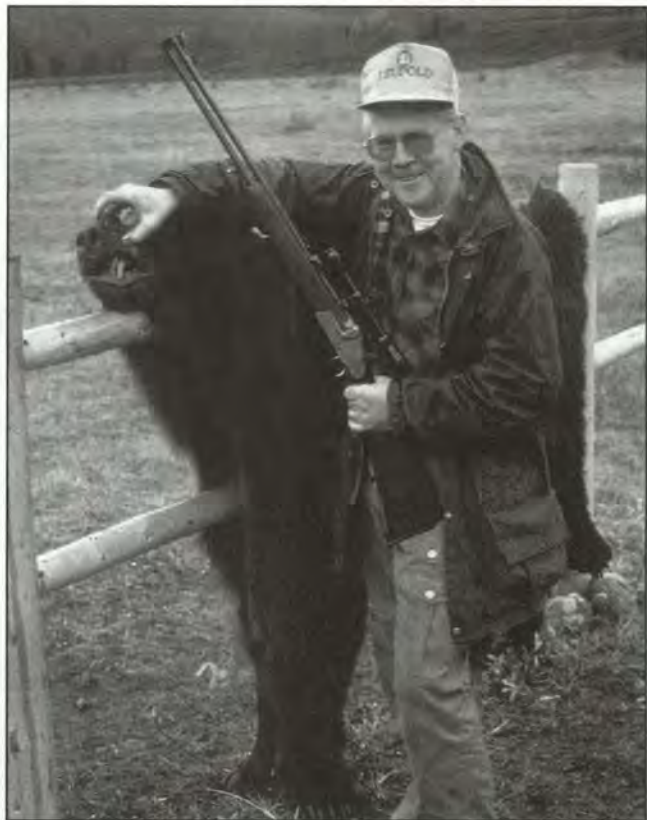

**Lars-Olof Swanteson with his beautiful mountain grizzly. One shot from his 9.3x64 o/u Krieghoff using the 286-grain Brenneke bullet anchored him quickly. Mounted life-size, this bear now greets customers at Swanteson's sporting goods store in Sweden.**

to see what had happened. My 210-grain Nosler Partition from the Mod. 70 338-06 had centered him in the chest, hit the heart and lungs, and severed his spine. The bullet was in the hide between the top of his shoulders. The guide's 150-grain Nosler Partition from his trusty Ruger 77 in 270 Winchester had entered the chest 1-1/2 inches from my shot and traveled no further than the heart/lung area.

We were lucky, very lucky. Had the spine not been hit, the few seconds that bear would have had left could have been more than exciting. For him to cover the distance between us would have only taken a nanosecond. I doubt the second round was chambered fast enough to have been much use.

The lesson learned: The next time this could happen I will have a rifle big enough to let daylight through the bullet hole. The guide's rifle had better be at least as big as mine, or he walks 10 paces in front.

Whether the pursuit of dangerous game is the number one priority or you are in an area where dangerous game lives, your choice of a firearm is serious business. You had better not only pay attention to your environment, but also have the proper firepower to quickly settle any situation.

The only really dangerous game we have in North America are the big bears found in the upper wilderness of the northwestern states and north as far as the Arctic Circle. These are critters with an unpredictable disposition that would have no qualms about adding you to the menu.



**Author and hunting partner Craig Boddington with big and nasty Australian water buffalo. Author downed this bull with one shot from his 416 Weatherby Magnum using a 400-grain Nosler Partition.**



**Craig Boddington with bad-tempered Australian scrub bull. Two shots from Boddington's 500/416 Krieghoff double rifle stopped him in his tracks at short range.**

In most cases when dangerous game is the subject, the first thought is the Big 5 of Africa. The only one of the Big 5 that is smaller in actual size is the leopard. Most adult male leopards rarely exceed 180 pounds in weight and are less than a foot through the boiler room. He is still as mean as—and even more cunning than—the other four if not shot properly. Precision shot placement is a must. Most are shot close to 50 yards from a blind over bait.

A standard hunting rifle using a well-constructed soft-nose bullet will dispatch a leopard quickly. If your shot placement is a little off, there is a good chance your adrenaline level will hit overload in a hurry. A wounded leopard will usually not go far before it finds a place to ambush the one that hurt him. When the charge comes, there is no sound and he gives no warning. Make the first shot count.

The other 4 of the Big 5—Cape buffalo, white rhino, lion and elephant—are big, mean, and take great delight in pounding you into the ground or pulling you apart, especially if wounded.

What is needed for the big dangerous game is a rifle/cartridge that will deliver as much foot-pounds of energy as you can shoot accurately. A 460 Weatherby is a great cartridge that has enough power to knock a rail car off its tracks, but if you can't put the bullet where it belongs each time, all it does is make a dangerous critter start looking to see what disrupted his day.

In most countries of Africa where dangerous game is



**Fellow scribe Brian Pearce proved that big well-constructed bullets are best for big animals. The 400-grain cast bullet from his Marlin 45-70 broke both shoulders of this tough zebra.**

hunted, the minimum chambering for the big guys is, by law, the 375 H&H. Here in the states we usually consider the 375 H&H a big rifle, unneeded in most cases. To the experienced professional hunter in Africa it's considered a medium bore size. A rifle is not considered a big bore until it exceeds 40-caliber.

The three things that are a must when pursuing dangerous game are shot placement, foot-pounds of energy, and bullet construction. To a point, the same holds true when hunting any big game; but with dangerous game it is essential to your health that all three come together as best you can.

Years ago, the first time I put crosshairs on a Cape buffalo bull the P.H. was excitedly whispering in my ear "Break him down, break bones". As soon as the front legs collapsed and his nose stuck in the dirt the next instruction was "Shoot him again". Preservation of meat is not as important as keeping him anchored on the ground.

This goes for any dangerous game. You try to destroy the vitals if possible—but it's better if you break major bones along the way. They can move faster on four legs than they can on two or three, and it doesn't make any difference which two or three it is. I had an old-time P.H. tell me "Don't stop shooting till they quit kicking". That's maybe a little overstated, but something to think about. You still want to take the air out of them and stop the pump as you would with any big game, but with dangerous game you also want to destroy as much muscle and bone as possible.

There is a book titled *The Perfect Shot* written by Kevin Robertson that should be required reading before any hunter heads for the Dark Continent. In his book Robertson gives pictures and overlaid anatomy illustrations that show not only where the bones are but, as well, the position of vital organs in the body. Understanding the anatomy of the animal you are pursuing gives you a great advantage in knowing where to put your first shot.

Energy is what delivers the knockdown punch, breaks bones and destroys muscle tissue. There is no substitute for it. A big bullet at a moderate velocity is what's needed to penetrate the inch-thick hide, and bones as big as your forearm, before getting to the boiler room.

Energy is the combination of velocity and bullet weight. Even though some cartridges generate high velocity with small bullets and deliver impressive fpe, their bullets lack the sectional density to break major bones and still penetrate through the vitals. The other advantage of bigger bullets is bigger holes, which relates directly to more damage.

Bullet selection is the third key to your success. You get myriad answers when you talk to experienced hunters and P.H.s. Soft-nose or solid is always a subject for discussion and rarely is there 100 percent agreement. Elephant is the only animal on the dangerous game list where most all agree on the solid being the best choice.

The advantage of the solid is that it usually will not deflect or distort when bone is hit, and penetration is deeper than any other type of bullet. The disadvantage that is wound channels are very small, and tissue damage is reduced con-



Any of these rifles will do for dangerous game. (L/R) Winchester Mod. 70, 375 H&H; Custom Mod 70 9.3x64 Brenneke; FN Browning 458 Win. Mag. and Krieghoff Double 375 H&H Flanged.

siderably. On more than one occasion I have seen where a recovered Barnes solid looked just as it did when it came out of the box. If it wasn't for the rifling marks scored on the bullet, it could be reloaded a second time.

Other manufacturers, besides Barnes, offer solids in their line. Woodleigh, Hornady, Speer and A-Square are just a few. They all work; it's just a matter of what shoots best in your rifle. Use caution when reloading solids, as some have no lead in the core. Follow the manufacturer's reloading guide, as data for solids may be different than conventional bullets. If the bullet is solid bronze or copper, there is a definite chance for dramatic pressure spikes as loads are increased. There is no 'give' in the solid bullet as there is in a bullet with a copper jacket and soft lead core. Solids will not damage the bore, as some say, as long as directions are followed.

If you need a demonstration as to how solids work, just line up a bunch of water-filled plastic milk jugs and see how many you can shoot through. Then do the same thing with your soft-nose load with an equal weight bullet. The results are interesting and impressive.

The one thing all experienced hunters agree on when it



**Some experienced African hunters prefer a double rifle to a bolt action for the speed of the second shot. Rifle shown is author's Krieghoff side-by-side 375 H&H flanged, with quick-detachable scope mounts and fixed iron sights.**

comes to soft-nose bullets is they have to be tough, retain as much weight as possible and be heavy enough (sectional density) to plow through a big-boned nasty critter. The bullet also has to create a channel of destruction you can stick your fist in.

As demanding as these criteria sound, there are many bullets out there that will fit the bill. The Swift A-Frame, Combined Technology Partition Gold, FailSafe, Federal Trophy Bonded, Nosler Partition, Woodleigh Weldcore, Barnes-X and Norma Oryx. Smaller manufacturers, like North Fork Technologies, also make excellent bullets for dangerous game.

The biggest decision you have to make is which shoots the best in your rifle. There is plenty of loaded ammunition out there that uses most of the above bullets. However, you do have an advantage if you are a handloader. The bullet selection is much greater and you have the ability to tailor the load to your rifle.

If you are headed for Africa, there is one thing worth mentioning that might prevent a real problem. Chamber pressure and heat are not a good combination. Most of the older big-bore cartridges, like the 416 Rigby and some of the large Nitro Express cartridges, were loaded to keep pressures below 50,000psi. The reason was the potential sharp rise in chamber pressure caused by excessive heat. A strong suggestion is not to exceed the loading data given in the bullet manufacturers' manuals. The data given in all the manuals are safe in most all rifles in good condition and are developed to give the maximum performance for each given bullet/powder combination.

After you have developed the load best suited for your rifle, buy new cases or use once-fired cases for the ammunition you are going to take on the hunt. When assembling the loads, try to use powder from the same container or powder

with the same lot number. Same goes for the primers. Sometimes there is a slight variation in burning rate from one lot to the next. This could have an effect on accuracy and point of impact.

When you are finished loading the ammunition destined for the hunt, take the time to cycle each round through the magazine. Doing this ensures each will feed and chamber properly with no tight spots or hang-ups. That's the last thing you want to have a problem with. If you don't, rest assured Murphy's Law will prevail when you come nose to nose with 2000 lbs. of meanness and a second or third shot is needed in a hurry.

With any big-bore rifle, or any rifle for that matter, you have to be proficient not only in accurate shot placement but also in loading and unloading the rifle. The only way you gain this proficiency is with practice, practice—and more practice. Not from a bench on the firing line but from normal shooting positions you would encounter in the field. If you can keep all your shots inside a pie plate at 100 yards, you are good to go. The ammo you burn up in practice is a small price to pay for success.

There is more than one reason a PH or guide/outfitter wants you to shoot your rifle on arrival in camp. Making sure the rifle is sighted in is the usual reason given to have you sit down and send a round or two down range. The other reason – just as important to them—is to see how you handle and operate your rifle. Practice enhances familiarity so the function of your rifle becomes second nature and you don't have to think each time you put the rifle to your shoulder.

One thought that's a little off the subject but worth mentioning is traveling with firearms and ammunition in today's environment. Security checks at airports, border crossings and customs have become a near nightmare since 9/11. Strict new rules and regulations prevail and you should be aware of each before you throw your gear in a gun case and head for the airport.

All airlines require you to declare any firearms and ammunition at the ticket counter. There is quite an inspection process you have to go through and ammunition should be packed in a separate bag. Check with your airline to get the regulations, as each is a little different.

Same with customs and local regulations if you are traveling outside the U.S.A. Your booking agent or guide/outfitter should be able to tell you what to expect. The last thing you want is a problem when you and your equipment are traveling together.

To make your hunt successful there is a lot of preparation and research that should be done. Murphy's Law and nasty surprises are things you do not need during any phase of your adventure. Ask questions and make sure all your bases are covered before you walk out the door.

Most importantly—take your rifle and practice, practice, practice. The last thing you want is to look like a greenhorn when you arrive in camp. It makes PHs and guide/outfitters real nervous. Good hunting.

When handgun silhouette exploded into the shooting scene in the mid-1970s, it became very apparent from the beginning that it was going to be a reloader's sport.

# Reloading for Slamming Steel

By TODD SPOTTI

**THE REQUIREMENTS OF** this particular competition were way beyond what anyone had ever demanded from handgun ammunition before. Let's spell it out. The basic goal of the game is to not only hit, but also to knock down 40 steel targets which are roughly life-size representations of ten chickens (50 meters), ten pigs (100 meters), ten turkeys (150 meters), and ten rams (200 meters). The rams particularly represented a knotty problem to those early handgunners. Because of their size, they weigh about 50 pounds, and because of their distance, any handgun bullet fired at them will have run out of a lot of steam by the time it got out to 200 meters.

Think of it: 200 meters is the rough equivalent of two complete football fields laid out end-to-end, including a set of end zones. Besides weight and distance, another factor limiting knockdown performance was that almost all of those early competitors were using revolvers—simply because

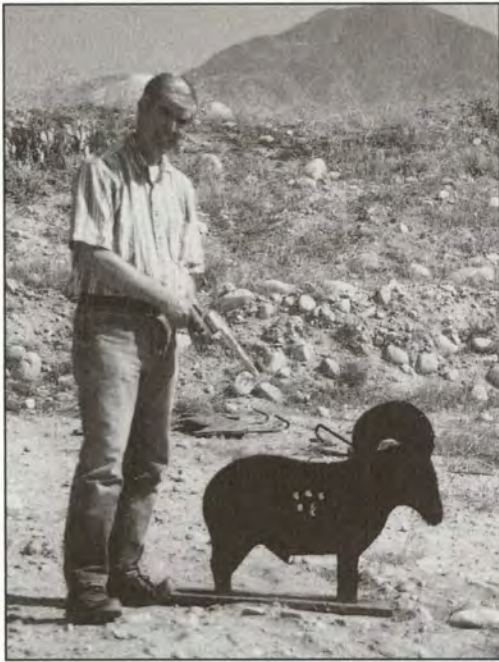

Author with a Dan Wesson 41 Super Magnum and a 200-meter practice target.



Author practicing on a 50-meter chicken targets.



Specialty products such as Redding's competition seating and profile crimping dies provide a high level of performance need when reloading competition quality ammo.



The Dan Wesson (top) and Freedom Arms (bottom) revolvers are good examples of firearms designed specifically for silhouette competition and handgun hunting.

that's what most shooters happened to have readily available. Then there's the issue of accuracy. They can't fall if you don't hit them.

Unfortunately, the factory revolver ammo available back then was just not suited for this new game. The 357 Magnum stuff was usually loaded with a 158-grain bullet or lighter. Shooters quickly discovered that 158 grains wasn't enough to reliably take down the rams—or sometimes even the 100-

meter pig targets. Even the mighty 44 Magnum with its 240-grain swaged lead bullet was iffy because it was often loaded fairly slow by the factory to avoid leading the barrel.

Additionally, as silhouette shooters gained more experience in the sport, they also realized that the jackets on factory-loaded bullets were too thin, being designed primarily for self-defense purposes and rapid expansion. When these thin-skinned bullets hit a heavy metal target, they fre-



quently would break apart before they could deliver their full momentum, or "push," onto the target. The end result was that the steel animal wouldn't fall, and the hit couldn't be counted in the total score. Consequently, "Damn ram" became a common expression in those early days.

Well, as they say, things have changed. First of all, there are the pistols. Back then, there were just a few suitable handguns available to the sport. Now, there are a wide variety of pistols to select from: revolvers, break-open actions, falling block actions, and even bolt actions. The bullet situation has also changed in that there are now plenty of heavy-jacketed, specialty silhouette bullets readily available. Additionally, because of the growth of interest in handgun hunting, which I believe is a direct result of the fact that handgun silhouette clearly proved how powerful and accurate a handgun can be, bullets like Hornady's XTP have been designed both for deep penetration as well as controlled expansion on game. As it turns out, these new bullets are perfectly suitable for animals made either of solid steel or flesh and blood.

The sport of handgun silhouette itself has also changed quite a bit since those early days as well. There's a much wider variety of competition "categories" available to appeal to shooters with different needs and interests, including scoped categories that can accommodate those of us with aging eyes. But when you boil it all down, it comes down to two types of silhouette guns: revolvers and single-shot pistols with either 10 1/2-inch or 15-inch barrels. Both types, obviously, have very different reloading requirements.

### Loading for Revolvers

A popular comedian made a very successful career telling people how he didn't get any respect. The same might also be said of revolvers. Most people have a tendency of lumping revolvers into the category of fairly inaccurate self-defense weapons used primarily at close range; i.e., around 10-12 feet, or certainly no more than 25 yards. Indeed, the majority of revolvers today actually fall in that category. However, there are notable exceptions. They are the revolvers that have been designed from the ground up as being suitable for hunting and silhouette. They are primarily those from Freedom Arms, Dan Wesson, and to a lesser extent from Ruger and—more recently—Smith & Wesson. Reloading match-winning revolver ammo is more demanding than any other type. However, careful attention to detail and use of quality reloading tools can result in significant rewards. I've personally shot sub-one-inch groups with Freedom Arms 357 and 44 Magnum revolvers at 100 yards. I've also had 1 1/2- to 1 3/4-inch groups from Dan Wesson revolvers at the same distance. Indeed some of today's revolvers are as accurate at 100 yards as many bolt-action rifles of the last generation.

The lowly brass case is the one revolver component that gets the least amount of respect, yet it is the one that that will demand the most of our time if we want to put together match winning loads. Talk to a benchrest shooter and I guarantee you will be amazed how much time and effort will



Sorting cases by weight is the traditional method for ensuring consistent results.



Sorting brass by neck thickness helps ensure the bullet be well-centered in the case and crimping more uniform.

go into their case preparation efforts. In fact, once a set of cases are fully prepared, the benchrest shooter will use them over and over, sometimes even for years. While the silhouette revolver competitor doesn't have to go to the same lengths as a benchrest shooter, they do have to use some benchrest type techniques to get the best results.

First you want to assemble your revolver loads using only the best cases in a given lot of brass. So how do you determine which ones are the best? The traditional method of evaluating brass quality is to weigh the individual cases. This is a good indication of the consistency of the internal



Standard reloading manuals and the *IHMSA News* are resources that can be easily used to obtain reloading data for silhouette wildcat cartridges.

volume of the case. Heavier cases will have thicker sidewalls and less internal volume; conversely, lighter cases will have thinner sidewalls and more internal volume. Ideally then, we'd like to have cases where all have the same internal volume since variations in volume/weight in a given lot of brass would translate into pressure variations. That in turn will translate into velocity variations and larger groups.

Another criterion for determining the quality of your competition revolver brass is to measure the uniformity of the thickness of the case wall at the mouth. Ideally, we'd like brass that has exactly the same thickness on all sides of the case. However, that's never going to happen because of normal production variations in materials and processes. The end result is that when a bullet is seated, it's not going to be perfectly centered in the case, but rather will be pushed off to the side by the thicker wall toward the thin side of the case. The end result is that the bullet isn't perfectly aligned with the bore when the gun is fired, even if everything else is perfectly lined up.

In the past, this wasn't an issue as the manufacturing tolerances in revolver barrel/cylinder alignment was often generous. Sometimes, it is very down right sloppy. However, current high-quality revolvers, like those mentioned above, provide exceptional barrel/cylinder alignment to the point that bullet/case alignment actually does now become a factor in producing top accuracy. Consequently, you want to measure and select cases in which the differences in the thickness of the sidewalls are minimized.

After the cases have been measured and sorted for weight and case wall consistency, it's time for the trimming operation. This is extremely important for revolver brass; however, I doubt if one in 10,000 revolver shooters will do it. The reason this is so important is that the case length of revolver brass can vary significantly. This difference in case length will determine the amount, or "hardness", of the

crimp. Longer cases will be crimped harder than shorter cases. Consequently, some bullets will be held in the case more firmly than others and will offer more resistance to moving under the pressure of the burning powder. Bullets offering more resistance to movement will allow pressure to build just a bit longer than bullets offering less crimp. This situation will translate into velocity variations and larger groups.

Now for the sizing operation. Since the die manufacturers have to make dies that can accommodate all the revolvers ever made for a given cartridge, most sizing dies squeeze the case sidewalls down way too much. This often results in loaded cartridges literally rattling around in the cylinder chambers. The end result is that the bullet/case will not be aligned properly with the revolver's forcing cone and accuracy will be diminished.



Some typical examples of silhouette wildcats and their parent cases. (Left to right) 221 Fireball, 300 Whisper, 223 and 7mm TCU.

Ideally we want the case to be minimally sized; just enough so it can be easily inserted into the chamber once the bullet has been seated. One way to accomplish this goal with regular sizing dies is to just size the top 1/3 of the case and leave the bottom 2/3 with the same dimensions as it had after it was fired. This is easily accomplished by backing out the sizing die in the press and screwing down its decapping pin far enough so that the spent primer can be reliably punched out. With such a case, the sized top 1/3 will firmly hold the bullet, and the bottom of the case will better fit the chamber and result in improved case alignment.

Now it's time to bell the mouth of the case, an easy and straightforward operation. This is necessary to seat the revolver bullet into the case without damaging its sides.



There are only two things to keep in mind. One is you don't want to overdo it. Spreading the mouth of the case open puts a lot of stress on the brass. Over time, this will result in work-hardening followed by case-splitting. To minimize this, you want to open the case mouth only enough so that the bullet will sit on top of the case with no support and with the sides of the case not projecting beyond the sides of the bullet.

**A good example of a perfectly belled case where the sides are not excessively bent away from the bullet.**

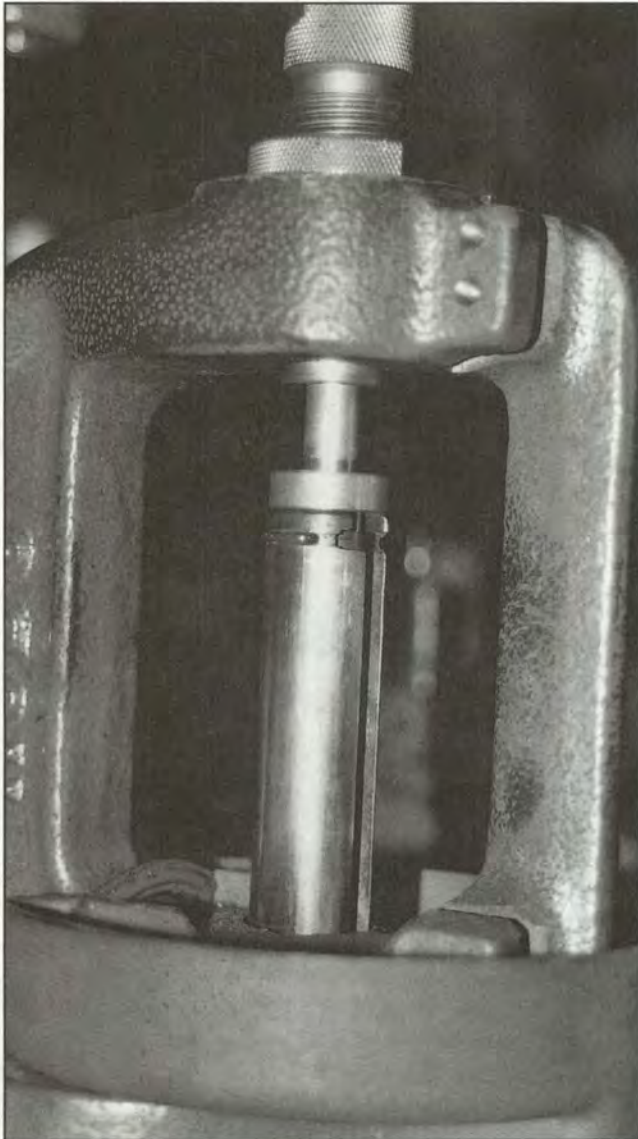

**Partially sizing revolver brass will often allow a better fit in the chambers.**

The other thing to keep in mind is not to chamfer the mouth of the case prior to belling. Many reloading manuals will tell you to chamfer both the inside and the outside of the mouth. The purpose of the chamfer is to make sure any burrs on the mouth will be removed so they can't scratch the bullet as it's being seated. However, since the case mouth is being bent away from the bullet in the belling operation, this isn't a problem. I don't recommend chamfering because it will generate a thin, near knife-edge shape at the top of the case mouth with very little metal left to grip the

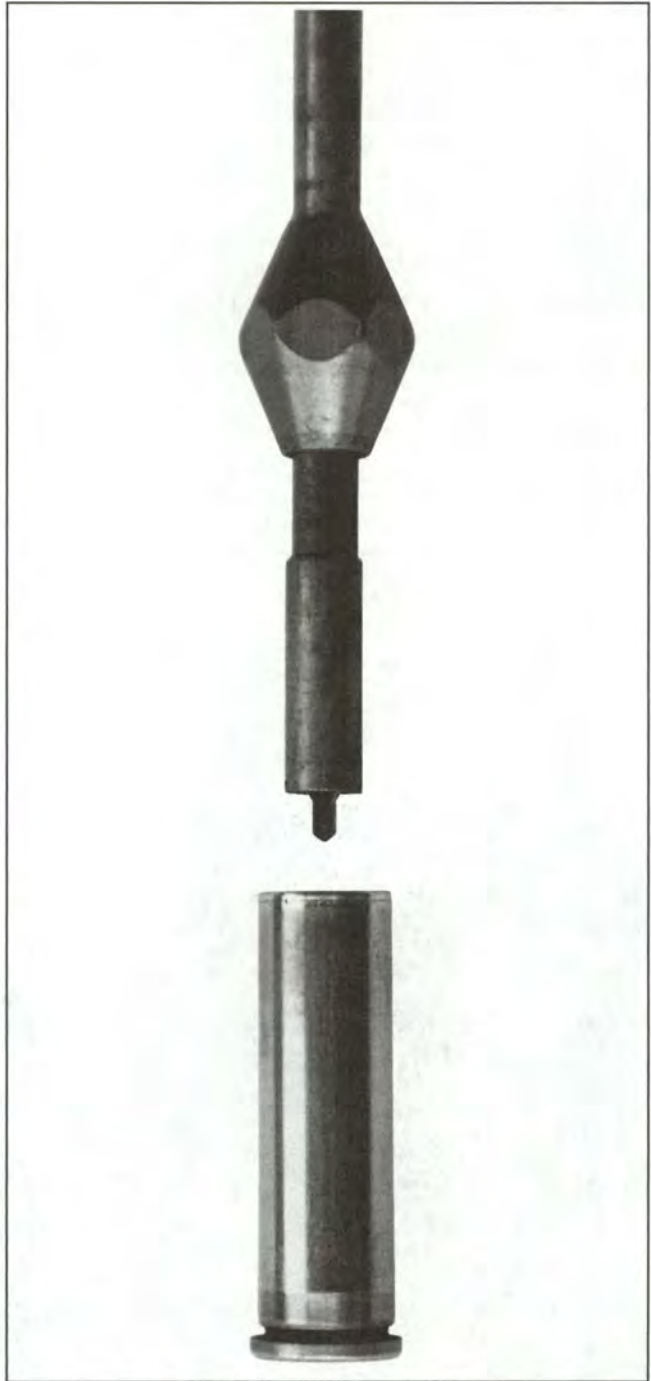

**Uniform flash holes ensure consistent primer patterns.**

cannelure of the bullet during the crimping operation. During the crimp, we want all the metal that's available to ensure the strongest result.

Now we have to pay some attention to a couple of areas of the revolver case that are commonly ignored by probably 90 percent of all shooters; i.e., the primer pocket and the flash hole. All benchrest shooters will both uniform the case primer pockets and the primer flash hole. Indeed, the serious revolver shooter will do the same. The idea behind uniforming the primer pocket is to ensure the primer is seated perfectly against a flat and even surface, and at the same depth in every case. If a primer is seated poorly in an irregularly-shaped primer pocket, it could actually be moved slightly forward by the blow from the firing pin. Ignition of the powder would likely be irregular as a result and the placement of the shot unpredictable. Uniforming pockets ensures the primer will be perfectly seated and will deliver best results every time.

Uniforming the primer flash hole also serves the same purpose. If you look inside a revolver case, you'll often see a ringed burr or ridge around the flash hole. This ridge will usually vary slightly from case to case. As a result, the shape of the flaming primer material flowing through the hole can also vary from case to case. By using a uniforming tool to cut away this burr, the primer flame pattern should be more consistent.

Just as with any other precision ammunition, bullet seat-

ing for revolvers is very important. If the bullet is off-center in the case, accuracy will suffer. First of all, don't slam the bullet into the case. I've seen reloaders in a hurry just throw a bullet on top of a case and then really whip their press handle down hard in their rush to get the next case into the press. As a minimum, safety demands that reloading should not be done in a rush. Accuracy also requires a deliberate approach.

Almost all seating dies do a perfectly adequate job of seating the bullet. However, when reloading competition quality ammunition, we want the very best in bullet/case alignment. When using regular seating dies, place the bullet in the case mouth in as much as a vertical a position as possible. Bring down the handle on your reloading press part way so that the bullet is seated approximately 25 percent of the way into the case. Back off, and then rotate the case 180 degrees. Now seat the bullet all the way into the case. If there is any degree of misalignment between the die and the shellholder, rotating the case as described will help to minimize it. To assist in this case-rotating procedure, you might want to make a little index mark on the side of the case with a magic marker and two index marks on your shellholder 180 degrees apart. Just align the case mark with one of the shellholder marks and then rotate the case to the opposite shellholder mark.

Another more precise and accurate option is simply to use a competition pistol seating die from Redding. This die is manufactured to more exacting dimensions than your run-

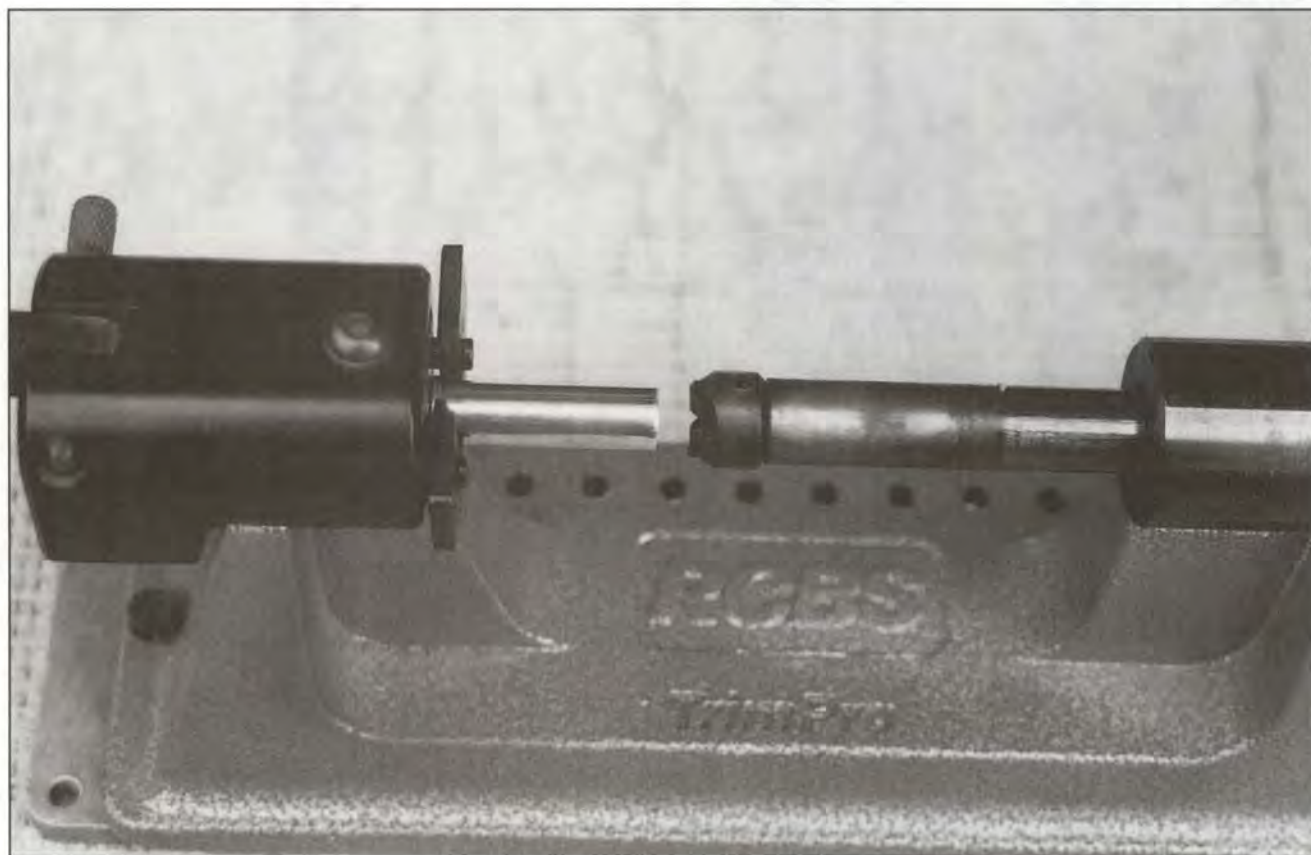

Trimming revolver brass to a uniform length is essential to fine accuracy.



The 10.5 MOA falling-block pistol (top) and the break-open action Encore pistol are typical examples of production category silhouette guns.

of-the-mill seating die. It also uses a spring-loaded seating stem to keep the case and bullet in the best possible alignment with each other. Additionally, it has a micrometer head to ensure bullet-seating depth can be repeated precisely. Use of this die is faster, more convenient, and more accurate than the case-rotating method, but it is more expensive and does not crimp the case. Crimping must be accomplished in a separate operation.

As mentioned before, crimping is very important to revolver accuracy. When using a standard combination seating/crimping die, it's a good idea to rotate the case 180 degrees once more after bullet seating to ensure the crimp is uniformly applied on all sides of the case (don't go overboard on the crimp). A good crimp will roll the case mouth firmly against the center of the bullet's cannelure. Use a test case and bullet when adjusting the die to achieve this result. If you see the case mouth is being flattened against the bullet, you've gone too far and now are damaging it. I guarantee that the case mouth will start developing splits before too long.

For the best crimp, I use the Redding profile-crimping die in a separate operation from the seating process. This die applies a combination of a taper crimp, which is usually found on semi-auto pistol ammo that headspaces on the mouth of the case, and a standard roll crimp. The combination of these two types of crimp on the same bullet really locks it in place. This ensures the bullets in adjacent chambers absolutely will not move—even the biggest magnum revolvers are under recoil.

One last point on revolver reloading for silhouette competition. Roll-crimping puts tremendous stress on the mouth of the case and work-hardens it. As a result, the ability of the case to uniformly hold the bullet will be diminished with each use and eventually the brass will start to weaken and eventually split. Consequently for the very best in accuracy, you probably don't want to use a case more than five times in competition. After that, it can be used for practice or for casual shooting.

### Reloading Single-Shot Pistols

For the most part, reloading for single-shot silhouette pistols is actually easier than reloading for revolvers. When using a standard cartridge like the 7 BR, 223, 30-30 etc., normal rifle reloading techniques as described in the standard reloading manuals work just fine.

However, most silhouette shooters prefer to use a wildcat cartridge of one variety or another. Wildcats can often offer advantages to a pistol shooter that a standard cartridge can't, i.e., higher velocities, lower recoil, economy, etc.

Most wildcats favored by silhouette competitors can be formed very easily.

The 6.5 BR, the classic 7mm TCU, or the 300 Whisper are good examples. In these situations, a readily available parent case (7 BR, 223, & 221 Fireball) is lightly lubed and run into the full-length sizing die for the desired cartridge. This process will then change the diameter of the mouth (expand/reduce), and sometimes the shoulder angle of the case will be changed as well.



This 15-inch Unlimited Class bolt action carries a 2-8X scope to do load testing.

If you're shooting a bolt gun, like the Remington XP-100 or the break-open Encore pistol, you want to set up the full-length sizing die a little differently for the best result. Back it off a couple of turns from the bottom. Then run a lubed case through. The shoulder will probably be too far forward for the case to chamber in your gun, but try it anyway. Gradually turn the die down in small increments, which will slowly move the shoulder back, step-by-step. You want the die to keep pushing back the shoulder until the case will just chamber in your gun when using only modest pressure on the bolt or when closing the Encore. The reformed case is now firmly fitted to the chamber. Remember, you don't want the action to close with great effort or with no effort. You're looking for something in the middle.

For trouble-free functioning, it's best if the brass chambers easily in the older model Thompson Contender pistols. So just follow the standard adjustment instructions provided by the die manufacturer. The reformed case is now loaded and fire-formed to fit the dimensions of the wildcat chamber of the gun.

Now there has been a lot of mumbo jumbo floating around about fireforming. Many reloaders will fire-form wildcat cases by using a small charge of a fast-burning pistol powder, such as Bullseye or Unique, and then fill the rest of the case with a fine-grained filler material—a popular breakfast cereal, or perhaps cornmeal. The case will then be plugged with wax—sometimes even toilet paper—and then fired. It's true that this procedure will blow the case out to exactly fit the wildcat chamber. However, it's totally unnecessary. Just prepare the case with a standard safe load, and

fire. The case will also be perfectly formed to the desired dimensions without all the added trouble of putting together special loads for this purpose. Accuracy won't be affected, either. Plenty of silhouette competitors have shot perfect scores in competition, using regular loads when fireforming at the same time.

I've also discovered a possible downside to this practice of shooting dry, hard cereals down your barrel. They're abrasive. On a hunch, I loaded up my vibratory-type case cleaner with the wheat cereal, and then threw in a dozen or so dirty 357 Magnum cases. Several hours later the cases were nice and shiny. Not as shiny if I had used standard walnut tumbling media, but shiny enough. If the cereal is abrasive enough to polish brass, blasting it through the bore of your expensive firearm under high pressure probably isn't doing it a lot of good. Just use regular loads.

One last issue. Where does a novice find safe loads for silhouette wildcat cartridges? Actually, the standard reloading manuals are full of well-tested, proven loads. They are the absolute best source. Another good source is the *IHMSA News*, the official newspaper for the International Handgun Metallic Silhouette Association—the primary sponsoring organization for silhouette competition in the United States. Technical articles with load info are a standard feature in almost every issue and loads used by championship winners are often published as well.

With just a modest investment of time and attention to detail, match-winning loads are available to anyone. Follow these guidelines and you'll be slamming steel with the best of them. Good luck and good shooting.

Careful, consistent reloading practices pay off for popular NRA Action Pistol, IPSC and USPSA contests.

# Reloading for Handgun Competition

By STEVE GASH

**INTEREST IN HANDGUN** shooting has always been strong in the United States and is accomplished safely by countless millions of stalwart citizens annually. In addition to good old-fashioned plinking, recently this interest has evolved into a plethora of specialized games for handguns, and to do well, it is imperative that you get into some kind of organized competition.

The more popular contests are the NRA Action Pistol matches, and "practical pistol" events of the International Practical Shooting Confederation (IPSC) and the United States Practical Shooting Association (USPSA). Hits in IPSC are scored based on the "power factor" (PF) of the ammo. The PF of a load is the weight of the bullet (grains) times its velocity (feet per second) divided by 1000 (**Table 1**). In IPSC, a PF of 165 is considered "major," and 125 is "minor". For NRA Action Pistol, all loads must have a PF of 120 or higher.

In IPSC, with a "major" power load, hits in the "A" zone are 5 points, those in "B/C" 4 points, and "D" hits are 3 points. With a

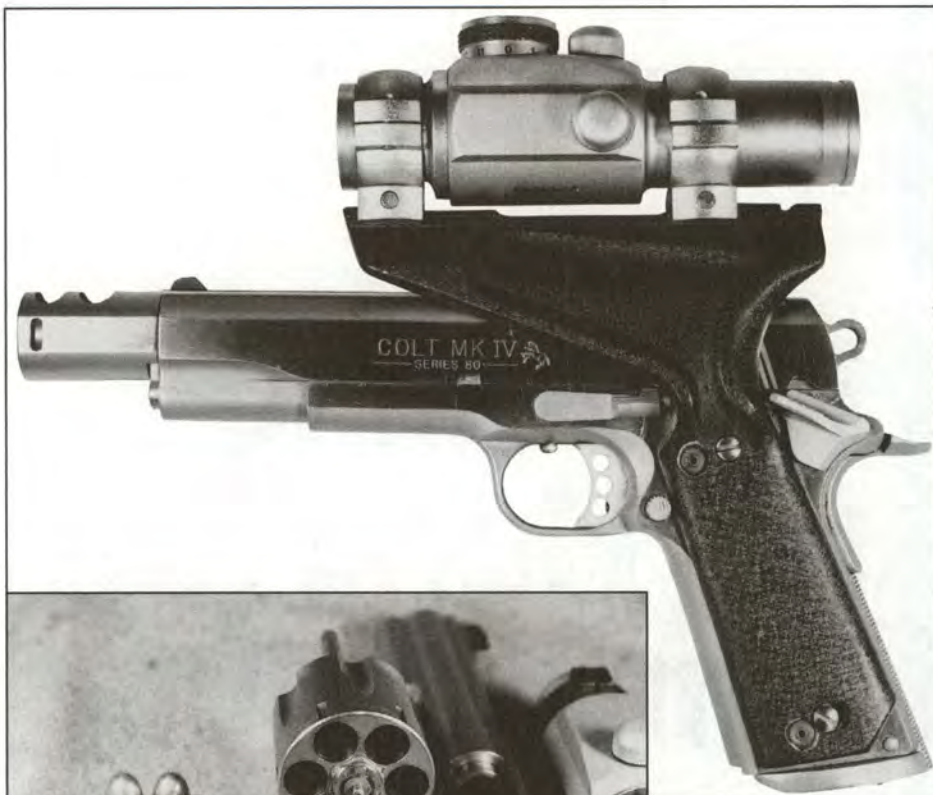

Colt M-1911 stainless Government in 45 ACP, modified by the author with the addition of a Tasco PDP3 dot sight, Clark grip mount, Videki adjustable trigger, and Clark Comp-Kit 5.5 in. barrel with compensator.

major load, and the shooter can get back on target a bit faster saving a few precious tenths of a second.

### Reloading Ammunition For Competition

Let's face it. For us mortals of modest means, to shoot well means to shoot a lot, and the only way to do that is to reload your own ammo. Sure, some loads shoot better in a particular gun than

others, but generally speaking, just find a good tried and true load, sight your gun in for it, and stick with it. Just make sure you reload with care and attention to detail to avoid misfires and squibs that will get you disqualified or injured.

Let's start with components. In general, after you pick a load, you should always buy components in bulk. This way, you aren't always running out, you'll accrue significant savings by quantity buying, and you won't inadvertently be switching production lots of powder and primers every few thousand rounds.

You will note that in **Table 2**, cases are frequently identified only as "mixed". This is exactly what they are. We have all heard the oft-repeated mantra to "sort your cases..." For rifles, fine, but for competition handguns I never do. It's just



S&W M-625 in 45 ACP.

minor power load, the point values for zones A, B, and C are 5, 3, and 2 points, respectively. Minor load shooters will quickly point out that if you just make "A" zone hits, then power factor doesn't matter. This is a prescient message. Also, a minor load doesn't recoil nearly as much as a



Clips come in an array of calibers, here a 6-shot 44 Special from Clark, an 8-shot from Miles, and a 6-shot 45 ACP from Ranch Products.



A Lee 1000, a batch of components, and you're ready to load 'em up in quantity.

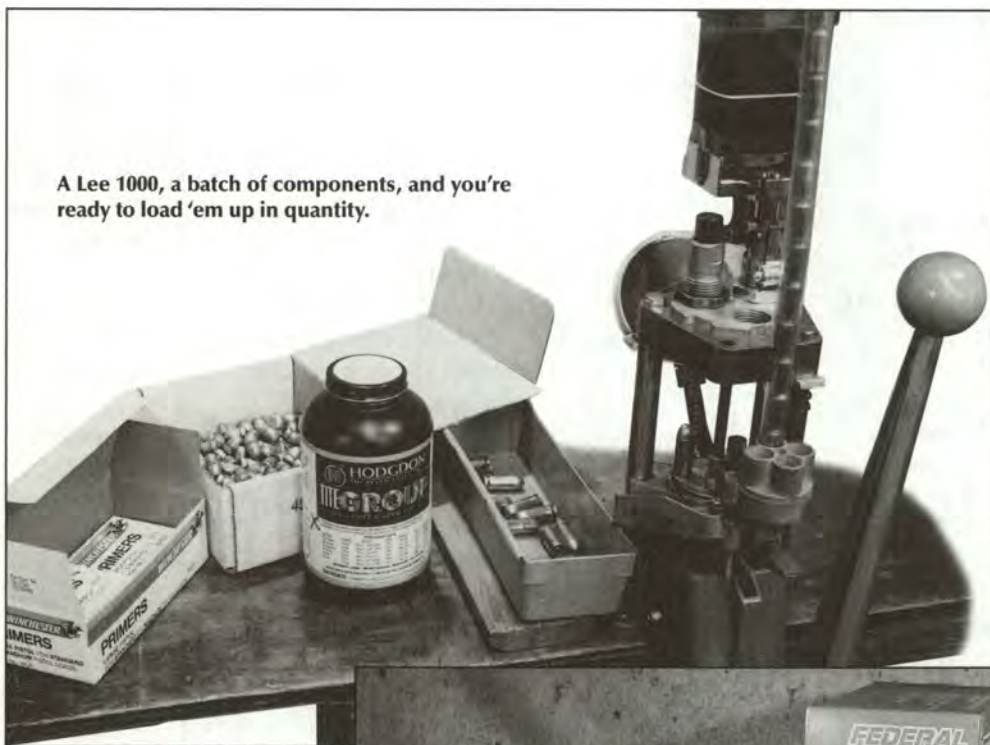

flake powder is also very clean-burning, as is Alliant's American Select.

Probably the two most used pistol powders of all time are Alliant's Bullseye and Winchester's 231. Both meter uniformly and produce great accuracy in a vast array of handgun loads. You'll see both mentioned frequently in the accompanying load table.

There are a couple of other Winchester powders that fill load-specific niches. Winchester recently discontinued its Super Lite (WSL) powder, but like many other

too time-consuming, and I've never found that it makes any practical difference. The handguns themselves are accurate, but remember -- we're still the nut behind the trigger, and a "loose nut" far overshadows any slight effect of a difference in cases.

Let's dispense with a few other reloading sacred cows while we're at it. Do I trim pistol cases? Nope. Do I clean their primer pockets. Are you kidding? Do I weigh cast bullets? Not a chance! If any of this makes one whit of practical difference in a match, it has yet to be demonstrated to me. Life's too short to put up with such drivel.

As for primers, I use most major brands with complete satisfaction. My favorite primer brand overall is Federal, although in autos, I use a lot of Winchester caps.

Today's reloader has a great choice of powders from which to choose, and many were developed with the volume loader in mind. The best powders for handgun competition loads are those that use a low charge-weight. This gives you more rounds per keg. Ball or spherical powders, or other small-grain powders like Bullseye, Power Pistol, Universal, Clays, etc., meter uniformly and give trouble-free loading. I haven't found a caliber yet that doesn't like Hodgdon's new Tite-Group powder, but I keep looking. It is position insensitive (important with small charges in big cases), burns cleanly, and seems to be accurate in everything. Hodgdon's CLAYS

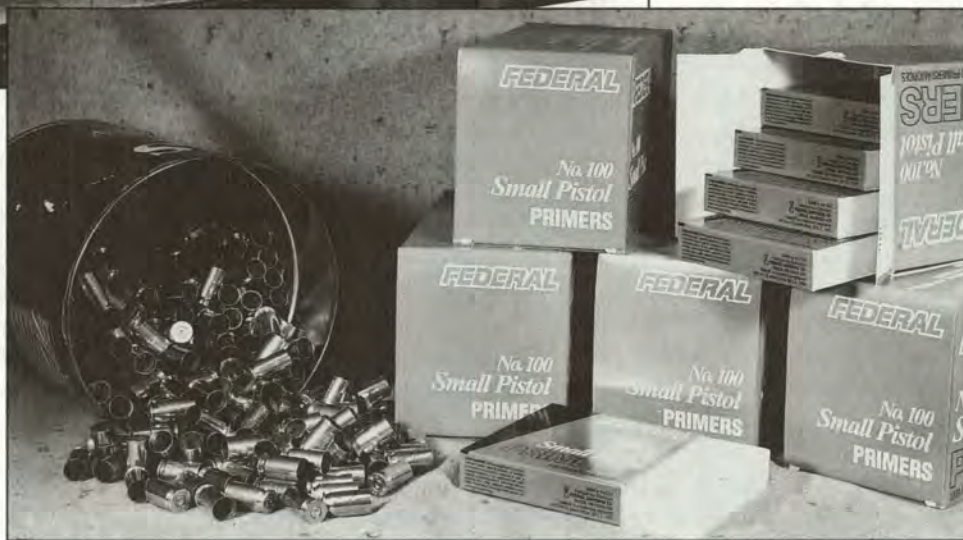

Competition ammo requires components in volume, like these primers and cases.

powder hogs, I have hoarded a goodly supply of it, and I still occasionally see it on dealer's shelves. It is similar in burning rate to W-231, and is a great powder for light-to-moderate loads. Winchester Super Field (WSF) powder is slightly slower, and a bit more specialized. I use a lot of it in 40 S&W, and a few other calibers. For those who lament the loss of Winchester's Action Pistol Powder (WAP), fear not. Silhouette powder from Western Powders, Inc. is the exact same thing.

As for bullets, this is easy: stick with cast bullets for all but the most specialized loads for two reasons. First and foremost is economy. Buying good cast bullets in large quantities (like 5000 and up) saves you significant change. Compared to jacketed bullets, cast bullets are about half the price, or less. The other reason is that cast bullets won't wear out your barrel as fast as jacketed bullets. About the only disadvantages to cast bullets are smoke from the lubricant



A great variety of cast bullets are available, and here are several 9mm designs that are proven winners. Buying large containers of powder saves money and helps consistency of competition reloads.

used on them, and barrel leading—but these are minor compared to their advantages.

Anyone reloading for competition pretty much has to use a progressive loader. There are lots of progressive loaders out there, but I think it would be safe to say that two firms dominate the field: Dillon Precision and Lee Precision. Dillon makes a wide variety of progressive loaders, from hobby-oriented to the professional level. Their Model 550 is probably the most popular. They're all quality machines. Lee makes two progressives, the Pro 1000 and the Load Master. Personally, I use several Lee 1000s, and they serve my purposes well. (*I have learned to ignore the derisive snickers I get from Dillon users.*) What kind of progressive loader you have is less important than whether or not you have one.

Most progressive loaders perform virtually all loading functions with one pull of the handle, but we can tweak the procedure a bit for better results. Just about all loaders use a carbide sizer, but some folks like to size and prime cases separately, and that's okay—if you have the time. I sometimes do this for 45 ACP, but not usually.

One slight modification to the loading procedure that pays big dividends is to seat and crimp the bullet in separate operations. Just adjust the seater/crimper in your progres-

sive loader so that it doesn't touch the case mouth, and seat to your desired overall length (OAL), then apply the crimp. The best tool for this job is what Lee calls its "Carbide Factory Crimp Die." This little gem sizes the entire cartridge after it's loaded, and puts on the appropriate crimp, either roll or taper. After sizing in this die, ammo will work in just about any gun, and accuracy is usually improved. They are available for all popular calibers.

Be sure and check the OAL of your cartridges for fit in your gun. OAL is often critical for the proper functioning of an auto pistol, and it's not impossible to get revolver rounds too long for the cylinder.

Let's talk accuracy for a minute. While everyone wants a gun that shoots one-hole groups, most guns don't. Besides, to be competitive in a match, you really don't need that level of accuracy. For example, if you can keep all your shots in an 8-inch circle, you will score 100 percent in the Bianchi Cup match. The loads reported here shot 1.0- to 1.5-inch groups with optical-sighted guns, and 2.0- to 2.5-inch clusters with open sights at 25 yards.

Finally, be sure to chronograph your ammo in your gun, and adjust the powder charge as needed to achieve the desired velocity and PF. Match officials will usually chronograph contestants' loads, and you don't want to get disqualified for under-powered ammo.

## Gun Specific Loads For Competition

Loads for the six most popular cartridges are discussed below, and are listed in Table 2. Load data for six additional rounds that see use in competition are also shown in Table 2. I have personally used all of the loads listed in the table at one time or another. They are the best I've found for each caliber.

### 9mm Luger

**Test Gun:** CZ model 85 Combat auto, 4.7-inch barrel

The ubiquitous 9mm is used frequently these days in NRA Action Pistol and in IPSC limited class. It is just about impossible to "make major" with the 9mm, so don't even try. Besides, with light-recoiling minor power loads, "A" zone hits are readily attainable. For a great shooting load, try a 122-grain flat-point (FP)—also called truncated cone



9mm cases and bullets. Shown here (from left): a 122-grain FP and the 9mm Luger; a 125-grain RN and the 9x21; a 145-grain RN and the 38 Super; and a 147-grain FP and the 9x23 Winchester.



9mm cases – the long and short of it. (From left): the 9mm Luger, 9x21, 38 Super, and 9x23 Winchester.

grain bullet, either a SWC or a RN. A charge of 3.5 grains of Bullseye, 4.3 grains of W-231, or 3.3 grains of TiteGroup produces at least 860 fps, and are good minor power loads. I use SWC bullets the most, but the RN version is almost as accurate, and speed-loads faster.

In days of old, if you had a Smith & Wesson K-38, you had a gem, and they are still a fine choice.

(TC), or a 125-grain round-nose (RN) bullet ahead of a modest charge of a fast-burning powder like Bullseye, WSL, W-231, or TiteGroup. In my CZ-85, a charge of 4.7 grains of TiteGroup produces a velocity of 1094 fps, for a PF of 133.5 – plenty for any PF-rated contest. Best of all, it shoots “A-zone” groups. Also try 3.6-grains of WSL, which is even milder at 1024 fps. A more powerful heavy-bullet load uses a 145-grain RN with 3.4 grains of TiteGroup. Velocity is 1001 fps, with a plate-stomping 145.1 PF. This load shoots well in my Browning High Power, too.

### 38 Special

**Test Guns:** Taurus M-608 revolver, 6.5-inch barrel

Everybody’s favorite accuracy cartridge, the age-old 38 Special is used in all types of competitions. I frequently use 38s in a Taurus M-608 357 Magnum for matches. In this big, heavy gun, recoil is nil, recovery time is fast, and accuracy is top drawer.

It’s pretty much a given that 38 Special loads use a 158-

Revolvers in 38 Special are not as popular as they once were, but if “all you have” to shoot in competition is a 38 Special, do not despair. Remember, it will easily make minor PF, and the recoil is so modest that “A” zone hits are easy. Shoot it, and be happy.

### 38 Super

**Test Guns:** Smith & Wesson M-627 revolver from the Performance Center, 5.5-inch barrel; custom Colt M-1911 auto, 5.5-inch barrel.

The old 38 Super has made a modest comeback in the past few decades, and for good reason. It is powerful, accurate, and reliable. Many IPSC shooters stoke it to the max to make major – and most of the time succeed without blowing up their guns. New hardware for the old round is now available in either autos or revolvers. The S&W M-627 PC is the epitome of wheel guns, and is match-ready from the box. In the auto line, Kimber offers their “Stainless Target II” auto in 38 Super, and a few other firms offer the Super in autos



38-calibers reign. (From left): a 38 Special case, a 125-grain FP and RN, 158-grain RNFP, SWC, and RN, and a 357 Magnum case.

as well.

The 8-shot M-627 I tested was super accurate, and could be Speed-loaded with the full-moon clips almost as fast as a M-625 45 ACP which, as any seasoned wheel-gunner will tell you, is pretty darn fast. In the Super, the 122-grain FP bullet over 4.6 grains of Universal makes a great load for NRA Action and most other events. At 1144 fps, it has an adequate PF of almost 140, and at that velocity it reduces the amount of lead required on the mover. With the 125-grain RN bullet, 4.2 grains of TiteGroup easily makes minor at 1095 fps, has low recoil, and is a fine all-around load. If your gun favors an SWC bullet, try 6.0 grains of Vihtavuori N-350 for 1182 fps. This is also a great NRA Action load, and especially good for the mover. For a heavy bullet major power load, the 158-grain RN with 7.6 grains of AA-7 was very accurate at a velocity of 1182 fps with a PF of 173.3; this is plenty for most any action match. For a match load for autos, my pal Jens Barclay, who is NRA Master Class in Action Pistol, has tried just about everything and has settled on the aforementioned 122-grain FP and 4.6 grains of (*what else?*) TiteGroup. I tried his gun and ammo at an NRA match, and it was indeed super. Velocity is 1190 fps, and PF is 145.2. It's a great NRA load, and pure death on the falling plates.

### 357 Magnum

**Test Gun:** Taurus M-608 revolver, 6.5-inch barrel.

Our first magnum cartridge was introduced in 1935, but until recently, not too many shooters used it in competition. As the "revolver-only" crowd grows, its use has skyrocketed, and about all you now see at such events are 8-shot 357 Magnums, either S&Ws or Tauruses. Virtually all use full-moon clips, either from the factory (*S&W*) or in guns modified for their use (*Taurus, and others*). I have for years used the Taurus M-608 8-shot 357 Magnum so modified in NRA Action Pistol, and I don't think it gives up much to the "bottom-feeders" (*autos*).

For all-around utility, you can't go wrong with the standard 158-grain cast bullet. For years, I have relied on two basic loads: 4.5 grains of W-231 with the SWC bullet for a velocity of 898 (141.9 PF), and 4.4 grains of WSL with the RN version for 914 fps (144.4 PF). Both shoot under an inch at 25 yards, have ample power for the falling plates, and have sufficient speed for the moving target event. I have shot many thousands of these two loads, and you can't go wrong with either of them.

A happy compromise is the new round-nose flat-point bullet (RNFP) used by the cowboy action shooters. In my M-608s, this bullet with 4.4 grains of WSL shoots almost as well as the WC, and speedloads almost as fast as the pure RN. It, too, is a good all-around load.

Speed merchants will want to try 125-grain bullets at 1100+ fps. With cast bullets, the RN over 6.4 grains of W-231 or the FP with 6.2 grains of WSL offer about 1124 fps, a PF of 140, and great accuracy. Hornady XTP jacketed hollowpoint bullets seem to shoot great in any caliber, and

the 357 Magnum is no exception. For a time I used the 125-grain XTP with 6.7 grains of W-231 in NRA Action Pistol. At a velocity of 1124 fps, it shoots great, and it reduces the lead required on the mover. The increased muzzle blast and recoil of these high-velocity loads probably outweigh their advantages, however, so in the final analysis, it is probably best to stick to the slower and heavier cast bullet loads.

### 357 SIG

**Test Guns:** Springfield Armory XD auto, 4-inch barrel; Smith & Wesson M-4006, Bar-Sto 4-inch barrel.

I had an S&W M-4006 in 40 S&W when the 357 SIG was introduced in 1994, and it dawned on me that I could just swap out the barrel and have a 357 SIG. The nice folks at Bar-Sto Precision took care of that, and the testing began. Then in 2002, Springfield Armory started offering their XD model in 9mm, 40 S&W and – you guessed it – the 357 SIG. I immediately obtained one, and it has become one of my very favorite handguns. It shoots great, and never hiccups. I have used it in a couple of local matches, and it shoots like a dream.

Like a spoiled child, I have a warm spot in my heart for the 357 SIG. It combines high power and great accuracy in one compact package. Despite the name, the 357 SIG is a true 9mm, with a bullet diameter of .355-inch. This little bottlenecked number slithers into the chamber like a greased pig. The case is basically a necked-down 40 S&W, although the SIG case is .015-inch shorter, so don't try making your own cases out of 40s. Starline sells super-quality 357 SIG cases, and there are lots of fired cases for sale.

Seasoned reloaders may blanch at the sight of a bottlenecked pistol round that has to be lubricated before sizing, but this really isn't an issue. Just lay out a bunch of cases on an old towel, make sure they're all on their sides, and give them a light shot of one of the spray lubes. Roll them over a bit, another light shot of lube, and you're done. Let the lube dry, and size away. The lube remaining on loaded ammo isn't really a problem, either; I usually don't even wipe it off, and everything works fine.

Since the 357 SIG headspaces on the shoulder, not the case mouth as you might think, use caution when setting up your sizing die so you don't set the shoulder back too much. As long as a sized case will drop fully into the chamber, you should have no problem. Many companies make dies for the SIG, but I particularly like the Redding dies I have. They are a 3-piece set, with a separate expander. This allows you to bell the case mouth for ease of use with cast bullets. The Redding seating die puts a nice taper crimp on finished rounds. I've never had a bobble with a 357 SIG reload.

The 357 SIG is actually a fun cartridge to load, and it's even more fun to shoot. For a cast bullet load, you can use the 125-grain SWC bullet for just about everything. In the XD, 5.0 grains of W-231 is about as good as it gets. Velocity is 1072, with a PF of 134 -- plenty for most any minor venue. To spice things up a bit, you might try 7.3 grains of WAP for a velocity of 1231 fps. This is a very good high velocity



The 40 S&W with (from left): the 180-grain FP, 185-grain RN, and 200-grain FP bullets, and a 10mm Auto case on right.

load for the 357 SIG -- but it's still minor. In the S&W M-4006, 5.4 grains of Universal was my match load for years. It's hard to beat. In fact, almost any load in a 357 SIG is a winner.

### 40 Smith & Wesson

**Test Guns:** Para-Ordnance P-16 Limited auto, 5-inch barrel; Smith & Wesson M-4006, 4-inch barrel.

If ever a cartridge took the shooting world by storm, it was the 40 Smith & Wesson. And contrary to some comments, "S&W" doesn't stand for "Short & Weak." The 40 can hold its own in just about any corner.



Even though the 40 S&W and the 10mm Auto have the same case and bullet diameters, they use different size primers.



The 44-calibers are not without their fans. Here are (from left): a 44 Special case, 180-grain FP, and 200-grain RNFP, and the ever-popular 240-grain SWC. A 44 Magnum case is at right.

I used the M-4006 in its original 40-caliber guise in matches for years with only the 200-grain FP. With 5.9 grains of AA-5 at 898 fps, or 5.2 grains of Unique at 914 fps, it was a major powerhouse. Recoil was a bit grim in the 39-ounce pistol, however.

After I had the M-4006 converted to 357 SIG, I started using the P-16 in limited class matches. The P-16 is a full-sized 5-inch barreled M-1911 pistol with plenty of weight and accuracy. It serves the "10mm short" well. In it I mostly use the 180-grain FP bullet and 3.3 grains of WSL. This produces only 735 fps, a PF of 132.3, itty-bitty groups, and very little felt recoil. A "wimp" load? You bet. I love it. When I need a major power load for the P-16, I use 4.7 grains of WSF and the 200-grain FP bullet for 861 fps and major power at 172.2.

### 45 ACP

**Test Guns:** Colt M-1911 auto with 5.5-inch Clark Comp-Kit barrel; Colt M-1911 Combat Elite auto, 5-inch barrel; Smith & Wesson M-625 revolver, 5-inch barrel.

Just about everybody's favorite auto is the Colt, or a clone of the Model 1911. They are made by many companies, and are available in steel or alloy frames, in many barrel and frame lengths, with or without compensators, mounts for optical sights -- well, you get the idea. The 45 ACP probably sees more use on the match circuit than about any other cartridge. Not only is it accurate, it can be loaded to about any desired power level, and inexpensive components are everywhere.

For an all-around good load, one need look no further than the ubiquitous 200-grain SWC bullet, and a keg of W-231. Work up to the Winchester-listed load of 5.5 grains for a velocity of (at least) 850 fps. With a PF of 170+, you're in business. Legions of 45 fans shoot their entire careers of "combat" matches with only this load.

I have used a variety of loads in my 1992-vintage Combat Elite, but now stick with just three. I really like the 175-grain SWC over 4.8-gr. of WSL, for 810 fps, or 4.2 grains of Bullseye (765 fps). Accuracy with either is A+. My (current) favorite load uses the 185-grain SWC and 4.9 grains of WSL. At 766 fps, it is plenty powerful (at a PF of 142), and accurate, especially at longer ranges. I use this combination in an annual match where the ranges extend to 35 yards. I

## Table 2. Match Ready Reloads For IPSC and NRA Competition

Caliber	Test Gun	Bbl. Len. (in.)	Case	Primer	Charge Powder	Bulle (gr.)	Weight Type	Bullet Vel (grs.)	Power (fps)	Factor	Comments
<b>9mm Luger</b>	CZ 85 Combat	4.7	mixed	WSP	TiteGroup	3.7	FP	122	1094	133.5	NRA, IPSC minor load
					WSL	3.6	RN	125	1024	128.0	same, mild recoil
					TiteGroup	3.4	RN	145	1001	145.1	good heavy bullet load, minor
<b>38 Special</b>	Taurus M-608	6.5	mixed	WSP	Bullseye	3.5	SWC	158	903	142.7	traditional accuracy load
					W-231	4.3	SWC	158	860	135.9	very accurate
					TiteGroup	3.3	SWC	158	886	140.0	great NRA load
<b>38 Super</b>	S&W M-627 PC	5.0	S-L	Fed 100	UNIV.	4.6	FP	122	1144	139.6	NRA mover load, IPSC minor
					TiteGroup	4.2	RN	125	1095	136.9	minor, good all around load
					VV N-350	6.0	SWC	125	1182	147.8	good NRA Action load
					AA-7	7.6	RN	158	1097	173.3	good major power load
					Colt M-1911	5.5	mixed	WSP	TiteGroup	4.6	FP
<b>9x21</b>	custom CZ 75	5.25	S-L	WSP	WSL	4.4	SWC	125	1128	141.0	all 3 loads minor, but all
					WAP	5.6	SWC	125	1117	139.6	are very accurate
					P.P.	6.0	SWC	125	1180	147.5	
<b>9x23</b>	Colt M-1911	5.0	S-L	WSP	WAP	6.4	FP	147	1200	176.4	major power IPSC load
					HS-7	8.2	FP	147	1169	171.8	major power IPSC load
					WAP	6.6	Sierra	150	1168	175.2	accurate, no lube smoke
					UNIVERSAL	5.8	Sierra	150	1177	176.6	very accurate
<b>357 Magnum</b>	Taurus M-608	6.5	R-P	Fed 100	W-231	6.4	RN	125	1124	140.5	great NRA action, mover load
					WSL	6.2	FP	125	1125	140.6	good load, very accurate
					W-231	4.5	SWC	158	898	141.9	great NRA action load
					WSL	4.4	RN	158	914	144.4	minor power tackdriver
					W-231	6.7	Hor. XTP	125	1122	140.3	great NRA/mover load
<b>357 SIG</b>	Sptg. XD	4.0	S-L	WSP	W-231	5.0	SWC	125	1072	134.0	great limited class load
					WAP	7.3	SWC	125	1231	153.9	good high velocity load
	S&W M-4006	4.0	S-L	WSP	W-231	4.5	SWC	125	1006	125.8	minor, good plate load
					UNIVERSAL	5.4	SWC	125	1105	138.1	great minor power load
<b>40 S&amp;W</b>	Para-Ord P-16	5.0	mixed	WSP	WSL	3.3	FP	180	735	132.3	my favorite wimp load!
					WSF	4.7	FP	200	861	172.2	IPSC major power load
	S&W M-4006	4.0	mixed	WSP	AA-5	5.9	FP	200	898	179.6	good heavy bullet load
					Unique	5.2	FP	200	944	188.8	IPSC major power load
<b>10mm Auto</b>	S&W M-1006	5.0	PMC	Fed 150	Blue Dot	8.1	Sierra	180	1040	187.2	high power load, no lub smoke
			Win.		UNIVERSAL	4.5	FP	200	898	179.6	major power, very accurate
	S&W M-610	5.0			W-231	6.4	SWC	215	856	184.0	very accurate revolver load
<b>44 Special</b>	S&W M-624	6.5	Win.	Fed 150	Red Dot	4.5	FP	180	755	135.9	minor, accurate
					TiteGroup	4.5	FPRN	200	745	149.0	this bullet speedloads fast
					Red Dot	3.3	SWC	240	575	138.0	low velocity, but accurate
<b>45 ACP</b>	Colt M-1911	5.0	mixed	WLP	Am.Select	6.0	SWC	155	1072	166.2	NRA/mover, IPSC major load
					Bullseye	4.2	SWC	175	765	133.9	great all around load
					WSL	4.8	SWC	175	810	141.8	IPCS minor, bullseye
					WSL	4.9	SWC	185	766	141.7	great for longer ranges
					W-231	5.5	RN	200	886	177.2	good RN bullet load
	S&W M-625	5.0	mixed	Fed 150	Unique	5.3	RN	230	813	187.0	good heavy RN bullet load
					CLAYS	3.4	RN	200	715	143.0	IPSC minor load
					WLP	7.3	RN	200	890	178.0	IPSC major load
					TiteGroup	3.4	RN	230	637	146.5	great 230-gr. minor load
W-231	4.7	RN	230	760	174.8	IPSC major heavy bullet load					
<b>45 Auto Rim</b>	S&W M-625	5.0	R-P	Fed 150	W-231	5.3	WC	244	850	207.4	super power bowling pin load

CAUTION: The loads listed above were safe in the author's guns, but may not be in yours. Reduce the charges of the heavier loads by about 6%, and work up, watching for signs of excessive pressure. DO NOT reduce the lightest loads (for either cast or jacketed bullets) due to the danger of sticking a bullet or a jacket in the barrel.

Abbreviations: FP, flat point; P.P., power Pistol; RN, round; S-L, Starline; SWC, semi-wadcutter; WAP, Winchester Action Pistol; WSF, Winchester Super Field; WSL, Winchester Super Lite.

have used the standard "combat" load noted above, but it kicks a bit more than I like, and I get back on target faster with the 175- and 185-grain loads.

With the Clark Comp-Kit barreled gun, I use a slightly higher velocity load for NRA Action Pistol. The stubby 155-grain SWC over 6.0 grains of American Select clocks out at 1072 fps, and is very suitable for NRA Action Pistol match, with enough velocity to reduce leads in the moving target event.

This load technically makes the new major power factor at 166.2, but I wouldn't trust my entry fees to it except on a hot day. However, it is very accurate, and the compensated barrel cuts muzzle flip considerably. It's a bit specialized, but it works. The 175-grain SWC/4.8-grain WSL load shoots well



Accuracy like this is all you need to be competitive in a match. These groups were shot with a Taurus M-608 in 357 Magnum. Load: 4.2 grains of Tite-Group and 158-grain SWC bullet.

An ammo mix-up can be serious. This is what happens when you fire a 10mm round in a 45 ACP. Luckily, neither gun nor shooter was damaged.



Keep good records and label your ammo boxes.

in both guns. A good major power load with the traditional 230-grain bullet is 5.3 grains of old standby Unique for a velocity of 813 fps and a PF of 187.

If you shoot an M-625, here is where the reloader can simplify his life considerably. If you can find a load with either the 200- or 230-grain RN bullet that shoots well in your auto and your M-625, you can use it in both guns, and reduce your load inventory. In my experience, for a dual-gun load, the 230s seem to shoot a little better than the 200s, but try 'em both in your hardware.

For years, my standard M-625 load has been 3.4 grains of CLAYS and the 200-grain RN bullet. It is truly a one-holer, and has a reassuring PF of 143. If you want to stoke the 200s up to major, try 7.3 grains of WAP for 890 fps and a PF of 178. It shoots very well, but again, I didn't like the recoil. Remember: make A-zone hits, and it doesn't matter. For a super-accurate 230-grain load, try 3.4 grains of Tite-Group. At 637 fps, and a PF of 146.5, it's a great load with low recoil.

Back in my younger days, when I thought that you'd be drummed out of the corps if you didn't shoot major in everything, I used the 230-grain RN over 4.7 grains of W-231 for a velocity of 760 fps, and a PF of 175. This load is certainly one worth trying in either an auto or a revolver, as it is very accurate.

## Conclusion

Well, there you have it—a compendium of reloads that virtually any shooter can use as a springboard to NRA Action Pistol or IPSC practical pistol shooting. Reload safely, keep good records, clean your guns regularly, and get out there and compete.

Remember: to improve, you really only have to beat one person -- yourself.

Table 1. Velocity (fps) Required to Make Power Factor

Bullet Weight (gr.)	Power Factor		
	120	125	165
115	1043	1087	1435
120	1000	1042	1375
122	984	1025	1352
125	960	1000	1320
130	923	962	1269
135	889	926	1222
140	857	893	1179
145	828	862	1138
150	800	833	1100
155	774	806	1065
158	759	791	1044
160	750	781	1031
165	727	758	1000
170	706	735	971
175	686	714	943
180	667	694	917
185	649	676	892
200	600	625	825
230	522	543	717

The bad news:

There is no  
'magic bullet'

The good news:

There just might be  
a 'magic handload'  
and you can make  
your own magic!

# Handloading for Hunting Handguns

By DAVE WORKMAN

**EXPERIENCED HANDGUN HUNTERS** have their preferences, and mine is the revolver, preferably one chambered in 41 Magnum for big game.

That certainly does not mean the 41 Magnum is the best hunting handgun cartridge on the map, because it probably is not, nor does it mean that revolvers are the best handguns for hunting, because you will find plenty of argument there. The combination just works for me, and the deer I've shot with it were in no position to argue. A deer or other animal felled by a 357 Magnum, 44 Magnum, or any other popular handgun cartridge including the 41 Magnum, is just as deceased.

My adventures hunting with handguns began as a youth when I would shoot raccoons with a 22 pistol, and I got pretty good at it, too. I vividly remember shooting one 18-pound ringtail high in a fir tree, hitting it three times—on the move along the trunk—late one windy winter afternoon. A couple of other times, I managed to bring down the critters from pre-





Whatever your hunting handgun choice, select the right bullet for the job. This Ruger Blackhawk performs very well with loads using Speer and Nosler bullets in various weights, Alliant 2400 and H-110 powders.

curious perches, once using an old Hy Hunter rimfire six-gun that had no front sight. The experiences hooked me on shooting game with a handgun, and I decided to one day move on to something bigger.

It would naturally be a few years before the budget and the opportunity would make that possible. My home state of Washington was the last of the western states to adopt big game handgun hunting, and it took some lobbying efforts from me and other handgun devotees to make it happen.

Along the way, I'd read the tales by Elmer Keith, Al Goerg and other handgun hunting pioneers, and was fascinated. My budget still being relatively meager, the natural course of things found me buying a reloading press, manuals, and the raw components to start brewing my own loads. That press has seen thousands of rounds, and as you might have guessed, they were not all 41-caliber.

I've had great experience shooting and testing all kinds of hunting handguns. I fell in love with the Taurus Silhouette in 44 Magnum with its 12-inch vent rib barrel and the ability to whack a 10-inch gong repeatedly at 200 yards with open sights. Given ample time, with an opportunity to experiment with various loads, my suspicion is that this revolver would make one heck of a deer shooter, because the 44 Magnum cartridge—loaded to its full potential with the right bullet—is



Big-bore handgun rounds capable of bringing down deer-size game include the 45 Colt (especially when loaded "up" for use in Ruger or Thompson/Center handguns), the 44 Rem. Magnum, 41 Rem. Magnum and 357 Magnum.

loaded with precision ammunition, are capable of phenomenal accuracy, especially when topped by a scope.

I wanted desperately to carry a 41 Magnum Model 657 Smith & Wesson I tested for the 2002 HANDGUNS annual (14th Edition) on a deer hunt, but plans and timing wouldn't cooperate. That gun and my handloads combined to shoot some remarkably tight groups off a sandbag, however.

I've shot a buddy's Remington XP100 in 221 Fireball, and found it to be so dead-on-the-money at ranges out to 150 yards that it was kind of spooky. No prairie dog, rockchuck, rabbit, coyote or other small critter is safe anywhere within

a well-established game stopper.

I shot varmints in Oregon using a borrowed Thompson/Center Encore in 223 Rem., and the pistol simply couldn't miss. A year later, I had another T/C Encore with barrels in both 223 Rem. and 44 Rem. Magnum for a gun test appearing in that year's HANDGUNS annual (10th Edition, 1998), and while seated at a bench, in front of an attorney friend of mine (*what kind of a witness is that, eh?*) I smacked targets at 200 yards consistently. Such guns, when



The 357 Magnum (left) is also a proven small game round, as are the 38 Special (center) and the 32 H&R Magnum.

range of that handgun and the proper loads.

I discovered quite by accident that the 38 Special target load I used for years in a 6-inch Model 19 Smith & Wesson — it's a 158-grain lead semi-wadcutter propelled by 3.5 grains of HP-38 over a CCI 500 standard small pistol primer — is no slouch when it comes to clobbering cottontail rabbits at reasonable distances. I've also worked up a dandy small game load in 38 Special using 4.7 grains of HP38 behind a 125-grain Speer JHP, and I've found that a good load that approaches the +P realm for that cartridge is also a terrific small-game stopper. This load also uses a 125-grain JHP over 10 grains of 2400 ignited by a CCI 550 Magnum primer. The downside of that particular +P load is that there is often quite a bit of powder residue, but the upside is that if you hit a rabbit or coyote in the noggin with that bullet, that animal is not going anywhere.

A couple of years ago, I acquired a Ruger "Vaquerito" single-action six-gun (built on the Single Six frame) chambered in 32 H&R Magnum. You guessed it, not all hunting handguns are big-game stoppers. Some are for small game only, and the 32 H&R Magnum is a sizzling little round that is often underestimated—if not downright ignored—for this purpose.

I spent hours at the press, and more time at the range, working through various suggested loads, finally settling on a 100-grain Speer JHP pushed along by 10.5 grains of H110. Over my Chrony Delta chronograph, out of the 4 5/8-inch barrel, that bullet strokes along at just over 1100 fps. Even with the simple blade front and notch rear sight setup on this particular Ruger, out to 25 yards this particular load in my particular gun shoots well enough that I'm going to carry it along faithfully henceforth for the unfortunate cottontail or snowshoe hare that gets in my way during the hunting season.

Another choice load in that gun, though it shoots slightly lower, is the 85-grain Hornady XTP over 3.7 grains of HP-38, possibly my favorite pistol powder for everything from the 32 H&R up to 45 ACP. It turns in a very credible 900 fps ten feet from the Ruger's muzzle over my chronograph screens.

But the critical component that makes any of these guns — or any other hunting handgun, for that matter — the game-stopper it is designed to be, that it has the potential to



Terrific handgun for hunting is the 44 Magnum revolver. This one from Taurus has a 12-inch barrel and is topped by a Bushnell long-eye-relief scope.

become, is the ammunition you put in it. That, and a steady hand and sharp eye, of course!

### Start With Manuals

There is no secret to creating efficient handloads for a hunting handgun. This is essentially a no-brainer. Consult a loading manual; in fact, consult several. If you can get hold of an older manual or two, study them also, because data may have changed.

For example, my weathered Speer manual No. 10 lists a maximum load for the Speer 200-grain JHP at 18.5 grains of 2400 (then Hercules, now Alliant) but jump ahead a few

years to the Speer Reloading Manual No. 12 and for the same bullet, the maximum load is listed at 16.8 grains of 2400. Meanwhile, the Hornady manual tells me that with the Hornady 210-grain JHP, the 41 Magnum will take a maximum load of 20 grains of 2400.

This is an important point. Do not presume the manuals, while they may provide what seems like conflicting information, are wrong. Whether your gun is a 44 Magnum revolver, or a 35 Remington-chambered T/C Contender, you will want to study those manuals like you were cramming for senior finals, because if you flunk in this game, you might miss meat, you might blow up a gun, or any number of other bad things could happen, often all at the same time.



**Author says time on the range is what proves whether the loads you are working up turn in the kind of performance expected of a hunting handgun, like this single action.**



**Smith & Wesson's Model 657 with full underlug 8 3/8-inch barrel will turn in much better accuracy than indicated by this target, when it is paired with good handloads and ample time is invested on the range to zero it in, with open sights or a scope.**

A loading manual is not just page after page of recommended loads. Every one of mine has sections dealing with the nuts and bolts of setting up a reloading operation, with an emphasis on safety. Simply put, the novice reloader should consult — and trust — the manuals. Don't get creative because you read about some fire-breathing load that some guy wrote about in your favorite gun magazine. Start off well below the maximum load listed for your particular cartridge/bullet combination and work up. Along the way, you may discover a remarkably accurate load that is not the maximum, but does generate the horsepower to flatten a game animal.

One thing I particularly like about the Nosler manual is that it lists the most accurate load tested in each caliber. That's very helpful, not because it will necessarily be *your* most accurate load, but because it provides a strong hint about certain loads using certain components.

You will find literally hundreds of recommended loads for various cartridges using different powders in all of these manuals, typically listing a starting point and a maximum load. If starting with the minimum load and working up, do so in 0.10-grain increments, no matter what propellant you choose. It may take some experimentation, but eventually, you will settle on a propellant that gives consistent performance in your firearm.

I prefer HP-38 in the 38 Special for mid-range target and small game velocities, there are many of my shooting pals who are devoted to the very similar Winchester 231, others who are Bullseye diehards, and others still who insist that Unique is the only propellant on their loading bench. I would not presume to push the reader to one powder or another. Experiment a bit, because each gun seems to have its own preference for a particular load, a certain combination of bullet, propellant, brass and primer.

When it comes to loading magnums, my preferences lean to 2400 and H-110, but here again, others have different opinions. Winchester 296 gets high marks from many magnum shooters, and it really shines in the 44 Magnum, especially beneath a 240-grain bullet. It is not a propellant I'd recommend for use with lead bullets, though.

### **Assemble Good Equipment**

Now, here's where things get pretty subjective. I happen to use loading presses by RCBS, one a single-stage for loading my rifle cartridges and rounds for my 41 Magnum revolvers. Located elsewhere on my compact reloading bench is a Piggyback Progressive mounted on my RCBS Rock Chucker. Are they the best presses available?

For me, perhaps, but any dozen other guys might disagree.

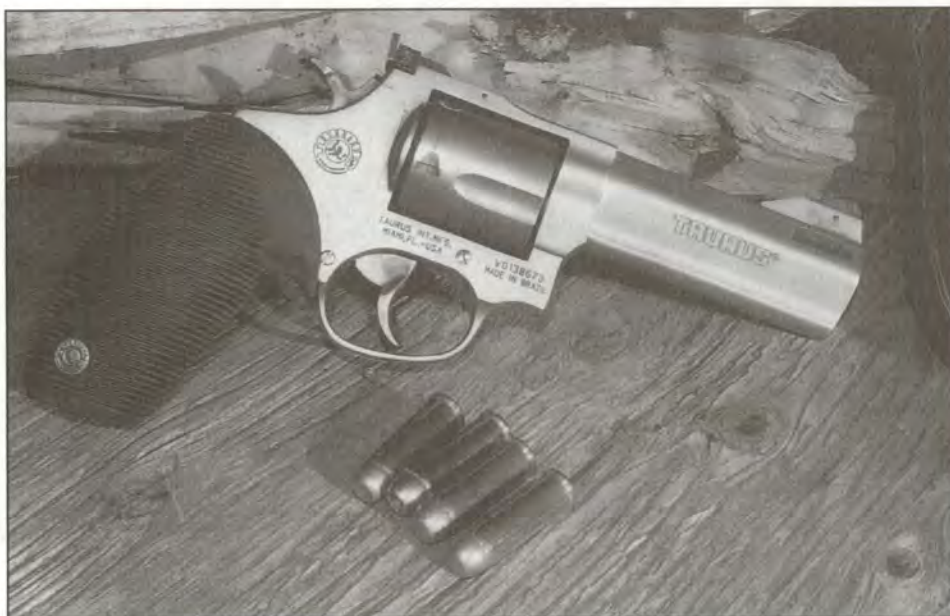

The 130-year old 45 Colt cartridge has reached it's full potential in the past few years, as ample for deer and black bear. Even in a lightweight revolver like this Taurus, the cartridge — properly handloaded — shines.

critical so you can produce consistent ammunition, as I experienced with two different groups fired from my 357 Magnum Colt Python. One group was fired using different brands of factory ammunition, and the other — the tighter one — was produced using handloads that I can attest contained precisely-weighted powder charges, behind 158-grain Hornady XTPs.

You will want a loading block if you reload with a single-stage press, a good priming tool for seating primers, and a case trimmer. There are many other reloading accessories, and a shooter can get as elaborate as he or she wants to. It's all a matter of budget and space.

I shoot and hunt with people who use Lyman, Redding, Hornady, Lee and Dillon equipment of varying age and design, and every one of those units has had its virtues extolled in my presence more than once. Quite honestly, today's reloading presses, no matter who builds them, are probably the best there are, thanks to modern engineering and materials, and generations of experience.

What about dies? Here, again, this discussion is almost entirely subject to opinion. I happen to use Pacific, RCBS and Lyman dies for rifle cartridges, for no other reason than that's what I happened to order or find available at the time I needed them, and they all do the job. For progressive pistol cartridge reloading, I use carbide dies, and all of mine come from RCBS. However, others have found complete satisfaction with carbide dies from the other manufacturers, so who am I to argue? Find a brand you like and stick with it. If you take proper care of your equipment, it should last a lifetime.

You should have a good tumbler for cleaning and polishing brass — mine is a Lyman — and a good caliper for measuring case length, which you will find listed, along with a case diagram, in your loading manual. I first resize my necked cartridges and then toss them in the tumbler for cleaning and polishing, while I tumble my straight-walled handgun cartridge cases, then reload them.

Why the difference? Because resizing a necked case requires case lube, and I don't want that stuff on my brass during the process of re-priming, adding powder and bullet seating, as it's messy, and might just corrupt a primer. When you resize a straight-wall case with a carbide die, all you need is for the brass to be clean.

I much prefer an electronic powder scale, and there are several good ones available. Weighing precise charges is



Author's Ruger Blackhawk will reach out to distances beyond 100 yards, even with open sights, to bring home game.

### Watch for Pressure Signs

One thing about powders, bullets and loading data. Just because a certain combination works for someone, doesn't mean it will work for you, in terms of accuracy or safety.

A few years ago, I cooked up some ammunition using an Elmer Keith-recommended load for my 41 Magnum, and



Whether a double-action like the N-Frame S&W (left) or a single-action like the Ruger Blackhawk (right), hunting-caliber revolvers live up to their full potential with the proper loads.

the results were eye-opening. In both my Ruger Blackhawk and S&W Model 57, I fired these hell-breathers just once, and got consistently flattened primers, cases that were so badly swollen it was hard to eject them from the cylinder, and accuracy went straight to the infernal regions.

Split or swollen cases, cratered or flattened primers, cases that do not eject from the chamber easily; they are all signs of excessive pressure that can pound the heck out of your gun hand, wrist and lower arm, and do serious damage to your gun. If you get loads like this, it is a good investment of time to put them all in the bullet puller, and start over again.

I know some guys who like to “go for the gusto,” and I know that Keith did some experiments with handguns in the early days that would terrify his mother, but just because somebody else does it and gets away with it is no reason to try the same thing. Your results may vary to disastrous proportions. This might be especially true for people reloading such hell-breathers as the 475 Linebaugh, 480 Ruger and 500 Smith & Wesson. All wisdom and logic to the contrary, some people will simply want to “push the envelope” with these behemoth-bore cartridges, and my strong advice is to not be one of them. Stick with the available loading data for these big guns.

For example, if you want 454 Casull ballistics, buy a gun chambered for that cartridge. Don't try loading a 45 Colt cartridge to duplicate the Casull because you're likely to have one very bad day.

Incidentally, the 45 Colt has been around for more than 125 years, and it should not be counted out as a viable game cartridge. It can be loaded more heavily for use strictly in Ruger revolvers and Thompson/Center Contender handguns only. They are far too stout for use in any 1873 Colt Single Action Army revolver or the clones. There are special sections in the Speer and Nosler manuals detailing loads for these handguns. Do NOT use these in your prized cowboy action revolvers. Still, look for signs of excessive pressure

when loading this cartridge up to its full potential.

Which brings us around to this reminder: Don't just think that pressure signs show up with big magnum loads. Some years ago, I tried what was supposed to have been a moderate load for my 357 Magnum, using a moderate charge of HP-38 under a 158-grain semi-wadcutter, and I repeatedly experienced cases split near the mouth. The primers were not flattened, and I don't recall any noticeably heavy



Some years back, Workman felled this 2-point mule deer buck on the move with two shots from his Ruger. His handloads, featuring Speer 200-grain bullets propelled by 17.5 grains of 2400, stopped this buck in its tracks.

recoil, but split cases are to me about the same as a brick upside the head, so I stopped using those loads.

Handgun cartridge reloaders need to carefully examine every case before it goes in the press. Look for tiny cracks around the case mouth. Give an extra look at any fired case with a flattened primer. I routinely discard cases that go in the press real hard despite adequate case lube.

And here's a note: For reloading straight-wall cases, I really prefer a carbide sizing die as noted earlier. These make

Single-shot handguns like the Thompson/Center Encore (top) with a scope and the T/C Contender make terrific hunting handguns. Barrels chambered for a wide selection of hunting cartridges are available



Not all hunting handguns are for big game. The 38 Special and 32 H&R Magnum are very effective on small game, and they are made more so with good handloads. On top, author uses a 158-grain lead semi-wadcutter in his small-game loads, and on the bottom, an 85-grain Hornady XTP.

reloading so much smoother, and work best of all with nickled brass cases. Even if you are producing ammunition from new, unfired brass cases, always run them through the sizing die. I have had new cases turn out to be too large to accept a bullet or fit properly in a chamber.

Check magnum cases for length every time they're reloaded, trimming to length when necessary, and that goes for my 32 H&R Magnum cases. After that, debur the case mouth inside and out because trimming leaves a pretty sharp edge and will, if left unattended, interfere with bullet seating.

When belling the case mouth, it is not necessary to widen it too much. Brass is a soft metal, but it cannot be stretched too far. Belling the case mouth too much can shorten case life, even on a straight-walled case and most assuredly on higher-pressure magnum cases. All that stretching and constricting is stressful to the metal, even if you can't see it with



Don't think a single-action revolver with fixed sights is accurate enough? Here's a 15-yard target author fired using handloads charged with H-110 and 100-grain Speer JHPs.



Colt Python in 357 Magnum, shown here with author's handloads topped by 158-grain Hornady XTPs, a bullet easily capable of bringing down deer-sized game.

the naked eye. Excessive bellling may even make it difficult for the case to fit into the seating die.

If you're shooting a handgun chambered for a necked case, carefully examine the case shoulder as well as the neck. It may be rare, but you can occasionally find small cracks on the case shoulder. Such cases should be tossed.

Most, but not all, shooters of my acquaintance simply neck-size their necked cases, unless they are to be used in more than one gun of the same caliber. Some will discard cases after five or six reloadings, even if there is no visual problem. Others have had good luck loading cases up to twice that number of times with no apparent ill effect.

### Bullet selection important

Hunting big game with a handgun is a very serious proposition, and the link between hunter and game is the projectile. Much attention must be given to the type of projectile so that it is matched to the game animal one is hunting.

For deer-sized game, a jacketed hollow-point or expanding soft-point bullet will get the job done with a revolver cartridge, but if the target is something larger, say elk, caribou, moose or large black bear, you're going to want a bullet that penetrates deeper, so you may want to ignore the hollowpoints and go right for the heavier jacketed soft-points. This general rule applies whether you're shooting a straight-wall pistol cartridge or a necked rifle cartridge in a properly chambered handgun.

Heavier bullets retain more energy downrange, and that's important because it is not always possible even for a rifleman to stalk close to a game animal. Big-game hunting handguns are not necessarily short-range weapons, but by the same

token, it's advisable to get as close to the target as possible to ensure the best bullet performance. Translation: don't push your luck and risk leaving a wounded animal in the woods, or missing completely in an effort to prove how good a long-range handgun shot you are, even if your hunting handgun is equipped with a good scope. It is good to have confidence in your hunting handgun, and the loads you feed it. But don't substitute confidence for common sense about the capability of your handgun and the ammunition you produce. It is challenging to test the limits of any firearm, and the limits of your marksmanship, but not at the expense of a game animal that deserves to be considered far more than a lab experiment.

It just might pay off to establish your "maximum effective range" with your hunting handgun and ammunition. Figure that an animal's heart may be no larger than a small grapefruit, and use that size as your limiting factor. Find the maximum distance at which you can consistently hit a target that size, and then limit yourself to shooting within that range, whether it's 50 yards or 150 yards.

You may also want to test the penetration capability of your bullet at these ranges. Soak a thick stack of newspapers, tie them in a bundle and set them out at various ranges and fire test shots. This will give a shooter a pretty decent idea about how deep a bullet will penetrate, and how well it will expand.

You will be a better hunter for it, and a more efficient handgunner as well. In the process, you'll spend many an enjoyable hour at the loading bench and the range.



Prairie dogs, rockchucks, rabbits and similar-sized targets don't stand much chance against a well-tuned hunting handgun.

If you have access to a PC, and are not using it to aid in your reloading, you are missing a lot.

# Computers Can Help the Reloader

By BOB KRAWCZYK

**MANY OF US RELOADERS** use computers to enhance our sport and hobby. And the ways you can use them are many and varied. Let's look at a few examples of how they can be useful to obtain latest loading data, or for external ballistics for rifles, pistols and shotguns, or for record keeping and some other uses, as well.

Let's take an example, and explain how the computer helped to fix a problem. In 2003, Winchester added a new 28-gauge shotgun load for higher performance. I tried a case of them for Sporting Clays with good results. But the problem was that Winchester retained the old, reliable 28-gauge AA shell and target loads, and offered this new additional 28-gauge AA-HS shell for Sporting Clays at higher velocity. This new AA-HS shell, however, utilizes a totally new hull (or case), which requires *different* Winchester wads and loading data to reload. In fact, it is *NOT* identical to the older AA, and requires all new loading data for all reloading. Yeah, the hulls could be told apart, all right, but availability of the special new Winchester wads at your local supplier was a major problem





A personal computer is boon for helping make good effective reloads for hunting and target shooting.

for a few months. And, since powder manufacturers only update manuals annually (*if that*), without a computer you were totally out of luck for loading data for these hulls.

But with the computer, it was an easy task to get on line, check out the powder manufacturers' websites, and *presto!* – the answer was right at hand, and included a variety of alternative manufacturers' components, such as wads and primers, as well. The first site I tried (Hodgdon) listed the new hull, and had over 100 good, safe loadings listed, along with pressure data and velocities of the loadings for these

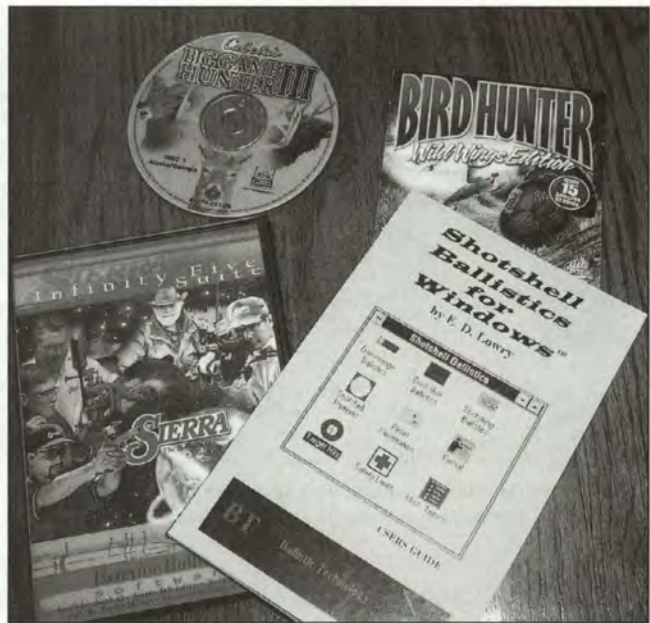

At the top are some shooting "games" programs for entertainment, while the bottom two are for external ballistics for our reloads.

alternative components. I was back in business, able to reload these new hulls with good results

How many times have we had to deal with "New, Improved" cartridges, powders, primers, wads, bullets and hulls, and couldn't get the old component, but didn't have data for the new stuff? Wait for a manual to be published, and you just may have a long wait. But with the Internet you have easy access to the latest data and, another big advantage, you can just print the data that you require, not have a big stack of manuals to paw through. Quick, efficient, and handy.

I know that a lot of people were upset by the absence of data for the 500 S&W Magnum, when it first came out, but

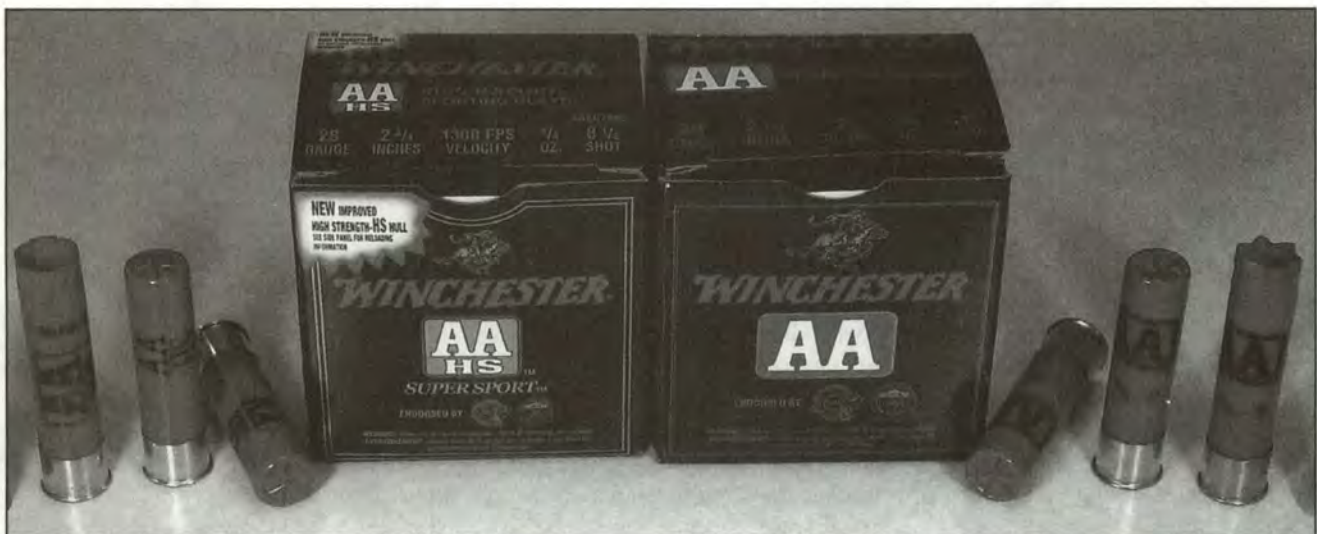

Winchester's new 28-gauge AA-HS shell, and the proper Winchester wad are shown on the left. However, it requires all new reloading data, and when introduced, the proper wad was not available at some dealers. How to fix this?



Trying to obtain data for loading the AA-HS shell, I selected a powder manufacturer's website (Hodgdon Powder), and the Home Page comes up.

Hodgdon has a neat section on loading for it, listing both Starting Loads, and Maximum Loads. The same situation occurred when Remington announced their Ultra-Magnum line, and when Winchester came out with their Super Short Magnums. Now, with a computer, we don't have to wait for what seems like forever to get the data in our hands, particularly if we have a new gun and some empties to reload.

The websites for so me of the powder manufacturer's are:

Accurate Powder - [www accuratepowder.com](http://www accuratepowder.com)

Alliant Powder - [www.alliant.com](http://www.alliant.com)

Hodgdon Powder - [www.hodgdon.com](http://www.hodgdon.com)

IMR - now a part of and included in Hodgdon

Vihtavuori Powder - [www.vihtavuori-lapua.com](http://www.vihtavuori-lapua.com)

But that's just the start of what computers can do for us. Exterior ballistics is what happens when the bullet leaves the muzzle. I am often asked, "Are there any commercial computer programs on exterior ballistics?" The simple answer is yes, for rifles and pistols, but few for shotguns. I'll discuss rifles and pistols first.

For the rifle and pistol shooters, exterior ballistics programs give us the "goodies" we all like to know, such as drop tables, remaining energies, trajectory (including graphics), and how does MY gun and load perform with a given load. Although "muzzle velocities" of loads are listed, in most cases, guns vary in how well they meet them—based upon barrel length, bore tightness, chamber dimensions, and a whole raft of other items. And knowing this, we have a whole series of questions in the back of our mind when we work up a good, accurate load. Well, with the growing availability of low-cost chronographs, they are now readily available to the average shooter. You may have one, or know someone who does, or maybe your gun club or range has one. It's usually a simple matter to get your firearm, be it rifle or pistol, chronographed with your favorite load. With that accomplished, you can get a wealth of information from a ballistics program.

These are relatively inexpensive programs, for what they

give us. I have been using the Sierra Infinity5 Exterior Ballistics program, put out by Sierra Bullets, as I previously had been using an earlier version of this program, with very good results. There are others out there, and Barnes and others also produce good ones. At first glance, after loading the program, the screen seems "overwhelming", but within an hour of starting to use the program, you will be going like an expert. But what can these programs do for us?

The simple answer is a lot. For example, the programs have everything in them that the latest reloading manual has, including

SHOT	POWDER	PRIMER	WAD	POWDER WT. (GR)	PRESSURE	VEL. (FPS)
3/4 oz.	Universal	CCI 209M	BP 50 28	14.3	11,000 PSI	1200
3/4 oz.	Universal	CCI 209M	BP 50 28	14.6	11,800 PSI	1225
3/4 oz.	Universal	CCI 209M	Fed. 2891	14.2	12,400 PSI	1200
3/4 oz.	Universal	CCI 209M	Rem. PT28	14.1	10,200 PSI	1200
3/4 oz.	Universal	CCI 209M	Rem. PT28	14.7	11,300 PSI	1225
3/4 oz.	Universal	CCI 209M	WAA28HS	14.3	12,000 PSI	1200
3/4 oz.	Universal	REM. 209F	BP 50 28	14.2	10,400 PSI	1200
3/4 oz.	Universal	REM. 209F	BP 50 28	14.7	11,100 PSI	1225

Selecting their data for the 28-gauge AA-HS shell, these loads came up. There are over 100 loads listed, along with alternative and common wads, for this new AA-HS shell.

data, and more. Let's assume that you know which bullet you want—and not just Sierra's, but just about any other you can name. It has a built-in file for each major bullet manufacturer, including Sierra, Barnes, Berger, Black Hills, Combined Technology, Federal Cartridge, Hornady, IMI, Lapua, Lazzaroni Arms, Norma, Nosler, PMC, Remington, RWS-Dynamit Nobel, Speer, Swift, Winchester and Weatherby. A very thorough compilation. All of the offerings, plus the ballistics coefficient for each, are included so that it can accurately portray the trajectories, energies, remaining velocity, wind-drift, and any other item you can think of. In addition, it has a file for custom bullets, in case you "build your own", and that is where I put in data for muzzle-loading projectiles, and rifled slugs, sabots, etc. for evaluation and information.

Once the bullet is selected, then it can be "loaded". The suitable section of the *Sierra Reloading Manual* comes up on screen so you can select the load you wish to use, and the appropriate velocity obtained. You then can run off the graph, drop tables, trajectory table out to the distance select-

ed, and a whole host of other options. This is the option most guys use.

As I said, though, if you have access to a chronograph, you can "tailor" the information for your specific rifle, based upon the chronograph results. Then you can further change the ambient and other conditions to accommodate your actual conditions. For example, if you live in Wyoming and shoot at 5000 feet above sea level, the exterior ballistics won't be the same as for a person shooting in New Jersey at sea level. These conditions are easily set.

In addition, there are numerous "pulldown" manuals where you have the options of editing data, printing or saving graphs of trajectory, etc. While many options are included in each, the headings for these are as follow:

File - contains all saving, printing, editing operations;

Load Bullet - allows selection of bullet manufacturers, custom bullets, and bullet selection;

View - allows setting trajectory parameters, and environmental conditions;

Trajectory - allows numerous trajectory parameter adjustment, and comparisons of loadings;

Operations - Allows "point-blank range" calculations, up-hill/down hill effects, max. range, etc.;

Trajectory variations - to allow variations to be shown;

Reloading data - rifle, pistol, single-shot;

Reference - History, service phone numbers, reloading information, videos, exterior ballistics;

Help - to assist the user, includes Infinity Help, a user's manual, and miscellaneous aids.

This is a well-organized, easy-to-use and navigate program. Even a dummy like me can operate it, though it looks a little complicated when you first load it. Best of all, though, it is very useful. For example, I like my big-game rifles sighted so that the bullet strikes no higher or lower than 3 inches at the useful range, but only + or - 1 inch for my varmint calibers. I can "change zero" at the computer several times, so that I

am sure I get the flatness of trajectory I require for either varmints, deer, or multi-range targets. I don't have to sight in for a "fixed" 100- or 200-yard range (*which is probably not taking advantage of the rifle and load*), since I load for maximum performance. And I can compare bullet performance prior to loading and buying the bullets to make sure I get the performance I want the first time. The program is perfect for that.

And this is just one of the features. You can change "sight height" to match your rifle exactly, which has a dramatic effect on "apparent trajectory". That means that a rifle "appears" to shoot flatter if you have the sights higher above the centerline of the barrel. This is caused by the bullet having to climb higher to get to the line of sight, so you have the muzzle canted slightly upwards more to do this. That's why a scoped rifle "seems" to shoot flatter than it does with lower iron sights. In other words, you will know what to expect from your rifle before you start.

Once I started using these programs, I often wondered how I ever reloaded without them. In addition, I have picked up a lot more knowledge about my rifles, and I rely on and have more confidence in my reloads than I do in factory loads.

As far as shotgun ballistics goes, I am only aware of "Shotshell Ballistics for Windows", by E. D. Lowry. Mr. Lowry was the prime ballistician for Winchester for years, and he retired a few years ago. While this program is not as extensive as the rifle programs, it has some excellent information on shotshell ballistics readily available at your fingertips. It is available at most of the bigger suppliers of reloading equipment and components. I obtained my copy from Precision Reloading.

While the menu selection appears somewhat limited, in comparison to the rifle programs, there are sections on Downrange Ballistics, Buckshot Ballistics, Shotstring Ballistics, Shotshell Patterns, Pellet Penetration, Recoil, Target

Hits, Safety Links, and Miscellaneous Topics. Input for any of the topics is simple, and by following a series of screens which lead you to input shot type (lead, steel, tungsten, bismuth, etc.), shot size, shot charge (oz.), velocity, choke, shell length and gauge, a screen comes up with the answers. In addition, at this point, at the bottom, there is a series of additional pop-up menus which allow you to look at other parameters, such as maximum range, maximum height, properties, performance, and drift & drop. This program offers a wealth of information of factual data.

One feature of this program, the Shotstring Ballistics, gives a good graphic explanation of how the path of the target—and the target itself—gets

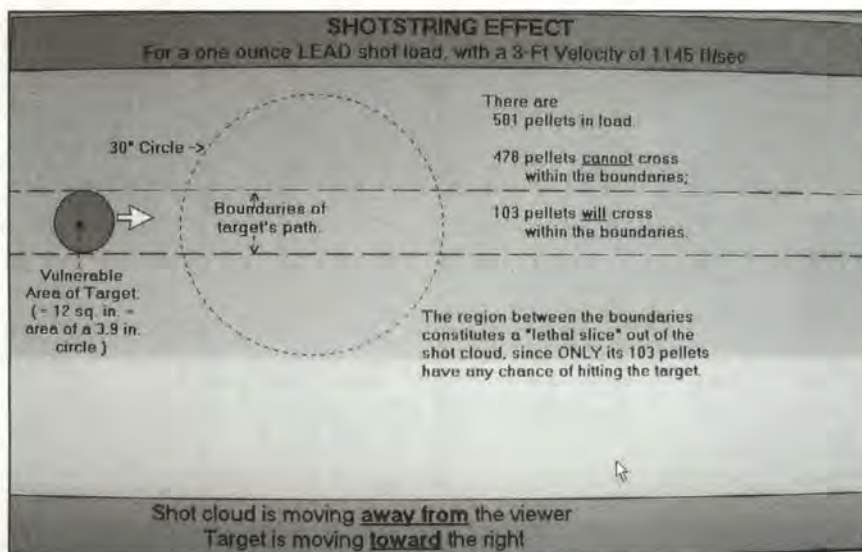

The Shotstring Effect shows how many pellets actually cross the target area from a vertical viewpoint.

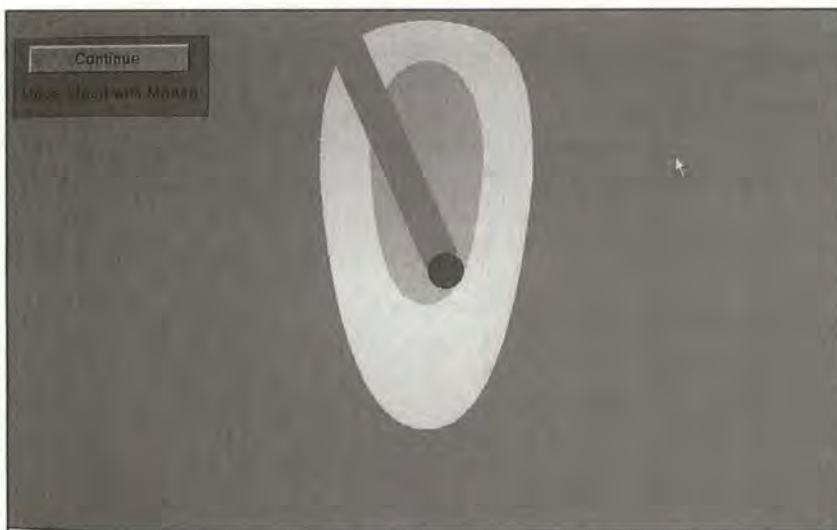

**This horizontal look shows how the shot cloud affects the target when the target is perfectly centered. You can change conditions to show if you are a little ahead of—or behind—the target, as well.**

struck by the strung-out shotstring. You can also move the target in relation to the shot cloud so it can show what happens if the target is not hit by the center of the load. Interesting stuff! The Target Hits section is useful for us when patterning, as it looks at a certain “theoretical” pattern, and redoes it several times so that you can determine what variability in performance you can expect if you don’t center the target.

The Miscellaneous Topics section includes reference articles and drawings to cover many key aspects of shotshells that we usually don’t think of, but are important from a performance viewpoint. The more I use this program, the more information I find, and learn a lot in the process.

What else can a computer do for us? Actually, about all our imaginations will allow. For example, I occasionally use “Granddad’s Shotgun” for a round or two of Skeet. This old hammer double, with both barrels Cylinder-bored, was made sometime in the 1890s, and proofed for blackpowder. I had it verified to be safe for blackpowder loads by a gunsmith, but it has 2 9/16-inch chambers, so I have to trim 2 3/4-inch shells down. I first verified the gunsmith’s inspection by making up some heavier “proof” loads, lashing the gun to a tire, and pulling the triggers with a cord from behind a tree. It “passed” with flying colors. I can use blackpowder, or its substitutes (like “Cleanshot” or “Pyrodex”) to reload. But I don’t use plastic wads, as they melt in the barrel, so I had to find old-style felt or paper wads. Paper shells are ideal, but plastic can be used. However, plastic shells just last for a couple of firings before they start to develop pinholes and have to be discarded. I also use light loads – 2-3/4 drams – and 1 ounce of shot in the 12-bore. But the clay targets break nicely, thank you, and it sure is a conversation starter. Everyone wants to try shooting the old gun.

Be aware of one *SAFETY* consideration - if you have a good, safe gun and want to try this, you can use a standard reloading press for most operations, but *NEVER* use blackpowder or its substitutes in a powder-metering device! That must be done manually, with a blackpowder measure.

How did I learn to accomplish loading blackpowder shells? Well, I did a web search on blackpowder shotshell reloading, and found several interesting and factual articles on “how to”, and a source for the wads, as well. I could even get brass shotgun shells, if I desired. In fact, I now use a garden hose and water to wash out the barrels. It takes me less time to clean this gun than it does to clean one of my modern guns. All of this due to using the Internet.

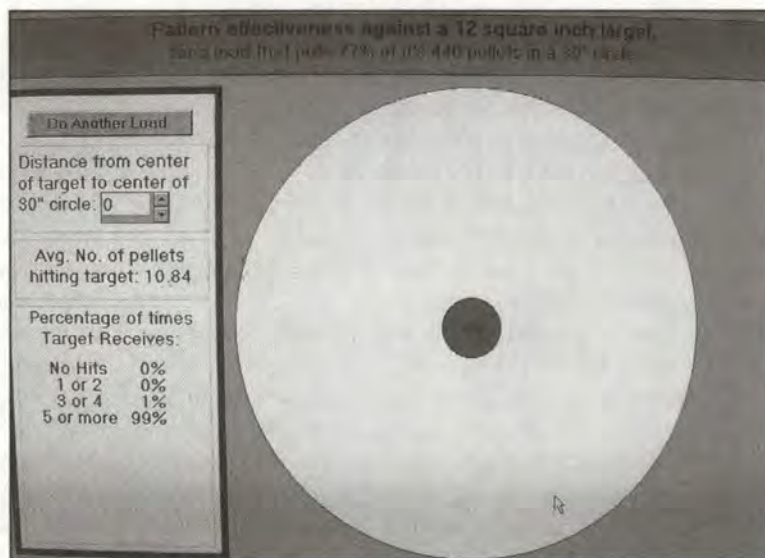

**What is the probability of hitting the target? Here we look at a perfectly centered target. This target will break.**

Now, I realize that topic was “pushing the edge” a little bit, but I just want to show the scope of subjects available, and the fun involved, if you just do a little searching.

But let’s just suppose that you have heard of a certain brand of foreign shotgun shell or rifle cartridge that is reasonable in cost, and performs very well. You want to try it. Well, just do a web search on the brand name, and you will usually turn up a U.S. distributor, along with a number of suppliers and retailers, price comparisons, etc.

Looking for alternative wads or bullets? Again, do a web search, and you will be surprised at what is available. And, you can usually also find a local source.

By the way, Remington is introducing their new shotgun wads—same basic design—but now they are “stitched” wads. What’s a stitched wad? Well, that’s easy; the petals in the shot cup are lightly attached together at the front for ease

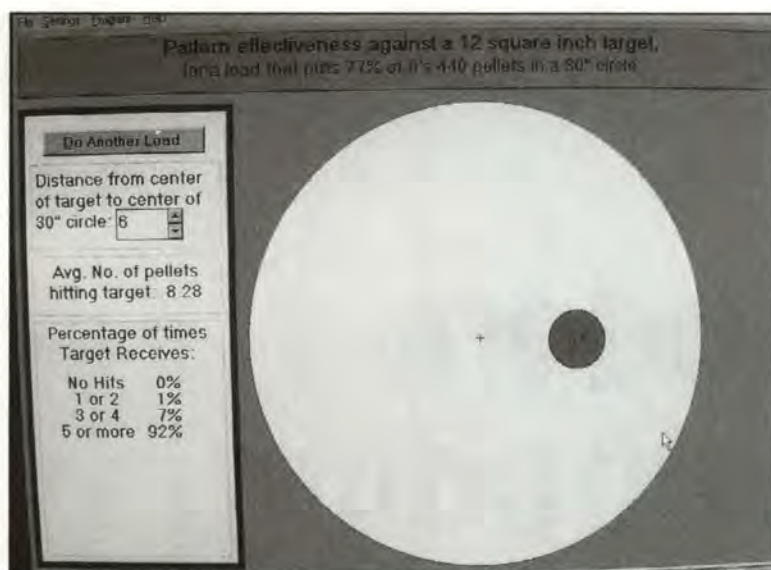

**But what happens if I fall slightly behind the target? Still not bad—this target should break.**

took a little initiative on my part, but it's not rocket science.

Another spreadsheet project that I maintain is a "Pet Loads" project. When I find a very good load, I just add it to my list of favorites. I simply write the reloading data in the appropriate columns, the specific use, and its capabilities – for example, "groups average .xx inch", "explosive on woodchucks", or "good sporting clays close-range load". It's handy to have, and keeps me from searching through manuals for a load I haven't used in a while.

But there is another use for them - and it is fun, exciting and challenging. A computer is a good "game machine" as well! Let the kids have their specialty "game systems", but if you have a couple of hours to kill, playing a shooting game on the computer is fun, too. There are lots of them on the market these days, and they do

of packaging, and convenience in handling by the reloader. They use the same reloading data as before the "stitching". On firing, the "stitching" breaks, and it gives the same performance as its predecessor. How did I find that out? On the Internet.

Looking for a new gun or reloader? The latest in shotshell or rifle cartridge offerings? Again, get on the Internet, and do a web search. You will get all the information you need, and without a bunch of catalogs to go through, then throw out. And active companies update their sites frequently, much more often than they update catalogs.

Going on vacation? Why not take the shotgun along and get some practice. Check out [www.shotgunsports.com](http://www.shotgunsports.com) and see what's available. This website has a compilation of shotgun ranges for Skeet, trap and sporting clays, and shooting preserves all over the country. I use this site to see which gun I should take along on vacation so I can get some variety, and meet a bunch of nice folks while I am at it.

Planning a big game hunt? All the information is available on the 'net. Just do a web search on the species and area, and you can get a wealth of information.

Here's another project that I have ongoing. I am doing a statistical study on my reloading capability. Whether rifle, pistol or shotgun, I am weighing the powder charges, wads, and the shot charge or bullets. Not for every round, but a couple of times per box. Then, I load the data using a spreadsheet program to chart the data, and press the "statistics" command. Yeah, it takes me a little time, but I have been able to get my reloading variability cut way down, and the performance of the completed cartridges is a lot more uniform. It's to the point where I can cut back on the sampling now, but still take advantage of the improvement. I think it was a worthwhile project, from both a safety and a performance viewpoint. It wasn't hard to do, and it

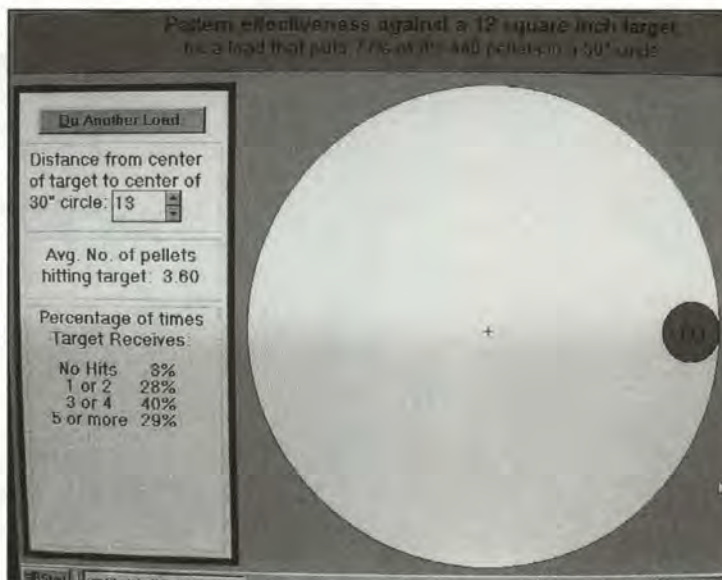

**Falling 90 percent behind with the pattern, I still stand a fair chance of a target break—but I don't dare fall any further behind!**

require a little skill to use. And there are target games, big-game hunts, bird hunts, duck hunts and others out there. You might think this is just for kids, but once you try one, you will find out that they are fun and addictive. In fact, the better ones even require the appropriate lead on moving targets. The visuals are also good, and you will probably wonder why you didn't try them before.

Now, these are some of the uses I have found to date. I am sure that even more uses will come out in the future. These are the things that anyone with a computer can do to enhance reloading, get better results, shoot more often, and make all of us more effective shooters. The guys at the local gun club will even start considering you a "guru". Give computers a try—you won't be disappointed.

Reloading  
smokeless  
powder cartridges  
for cowboy action.

# Modern Reloading, Old Fashioned Sport

By JOHN TAFFIN

**COWBOY ACTION SHOOTING** remains the fastest growing organized shooting sport. Thus far it shows no signs of slowing down and certainly has not yet peaked, as all shooting sports eventually seem to do. SASS (Single Action Shooting Society) is the largest CAS organization and has now reached the 75,000 mark in membership. There are several other smaller groups, and certainly thousands of shooters who enjoy cowboy action shooting without belonging to any national organization. I would guess there are between 150,000 and 200,000 active participants in the sport of cowboy shooting.

There are several companies, such as Black Hills Ammunition, MagTech, Ten-X, and Ultramax, providing factory ammunition especially designed for cowboy action shooters. For those who choose to craft their own ammunition, companies such as Oregon Trail Bullet Co. offer a full line of properly designed CAS bullets, while powder companies such as Accurate Arms, Alliant, Hodgdon and Winchester offers suitable powders for the loads

required by CAS participants. There are certainly other bullet companies and powder companies offering the proper components, however, the combinations become nearly endless and I have chosen to do most of my reloading with the above-mentioned products. This does not necessarily make them better than others; they are simply the easiest for me to access—especially when it comes to bullets, as the Oregon Trail Bullet Co. is only a two-hour drive from where I live in southwest Idaho.

Cowboy action shooting is a broad activity that provides many reasons for participating. For some it is the clothing. I am so thankful CAS has spawned a whole new industry providing period-style clothing, thus giving us access to authentic dress of the 19th century. My everyday style, whatever I happen to be doing, is always same: Wrangler jeans, Wahmaker vest, Olathe boots, a long-sleeved shirt and, when outside, a custom hat. I always dress “cowboy”, so clothing is not number one for me.

For others, camaraderie is extremely important. Cowboy action shooting events, especially on the local level, are one of the best ways to form lasting friendships. I have been involved in shooting and hunting for so long and made so many genuine friendships over the past four decades, camaraderie is not my number one CAS driving force.

Competition has always been an important part of Cowboy action shooting and definitely a large part of my life as I have always looked for activities in which I could excel. When cowboy action shooting started I was a fierce competitor and could often win local matches. I could easily beat all those shooters I got started in the sport; however, things have changed. Those new shooters have become better and better, while I have gotten older and slower. Also, in the past decade competition has changed dramatically and I am not willing to do what is necessary to continue to compete successfully, and win.

If it is not clothing, camaraderie, or competition keeping me active as a cowboy shooter, what is it? My number one reason today—that I suspect has been my top reason all along, as well as the driving force for thousands of other shooters—is being able to use the greatest firearms ever devised by man: those six-guns and lever-guns from the last third of the 19th century. For me there is a definite spiritual connection to the past every time I shoot these classic designs. Cocking the hammer on a single-action six-gun, or working the lever on a Marlin or Winchester, is a great cure for many of the things that ail us. It certainly beats “take two aspirins and go to bed”!

When it comes to reloading smokeless powder cartridges for CAS, there are two definite and distinct classes of shooters. The smaller class is made up of those who are still fiercely competitive and have discovered that to really remain at the top they

must shoot loads exhibiting little or no recoil. They have found the answer to be light bullets with less-than-minimum powder charges in 38 Special cases. They shoot very fast and are easy to spot as their six-guns and lever-guns never rise in recoil, their loads are relatively quiet, and their bullets barely make it to the target... registering a “pling” when they hit.

The much larger class of shooters are those shooting much more authentic loads. They enjoy feeling and hear-



RCBS's Pro 2000 allows for easy and rapid loading of large quantities of cowboy action shooting loads.



RCBS offers special Cowboy Three Die Sets especially for loading the lead alloy bullets used in cowboy action shooting.

ing their six-gun buck and roar as the hammer drops and hearing the following "Clang!" as the bullet hits the metal target. They are more concerned with competing with like-minded friends than trying to come in first. These are the men and women more likely to be found shooting six-guns and lever-guns chambered in 45 Colt, 44-40, 38-40—the three main six-gun/lever-gun cartridge combinations of the Frontier Period—as well as the now-resurrected 44 Russian, 44 Colt, and 45 S&W. If recoil presents physical problems to these shooters, they turn to the lightweights of the 19th century, the 38 Long Colt or 32-20.

Although many shooters choose to use original six-guns from the 19th century, or replicas thereof, there is also a very large group using Ruger single actions, both Blackhawks

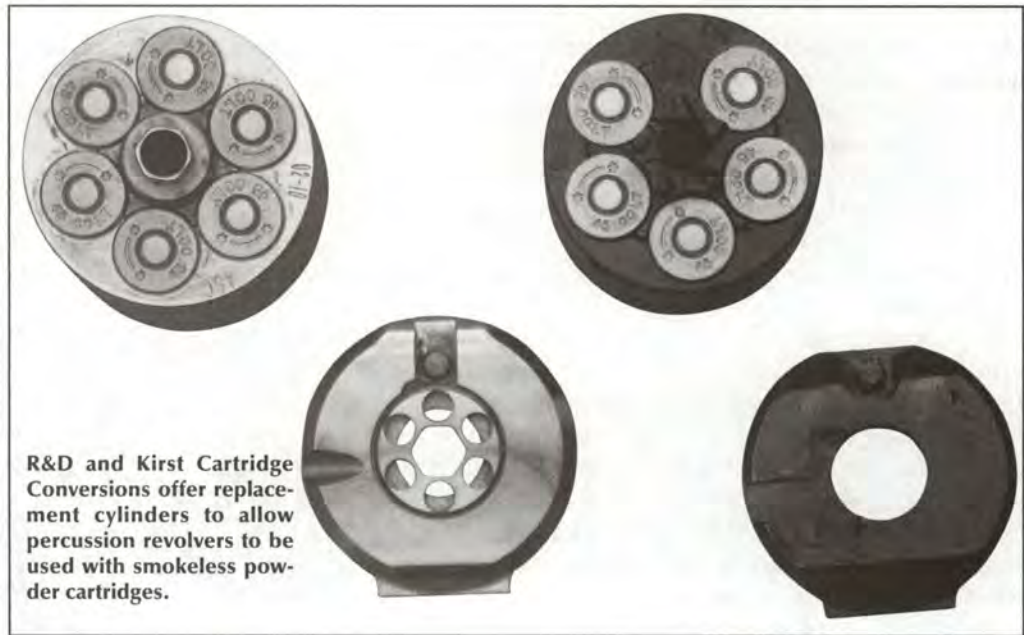

R&D and Kirst Cartridge Conversions offer replacement cylinders to allow percussion revolvers to be used with smokeless powder cartridges.

and Vaqueros chambered in 357 Magnum, 44 Magnum (*properly loaded*), and 45 Colt. No matter what six-gun or lever-gun is used, and no matter what bullet weight or caliber is chosen, the simple SASS rule states six-gun loads must be under 1000 fps muzzle velocity while the limit for lever-guns is under 1400 fps. Any six-gun load under 1000 fps can be expected to stay under 1400 fps when fired in a lever-gun. Unfortunately there is no lower level for six-guns (*I think it should be 650 fps with a standard-weight bullet*), thus allowing some shooters to participate with loads in the 300-400 fps range. Somehow, it seems to me this latter group has missed something very important about cowboy action shooting.

Thanks to Black Hills Ammunition working hand in hand with Starline Brass, we now have exceptional quality brass in virtually every caliber/cartridge originally offered in the historical period covered by cowboy action shooting. This includes 45 Colt, 45 S&W, 44-40, 44 Russian, 44 Colt, 38-40, 38 Long Colt, and 32-20; as well as those Johnny-come-lately offerings out of the 20th-century, the 38 Special (1899), the 44 Special (1908), the 357 Magnum (1935), and the 44 Magnum (1956). That gives us a full dozen chamberings to choose from. There must be some shooters out there using properly loaded 41 Magnum Rugers and Marlins also.

In addition to all of these cartridges, six-guns can be selected from a long list that includes Ruger and Colt single actions; replicas of the Colts; cartridge conversions, the 1872 Open-Top, the Model P, the Bisley Model, and even the Flat-Top Target version of the Bisley and Single Action models; Smith and Wesson's Schofield and #3 Russian; and Remington 1875 and 1890 single-action models. And it doesn't stop there! Thanks to R&D, Taylor's and Co, and Kirst conversion cylinders, we now have cartridge conversion cylinders chambered in 45 Colt and 38 Special to replace the cap-and-ball cylinders found in the 1858 Remington and Ruger Old Army.



Spray-on lubes allow bottleneck cartridges, such as the 38-40 and 44-40, to be resized almost as easily as straight-wall cartridges are using carbide dies.





A 3rd Generation Colt Single Action Army 45 with Alliant powders, Unique, Red Dot, American Select, Bullseye; all well-suited to CAS loads.

When it comes to lever actions we have several Marlin 1894 cowboy models chambered in 38 Special, 357 Magnum, 44-40, 45 Colt, and 44 Magnum; Winchester's current Model 1894 offered in 45 Colt, 357 Magnum, and 44 Magnum; and replicas of the 1860 Henry, the 1866 Yellow Boy, the 1873 and 1892 Winchesters all chambered in six-gun cartridges as required by cowboy action shooting rules. The 1860 Henry and 1866 Yellow Boy were originally chambered in 44 Rimfire; however, they are now offered in 44-40 for modern cowboys, while the 45 Colt, 44-40, 38-40,

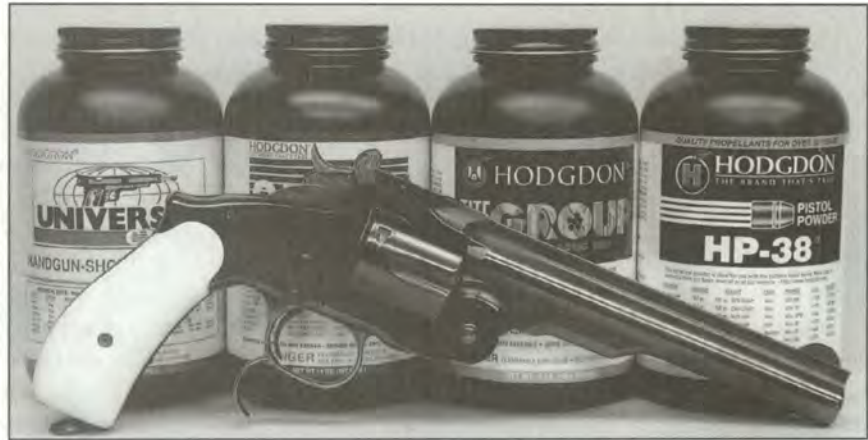

Hodgdon offers Universal, Clays, TiteGroup, and HP38 for loading for cowboy action shooting. Six-gun is Navy Arms' replica of the S&W Model #3 Russian.



Winchester's 231 is an excellent powder for use in CAS cartridges such as the 45 S&W used in this Smith & Wesson Model 2000 Schofield.

44 Special, 44 Magnum, 38 Special, 357 Magnum, and 32-20 can be found in one or all of the 1866, 1873, and 1892 Winchester replicas. Even though these are all made of modern steels they should be loaded cautiously. The 1860, 1866, and 1873 are still made with the original style toggle-link action and are not strong enough for anything other than standard loads. All loads listed herein are considered by the author as being safe in replicas of all single-action six-guns and lever-guns.

Most of my loads for cowboy action shooting are assembled with RCBS's Pro 2000 progressive press, which has several features I find most desirable. First and foremost is the primer feeding system. Instead of a vertical tube

holding 100 primers stacked on top of each other, the Pro 2000 utilizes plastic strips, each holding 25 primers, which are fed horizontally. The strips can be purchased already loaded and can then be reloaded using the special tool provided by RCBS. After spending several hours reloading the plastic strips I can then spend days loading ammunition without ever having to stop and fill primer tubes.

The second feature I really like is the fact the powder measure is not part of the die plate, but rather stays with the press as dies are changed. To me this is very convenient as several cartridge/bullet combinations can be loaded with the same powder charge. The easily changed (*takes about 10 seconds*) die plate has

four holes, allowing use of a standard three-die set, or separate dies for seating and crimping. RCBS offers special cowboy die sets with 19<sup>th</sup> century brass coloring, designed especially for the use of RNFP (round-nose flat-point) lead alloy bullets that most cowboy shooters prefer. Wide, flat-nosed bullets are safe when loaded in the magazine tubes of lever-action rifles. Round-nose or pointed bullets of any kind must never be used in lever-guns as recoil—or something as simple as the butt of the rifle hitting the ground—can cause the bullet nose to hit the primer of the cartridge case in front of it, causing it to detonate. Stay with flat-point bullets for safety.

Finally, the primer seating punch is easily changed from Small primer to Large primer by loosening and tightening one nut. An added bonus, for me at least, is the fact the same shell plate handles my three most-used CAS cartridges: 45 Colt, 44-40, and 38-40. Since I often use the same powder charge for all three, and keep die plates loaded with RCBS cowboy dies for each cartridge, it takes me all of 10 seconds to change from one cartridge to the other. The same shell plate also handles the 45 S&W.

The 45 Colt, as well as the 45 S&W, 44 Colt, 44 Russian, 38 Long Colt, 44 Special, 44 Magnum, 38 Special, and 357 Magnum are all straight-walled cartridges for which carbide sizing dies are available. The 44-40, 38-40, and 32-20, all being tapered or bottlenecked cartridges, must be lubed before sizing. This is no reason to prevent them from being loaded on a progressive press. I simply place about 100 cleaned cases in a shallow cardboard tray, lightly apply a spray-on lube, shake and spray again, and they are ready for loading on the progressive. Most of these lubes dry well enough on their own that with the pressures involved in CAS loads I do not find it necessary to wipe the cases down before shooting.

Some cautions should be noted here. There are shooters using fillers such as Dacron or Cream of Wheat when shooting smokeless powder loads. I consider this a very dangerous practice having seen more than one firearm taken apart by shooting smokeless powder and fillers combined in the cartridge case. Others use very light loads and less-than-standard-weight bullets in cartridge cases such as the 45 Colt. I know of three valuable Colt single actions with burst cylinders and missing top straps. In all three cases the common element was a powder charge less than the minimum recommended by the manufacturer, and 200-grain bullets. You can find experts that will tell you this is possible, and others will just as strongly argue it cannot happen. I choose to stay safe and go with the former, neither loading nor recommending ultra-light powder charges or less than standard-weight bullets—especially in cartridges originally designed for blackpowder. This especially includes the 45 Colt, 44-40, and 38-40. My six-guns, lever-guns, hands, and eyes are too valuable to take chances.

All of my loads are assembled with standard pistol primers, normally CCI's #300 Large Pistol or #500 Small Pistol. CCI primers have a reputation for being harder than

others and once in awhile I will run into a single-action six-gun with a lighter-than-normal hammer fall that will not ignite the primer. Usually switching to Federal or Winchester primers will solve this particular problem. Primers are normally seated as part of the operation when using the RCBS Pro 2000 press, or seated separately using the RCBS Hand Priming Tool. The latter is of excellent quality and accepts RCBS shellholders, as well as several other brands. Since acquiring the RCBS 2000 Press I find myself using the Hand Priming Tool less and less. Even those cartridges to be charged with powder singly and then have the bullet seated using the RCBS RockChucker single-stage press are first sized, de-primed, primed, and belled on the Pro 2000. The powder measure and seating/crimping die are simply backed out so these operations are passed by.

My most used powder is Alliant's Unique as I can use the same powder charge with the 45 Colt, 44-40, and 38-40. Using bullet weights of 250 grains, 200 or 225 grains, and 180 grains respectively, and 8.0 grains of Unique, gives me loads that are very close in muzzle velocity to the original blackpowder loads of these three cartridges. They are not only enjoyable-shooting, "Clang"-producing cowboy action shooting loads, they also make excellent everyday working loads.

In addition to Alliant's Unique, I also use Bullseye, Red Dot, and to a smaller extent, American Select. From Hodgdon I go with Clays, Universal, TiteGroup, and HP-38. Winchester's WW231 and Accurate Arms' #5744 and Nitro 100 fill out my list of most used cowboy action shooting powders. I especially recommend Accurate Arms #5744 for large-capacity cartridges originally designed for blackpowder. *CAUTION:* it is not a blackpowder substitute and is not loaded with the normal charges recommended for blackpowder. I have seen one rifle taken apart because the user loaded #5744 as if it were a substitute. Follow the loading manual recommendations. It is, of course, impossible in an article of this size to list all the possible powder/bullet/cartridge combinations. In fact, to do so would take a very large volume. For our purposes here, the best we can do is look at some of my favorite and most-used loads.

When it comes to bullet selection we often have several diameters to choose from, especially in the 45 Colt and the 44-calibers: 44-40, 44 Colt, 44 Russian, 44 Special, and 44 Magnum. Oregon Trail offers 452- and 454-inch diameter 45 bullets as well as .427-, .429-, and .430-inch diameters in their 44-caliber selection. My rule of thumb is simple. I use the largest diameter that will easily chamber. Most recent Colts and Colt replicas chambered in 45 Colt seem to prefer .454-inch bullets while .452-inch is usually the best choice for Rugers. There is so much variation in 44-caliber six-gun chambers that individual experimentation is necessary. For example, I have 44-40 six-guns in all three generations of the Colt Single Action, as well as replicas of the Model P and Remington 1875. Some will accept nothing larger than .427-inch bullets while others easily chamber loads assembled with .430-inch diameter bullets. Uniformity simply

does not exist. I have yet to run into a lever-gun that would not chamber 45 Colt loads using .454-inch bullets or a 44 lever-gun that would not handle .430-inch bullets. CAS loads tailor-made for a particular six-gun with RNFP bullets can normally be expected to work well in a companion lever-gun—usually picking up 200-300 fps muzzle velocity when used in the longer-barreled lever-gun. However, some of the milder loads may only gain around 100 fps. No loads listed will exceed the 1400 fps muzzle velocity limit imposed on lever-gun loads by SASS.

I am most fortunate in my job as a gun writer to be able to test and use virtually every six-



Two excellent powders from Accurate Arms are #5744 and Nitro 100. Six-gun is Colt 1873-1973 Peacemaker Centennial 45 Colt.



Thanks to Starline and Black Hills Ammunition, all of the frontier-period cartridges are now available as brass or loaded ammunition: 45 Colt, 44-40, 38-40, 45 Schofield, 44 Colt, 44 Russian, 38 Long Colt, and 32-20.

gun and lever-gun in every cartridge chambered for cowboy action shooting. All of the loads listed have been personally used in competition. I use the word “competition” lightly as I have already expressed reasons why seriously competing with others is not all that important to me. I can add to this list the fact that I rarely shoot the same six-guns and lever-guns in any consecutive matches. There are so many guns, so many cartridges, and so much enjoyment attached to all of them. Fortunately, I am in a position to try them all. Let’s take a look at the cowboy action shooting cartridges and loads.

**The 45 Colt:** This is the cartridge adopted by the United States military in the fabled Peacemaker/the Model P/the 1873 Colt Single Action Army. The original loading of 40 grains of blackpowder when duplicated in modern solid-head brass using 40 grains of FFg blackpowder under a 255-grain bullet powered by modern CCI #350 Magnum Large Pistol Primers clocks out at over 1000 fps from a 7 1/2-inch replica of the U.S. Cavalry revolver! There is no

doubt that the original loads were in the 850-950 fps range. There were no lever-guns originally chambered in 45 Colt in the 19<sup>th</sup> century. However, those who wish to use the 45 Colt and shoot the same cartridge in both six-gun and lever-gun can choose from the Marlin 1894 Cowboy, the Winchester Model 1894, and replicas of the 1866, 1873, and 1892, all chambered in 45 Colt.

LOADS FOR THE 45 COLT	Starline Brass	Oregon Trail 250-gr. RNFP
Charge/Powder	Muzzle Velocity 7-1/2"	Muzzle Velocity 4-3/4"
17.0 gr. 5744	780 fps	620 fps
8.0 gr. Unique	925 fps	805 fps
7.0 gr. WW231	795 fps	725 fps
6.0 gr. Red Dot	855 fps	730 fps
6.0 gr. TiteGroup	790 fps	690 fps
6.0 gr. Nitro 100	855 fps	750 fps

**The 44-40:** Originally known as the 44 WCF and chambered in Winchester’s first centerfire rifle, the Model of 1873, the 44-40 was also chambered in the Colt Single Action Army with the special designation of Frontier Six-Shooter in 1878. Loads assembled with modern primers, 200-grain bullets, and 40 grains of Goex FFg blackpowder in solid-head brass deliver more than 1000 fps muzzle velocity. My favorite six-gun/lever-gun combination cartridge for CAS is the 44-40, followed very closely by the same combination using the 38-40.

LOADS FOR THE 44-40	Starline Brass	Oregon Trail 200-gr. RNFP
Charge/Powder	Muzzle Velocity 7-1/2"	Muzzle Velocity 4-3/4"
17.0 gr. 5744	850 fps	730 fps
8.0 gr. Unique	895 fps	800 fps
7.0 gr. WW231	880 fps	770 fps
6.0 gr. TiteGroup	835 fps	755 fps
5.5 gr. Red Dot	765 fps	675 fps
5.5 gr. Nitro 100	805 fps	695 fps
5.0 gr. Bullseye 100	785 fps	700 fps

**The 38-40:** The 38-40 was arrived at by necking the 44 WCF to 40-caliber in the late 1870s. Yes, the 38-40 is really a “40-40”! Sometime around 1881-1882, Colt also chambered



The four most popular cartridges in the 1st Generation Colt Single Action Army were the 45 Colt and the three Winchester centerfire (WCF) offerings of 44-40, 38-40, and 32-20. All are found in cowboy action shooting.

their Single Action Army in 38-40. Assembling original loads with modern components and solid-head brass as done with the 45 Colt and 44-40 results in a muzzle velocity of 1100 fps from a 7 1/2-inch barrel. Six-gunners were definitely not under-gunned during the frontier period.

LOADS FOR THE 38-40	Starline Brass	Oregon Trail 180-gr. RNFP
Charge/Powder	Muzzle Velocity 7-1/2"	Muzzle Velocity 4-3/4"
17.0 gr. 5744	985 fps	905 fps
8.0 gr. Unique	995 fps	910 fps
7.0 gr. WW231	910 fps	825 fps
6.0 gr. Red Dot	900 fps	825 fps
6.0 gr. TiteGroup	925 fps	830 fps
5.5 gr. N-100	930 fps	830 fps
5.0 gr. Bullseye	815 fps	675 fps

**The 44 Colt:** Once Smith & Wesson brought out their first big-bore six-gun, the 44 S&W American (*which incidentally was built under a patent held by a Smith & Wesson employee and former Colt employee, Rollin White*), Colt found themselves with enough parts to build thousands of cap-and-ball revolvers that were suddenly obsolete. Their answer was to convert existing 1860 Army revolvers to 44 Colt. The original version used a heel-type bullet partially fitted inside the case while the remainder of the bullet was the same diameter as the outside of the case. Modern 44 Colt replicas use a new version that is nothing more than a shortened 44 Special with the diameter of the rims slightly reduced to be able to fit six rounds in the rather smallish cylinder of 1860s converted to cartridge firing. It is currently chambered in replicas of both the Colt cartridge conversions and the Colt 1872 Open-Top. These are not particularly strong six-guns, with their open-top frames, and should be loaded accordingly. The 44 Colt can be loaded with 200- or 225-grain 44-40 bullets; however, for feeding through a Model 1866 or Model 1873 lever-gun the longer bullet is required to prevent the next cartridge in line from protruding through the magazine tube and into the action, jamming the lever.

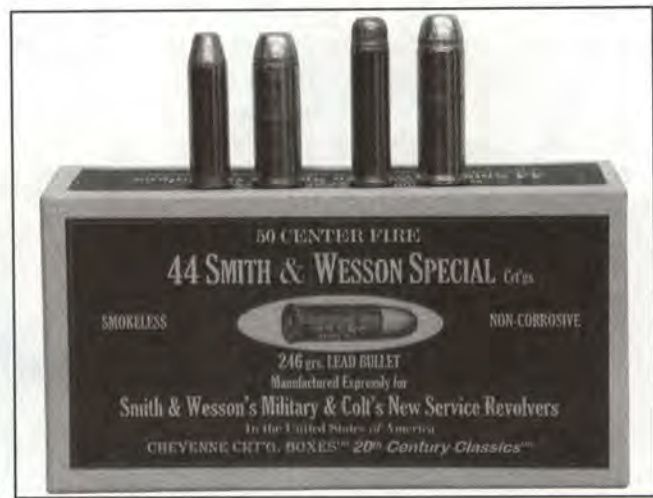

These four cartridges all appeared after the chronological period targeted by cowboy action shooting; however, the 38 Special, 44 Special, 357 Magnum, and the 44 Magnum can all be properly loaded and used in CAS matches.

LOADS FOR THE 44 COLT	Starline Brass	Oregon Trail 225-gr. RNFP
Charge/Powder	Muzzle Velocity 8"	
4.0 gr. Red Dot	660 fps	
4.0 gr. TiteGroup	705 fps	
4.0 gr. Nitro 100	605 fps	
5.0 gr. WW231	660 fps	

**The 38 Long Colt:** Colt also had 36-caliber 1851 Navy Models to convert to centerfire cartridge-firing six-guns just as they did with the 1860 Army and 44 Colt. The cartridge was the 38 Long Colt, which used a heel-type bullet. Today's replica 1851 Navy cartridge conversions are chambered in 38 Special and also marked 38 Long Colt. Starline's 38 Long Colt brass is simply shortened 38 Special brass and uses the same bullets as the Special. The 38 Long Colt is strictly a six-gun cartridge as I have not been able to get it to feed through any 357 Magnum lever-guns nor the new Marlin Cowboy Comp 38 Special Model 1894.

LOADS FOR THE 38 LONG COLT	Starline Brass	Oregon Trail 158-gr. RNFP
Charge/Powder	Muzzle Velocity 7-1/2"	Muzzle Velocity 5-1/2"
3.0 gr. Nitro 100	715 fps	695 fps
3.0 gr. Red Dot	740 fps	700 fps
3.0 gr. TiteGroup	760 fps	720 fps
3.5 gr. Unique	675 fps	635 fps

**The 45 S&W (45 Schofield):** Beginning in 1871, Col. George Schofield began to convince Smith and Wesson to upgrade their top-break Model #3 for military use by changing the locking latch from the barrel assembly to the frame, thus allowing it to be unlocked with the thumb of the shooting hand rather than requiring two hands for the operation. By 1875, the Schofield Model #3 was chambered in the military-preferred 45-caliber; due to the length of the frame and cylinder a shorter 45 cartridge was required—the 45 S&W. Colt ordered 8,000 Model #3 Schofields, as well as a large supply of 45 S&W ammunition. The new 45 S&W cartridge would work in the Colt Single Action Army chambered in 45 Colt; however, the reverse was not true,

and some outfits with Smith & Wessons wound up with the too-long-to-chamber 45 Colt ammunition. By 1878, the Schofields were being sold as surplus by the military to both civilians and Wells Fargo. Current replicas from Navy Arms are chambered in 45 Colt while the Model 2000 from Smith & Wesson is a true replica in that it handles only the 45 Schofield round.

LOADS FOR THE 45 S&W	Starline Brass	Oregon Trail 230-gr. RN
Charge/Powder	Muzzle Velocity 7"	Muzzle Velocity 5"
6.0 gr. WW231	670 fps	635 fps
5.0 gr. Red Dot	660 fps	630 fps
5.0 gr. TiteGroup	645 fps	610 fps
5.0 gr. Nitro 100	615 fps	590 fps

**The 44 Russian:** When the Russians placed a large order for Smith & Wesson Model #3s they insisted in a change of ammunition from the 44 S&W American, which used a heel type outside lubricated bullet, to a bullet of uniform diameter with lube grooves inside the case. The result was the 44 Russian. Chambered in S&W New Model #3s, it proved to be exceptionally accurate, and fathered the 44 Special in 1908 and grandfathered the 44 Magnum in 1956. It is certainly one of the greatest developments of the six-gun history scene. It is currently offered in the Navy Arms Model #3 Russian and will also work in any six-gun chambered for 44 Special or 44 Magnum, and those chambered in 44 Colt if the cylinder diameter is large enough to accept the rims of the 44 Russian. It will generally not feed through lever actions chambered in 44 Special or 44 Magnum.

LOADS FOR THE 44 RUSSIAN	Starline Brass	Oregon Trail 225-gr. NFP
Charge/Powder	Muzzle Velocity 7-1/2"	Muzzle Velocity 5-1/2"
5.0 gr. Unique	765 fps	705 fps
4.0 gr. Red Dot	825 fps	745 fps
4.0 gr. TiteGroup	800 fps	750 fps
4.0 gr. Nitro 100	740 fps	690 fps
4.0 gr. WW231	775 fps	740 fps

**The 32-20:** Looking for a lighter recoiling, flatter shooting "varmint" cartridge, Winchester came up with the 32 Winchester Centerfire which proved to be extremely popular in the Model 1873 Winchester and especially in the Model 1892 Winchester and the Colt Single Action Army and Bissley Models by 1900. It is still an excellent choice for those shooters wishing to shoot authentically but unable to handle much recoil. It is currently offered in both 1873 and 1892 replicas, has been offered in Marlin's 1894CL, and on the six-gun side is found in Model P replicas, as well as Freedom Arms Model 97.

LOADS FOR THE 32-20	Starline Brands	Oregon Trail 115-gr. NFP
Charge/Powder	Muzzle Velocity 7-1/2"	Muzzle Velocity 4-3/4"
5.0 gr. Unique	1,060 fps	955 fps
4.0 gr. Unique	810 fps	800 fps
3.5 gr. Red Dot	910 fps	895 fps
3.5 gr. TiteGroup	910 fps	905 fps

Two cartridges that arrived after the frontier period are the

38 Special and 44 Special. Both are used in six-guns chambered for the Special cartridges as well as in those made for the 357 Magnum and 44 Magnum. As mentioned, the 38 Special is the most popular cartridge for those searching for recoil-less loads and is very popular for use in Ruger's 357 Magnum Vaquero. My wife is recoil-sensitive and shoots 38 Specials in her Ruger six-guns. However, she refuses to use light loads; her favorite load being 5.0 grains of Unique and the 158-grain Oregon Trail RNFP for just under 900 fps from her Ruger Vaqueros.

LOADS FOR THE 38 SPECIAL	Starline Brass	Oregon Trail 158-gr. RNFP
Charge/Powder	Muzzle Velocity 5 1/2"	
5.0 gr. Unique	870 fps	
4.0 gr. Red Dot	840 fps	
4.0 gr. TiteGroup	925 fps	
4.0 gr. Nitro 100	830 fps	

LOADS FOR THE 44 SPECIAL	Starline Brass	Oregon Trail 225-gr. RNFP
Charge/Powder	Muzzle Velocity 7-1/2"	Muzzle Velocity 4-3/4"
6.0 gr. Unique	885 fps	780 fps
5.5 gr. WW231	815 fps	735 fps
4.5 gr. Red Dot	795 fps	730 fps
4.5 gr. TiteGroup	810 fps	730 fps
4.0 gr. Nitro 100	730 fps	635 fps

Just a few years ago, the 44-40, 38-40, and 32-20 were barely hanging on, while the 38 Long Colt, 44 Colt, 44 Russian, and 45 S&W had not been seen since before World War II. Now, thanks to cowboy action shooting, all are doing just fine and are very popular with both shooters and reloaders. Sometimes progress really does work in our favor. (For an in-depth look at the guns and loads, as well as leather, grips, and the use of cap-and-ball six-guns, the hardbound book, *Action Shooting Cowboy Style*, written by yours truly and available from Krause Publications is recommended.)

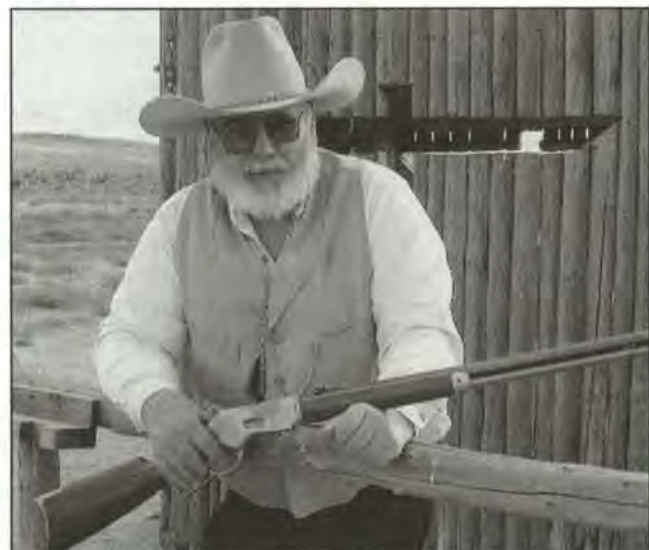

Taffin finds this Cimarron Model 1866 44-40 lever-gun to be an excellent choice for shooting either smokeless or blackpowder cartridges in cowboy action shooting.

Reloading  
blackpowder  
cartridges for  
cowboy action  
shooting.

# Old Time Cowboy Action

By JOHN TAFFIN

**BLACKPOWDER. THAT WORD** evokes many different responses. For the purist, smokeless powder is only a passing fad—and don't dare mention blackpowder substitutes! The traditionalist shoots a lot of blackpowder but is more than willing to use substitutes, while the modernist considers himself a blackpowder shooter even though using blackpowder substitutes exclusively. There are two other groups who simply will not even consider blackpowder, believing it is too difficult to load and too nasty to clean up after.

Those who think blackpowder requires so much extra effort to obtain satisfactory results usually are convinced of this by looking at, or reading about, the very precise operations blackpowder cartridge silhouette shooters must go through to be successful in their quest to knock over targets at 500 yards or more. This is a very specialized type of blackpowder shooting and much of what must be done loading for BPCS is not necessary for loading blackpowder cartridges for cowboy action shooting.



**Taffin with two pre-1900 Colt Single Action Armies, which should be used only with blackpowder or blackpowder substitutes.**

At the other end of the loading spectrum we have those who at one time maintained blackpowder was to be recommended, as it was the simplest powder for reloading. A young Elmer Keith writing in 1936 had this to say: "For the average beginner in handloading there's nothing quite so safe as blackpowder. True, it is dirty, and smoky, and fouls bores and cases badly until both have to be cleaned with hot water or solvent, but a lot of fun, satisfaction and experience can safely be obtained by its use. You can cram in all the blackpowder the case will hold, force a bullet on top of it, crimp it in any old way that holds a bullet from jumping forward and that load will go off properly and its pressures be safe. Weigh blackpowder, measure it, scoop it up, or just fill the case and strike off with a knife blade and you will still be safe. With all its faults it is by far the only powder for the novice to start with and I recommend his sticking to it until the fundamentals of the reloading game have been thoroughly learned. For the chap who shoots one of those old assembled junk-pile 45 Colts it is the one brand to stick to, because with it he can use a 250-grain lead bullet and still get about 900 feet velocity from his relic."

Now Keith was writing at a time when very few people were actually daring to enter the mystical world of cartridge reloading. So perhaps he felt his advice for using blackpowder was a simple way to get more people started reloading. At about the same time Keith was offering his advice another noted experimenter and reloader, Phil Sharpe, whose experiments—along with Keith's—led to the advent of the 357 Magnum, devoted a lot of space to express dire warnings to shooters about what a mess blackpowder shooting actually was and how one dare not even think about cleaning blackpowder firearms in the house. We've come a long way since the 1930s. Blackpowder reloading today requires a little more care than reported by Keith, and Sharpe would be happy to find cleaning is much simpler today.

In cowboy action shooting, under SASS rules, participants may use smokeless powder or blackpowder cartridges in any of the categories, Modern, Traditional, Duelist, Gunfighter, or Classic Cowboy. However, blackpowder is required to shoot in Frontier Cartridge. In this latter class, shooters may use blackpowder, or any of the approved blackpowder substitutes. As with all other categories except Modern, firearms used must be of original manufacture prior to 1896, or replicas thereof. Shooters may also use percussion revolvers in this class or they may shoot those revolvers in Frontiersman, which is reserved only for those period-styled six-guns, or Ruger's fixed-sight Old Army, requiring powder, ball, and cap.

Until recently, my blackpowder cartridges were assembled on a single-stage press and involved all the normal operations of re-sizing, de-capping, expanding the case mouth, and re-priming. Then the powder charge was placed into cases lined up in a loading block using an adjustable hand measure or flask, and then all went back to the single-stage



**Walter's Wads, when placed between bullet and powder charge, help to protect the base of the bullet and also reduce blackpowder fouling.**

press for bullet seating and crimping. Things have been much simplified with the addition of two items to my reloading bench. First is the RCBS Pro 2000 Progressive Press. This is my most used press these days, mainly because of its simplified primer feeding system that uses plastic strips holding 25 primers. The strips are fed in horizontally and are virtually foolproof. Once the strips are empty, they can be refilled using a special tool supplied by RCBS.

For using blackpowder or blackpowder substitutes, the Pro 2000 is used for re-



Some favorite replicas for shooting blackpowder are a pair of nickel plated EMF Hartford Models and a pair of Traditional Finished Model Ps from Cimarron.



Originals would be too valuable for use in cowboy action shooting, however these replicas of the Richards Conversion, Richards-Mason Conversion, and 1871-72 Open-Top are all available for shooting blackpowder loads in CAS.

sizing, de-capping, priming, and expanding the case mouth. Bottlenecked cartridges such as the 44-40 and 38-40 require lubing before sizing. For this I simply place about 100 fired and cleaned cases in a shallow cardboard tray and apply spray-on lube lightly, shake the tray, and spray again. They are now ready for re-sizing and I have not found it necessary to wipe down the cartridge cases after they go through the

progressive press cycle.

Once those four operations are completed, I switch to the second item that simplifies blackpowder loading—Lyman's relatively new #55 Blackpowder Measure. This powder dispenser is designed to prevent the possibility of a spark igniting the blackpowder in the hopper. Powder measures designed for smokeless use should NEVER be used with blackpowder, or blackpowder substitutes, due to the danger of electric sparking. The Lyman #55 Blackpowder Measure adjusts exactly as the standard #55 so many of us grew up with. A most valuable feature is the knocker on the front of the measure, which is used to assure uniformity of powder charges with no powder stuck in the drop

tube. Once my cases, which are placed in a loading block, are charged using the #55 BP Measure, I then place a wad, if desired, over the powder charge and move back to the RCBS Rock Chucker single-stage press for bullet seating and crimping. Yes, it does take longer to load blackpowder cartridges but I for one think it is time well spent. There's something soul stirring and spiritually transporting backwards





The circa-1879 44-40 Frontier Six-Shooter (center) is to be used only with blackpowder or blackpowder substitutes. It is joined by a 3<sup>rd</sup> Colt Single Action and a Cimarron Model P artificially antiqued to represent the same time period.

in time about dropping the hammer on a blackpowder cartridge and hearing the *Boom!* and then seeing the resulting smoke. When shooting outside with blackpowder cartridges the ideal situation is a mild wind to carry the smoke away. On a calm day, which we only see occasionally on our cowboy action shooting range, it only takes a couple of rounds to envelop the shooter in smoke, making sight acquisition rather difficult.

The Lyman #55 Blackpowder Measure has a removable 24-inch drop tube. The long drop is used to allow blackpowder to settle in such large capacity cases as the 45-70. It is not necessary for loading the six-gun cartridges used in cowboy action shooting. One thing I find essential for the best possible ignition when loading blackpowder cartridges is magnum pistol primers. I normally use CCI's #350 Large Pistol or #550 Small Pistol as the cartridge cases require. Blackpowder should be slightly compressed to also aid ignition and in no case should there ever be an airspace allowed in blackpowder cartridges.

The base of the bullet should slightly compress the powder charge. Refer to the manufacturer as to whether or not blackpowder substitutes should be compressed. Hodgdon recommends their Triple Seven be right up against the base of the bullet without compression. I prefer to place a vegetable wad between bullet base and powder—both to protect the base and also to help to reduce barrel fouling. Walters' Wads offers a complete line of quality vegetable wads of any diameter desired. I use them in all cartridges I load with blackpowder or blackpowder substitutes.

For the best possible results with blackpowder or blackpowder substitutes, bullets need to be of the proper alloy, proper size, and properly lubricated. This means the use of relatively soft bullets, anywhere from 1:20 to 1:30 tin-to-lead alloy, with the bullets sized to match the cylinder chamber mouths and lubricated with a special blackpowder lube such as SPG, Lyman Blackpowder Gold, Thompson's Blackpow-

der Lubricant, or Reliable #12. All of these lubes are softer than those normally used for lubing bullets for use with smokeless powder, and help to keep the barrel fouling relatively soft. Reliable #12 can be ordered in sticks for lubricating machines or cakes for melting. I use the latter for making grease cookies, which are nothing more than wads made out of lube. For this application, the cakes are melted in a shallow pan using enough for the desired thickness and then allowed to cool. The sheet of lube can then be removed from

the pan and the cartridge cases, after being charged with powder, can be used as a cookie cutter. However, unlike using a normal cookie cutter, the lube sheet is placed on the cartridge mouth and gently pressed with the thumb, placing a grease cookie inside the case, which is now ready to receive the bullet.

The Colt Single Action Army was originally, and remains, a six-gun that literally thrives on blackpowder. During the Army tests in the 1870s it was found they could shoot a Colt for 200 rounds, swab out the barrel and keep going with no other cleaning necessary. On the other hand, the Smith & Wesson and Remington single actions were ahead of their time, being built to smokeless powder tolerances in a blackpowder age. This means they would bind quickly with very few rounds being fired. With today's replicas, the Colt copies can handle just about anything, however it requires some experimentation to get either a Remington or Smith & Wesson to keep functioning during a match. Start with blackpowder with a wad, then move to the same load with a grease cookie added, and try the same types of loads with blackpowder substitutes. With a little experimenting with loads one should be found that will not bind up a Smith & Wesson or Remington. Perhaps this is why the Colts were the most popular six-guns on the Frontier.

If one does not cast bullets there are several options. Black Dawg offers properly alloyed and properly lubed bullets for the best possible results with blackpowder cartridges. Time I used to spend carefully alloying tin and lead, casting, and then lubing and sizing, can now be spent doing other things thanks to these bullets offered by Black Dawg. What about using commercially-cast bullets, which are normally harder than those which give the best results with blackpowder? They can be used, and rather successfully within limits. Meister Bullets offers their standard cast bullets lubed with SPG. They will not normally work as well as softer alloys but they are adequate for cowboy action



Cowboy action shooters also use the Winchester 1892 and 1894, as well as the Marlin 1894, with blackpowder loads.

shooting, with some special steps required during the match or while shooting large quantities of ammunition.

I also use a lot of the standard hard-cast, hard-lubed, bevel-based bullets as offered by Oregon Trail Bullet Co. With these I always use a wad between powder and bullet and also keep a cleaning rod handy for swabbing the barrel between stages. While using the best possible soft bullet and soft lube may get you through a complete match without ever clean-

ing the barrel, it is not going to happen using normal hard cast bullets—even those lubed with SPG. In addition to running a cleaning patch down the barrel I also find it necessary to clean the front and rear of the cylinder.

All of this is much easier than it sounds thanks to Windex. I keep a spray bottle handy for thoroughly soaking the patches used in the barrel between stages and I also spray a generous amount at the front and back of the cylinder with-

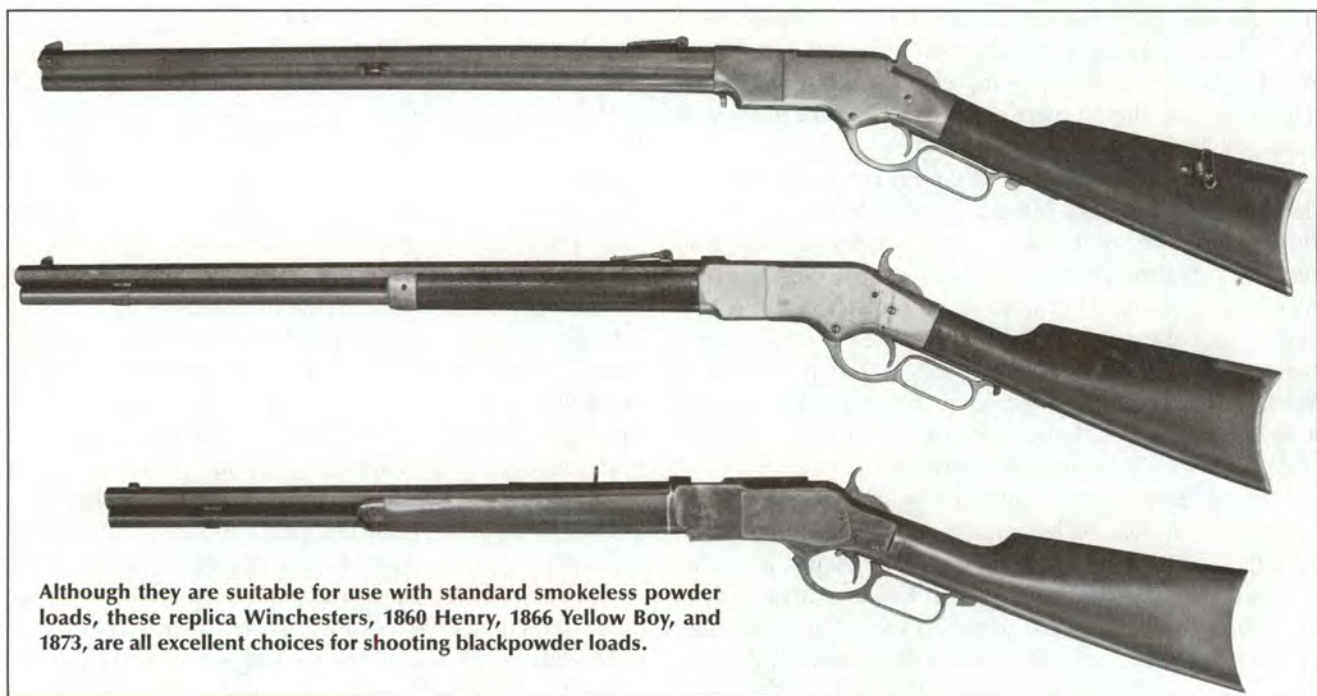

Although they are suitable for use with standard smokeless powder loads, these replica Winchesters, 1860 Henry, 1866 Yellow Boy, and 1873, are all excellent choices for shooting blackpowder loads.



These original blackpowder cartridges are still very popular with blackpowder shooters. The 45 Colt, 44-40, 38-40, 32-20 were all chambered in the Colt Single Action Army; however, only the latter three were found in Winchester lever-guns. All are loaded with Oregon Trail's RNFP bullets.

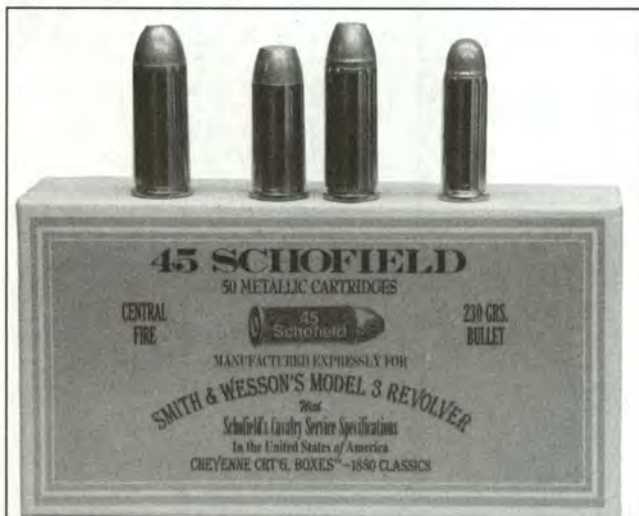

Four blackpowder cartridges, originally chambered in Smith & Wesson single actions and Colt cartridge conversions, still in use today in modern replicas are the 45 Schofield, 44 Russian, 44 Colt, and 38 Long Colt loaded with Oregon Trail bullets.

out removing the cylinder. When the match is over, I remove the cylinder, swabbing out with Windex, run another patch down the barrel, spray the entire six-gun as well and then wipe down with a paper towel. When I arrive home all the firearms used for blackpowder shooting are then thoroughly cleaned with special blackpowder cleaners such as Hoppe's #9 Blackpowder Solvent or Black Dawg's Dawg Whizz. A Q-Tip soaked in solvent is used in the hard-to-reach places in the cylinder window, the cylinder ratchet, and the bolt notches. After every third match, firearms are completely dismantled and all parts thoroughly cleaned. When swabbing the barrel of a lever-gun I leave a fired case in the chamber to prevent the dirty wet fouling from working its way into the action.

It still does take more time to clean blackpowder firearms. I figure I spend about 20 minutes on each one after a match,

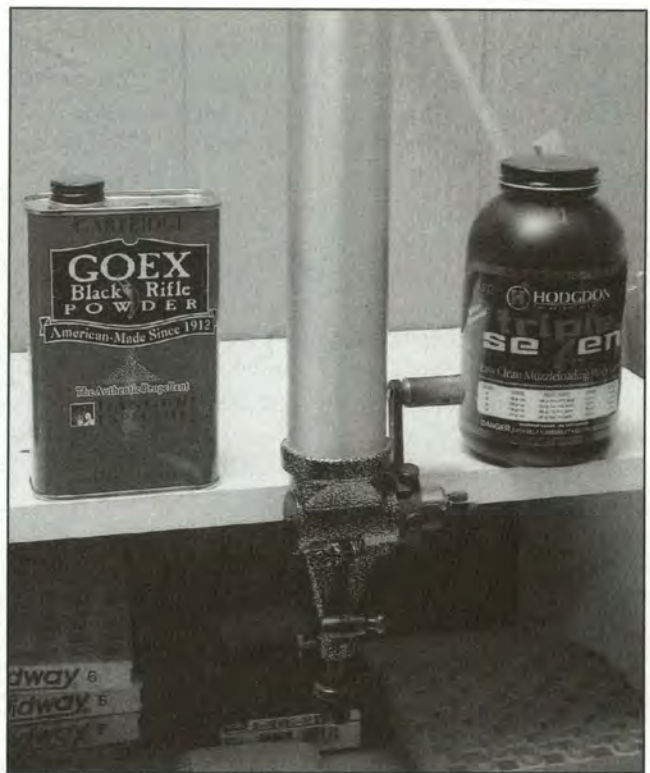

Lyman's #55 Blackpowder Measure is specially designed for use with blackpowder and blackpowder substitutes.



The Lyman #310 Tool is used to de-prime blackpowder cases which are then dropped into a gallon jug of soapy water to begin the cleaning process.

with much more time being required for total dismantling and cleaning of the inner parts. Most smokeless powder guns simply require a wiping down before being placed back in the safe. I do not clean these guns thoroughly until absolutely necessary. Blackpowder guns must be cleaned after every use; smokeless powder firearms do not require this

great care. Generally speaking, blackpowder substitutes will produce less fouling and have less corrosive action on barrels and cylinders. However, it is still required that all firearms—whether loaded with blackpowder or blackpowder substitutes—*MUST* be thoroughly cleaned after a match.

Fired cartridge cases, whether used with blackpowder or blackpowder substitutes, require special attention. My first loading tool back in the mid-'50s was the Lyman #310 nutcracker style hand tool. It is still in use; however, it is used only for de-priming blackpowder cartridges. After a match all primers are popped out using the #310 and then placed in a gallon jug of soapy water. The ride home sloshes the empty cases around, beginning the cleaning process. After arriving at home the dirty water and cartridge cases are dumped in the kitchen sink and then sprayed with the hose attachment on the sink. The cases are then removed from the sink and placed on newsprint to dry, and a Q-Tip is used to remove the black crud from the primer pockets. Cases are then placed in a large Dillon Vibratory Case Cleaner, along with any cases used with smokeless powder that may also need to be cleaned.

rent blackpowders available include Goex, Elephant Brand, Swiss, and Wano. Blackpowder substitutes available to me have been Clean Shot, Hodgdon Pyrodex and Triple Seven, and Goex's Clear Shot. Blackpowder is rated by the size of the granules with Fg, 1-1/2Fg, FFg, FFFg, and FFFFg



RCBS's Cowboy dies are designed with a pre-1900 look and also to perform best with cast bullets.

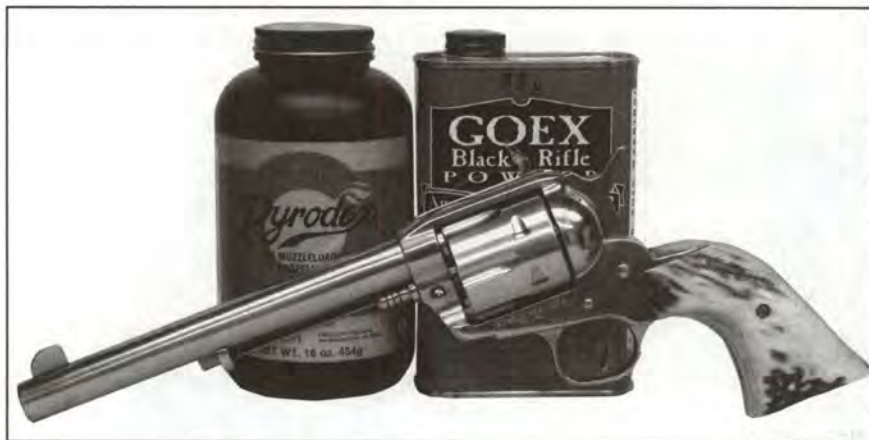

Although it is a modernized version of the traditional single action, Ruger's Vaquero performs very well with blackpowder.

normally being available with the larger the F-number, the finer the granules, and the faster burning the powder. For loading six-gun cartridges for use in six-guns or lever-guns I use FFFg for 38- and 32-caliber cartridges, and either FFg or FFFg for anything from 38-40 and larger. FFFg will normally give higher velocities than FFg. Goex also offers a powder grade, Cartridge, for use in cartridges as opposed to muzzleloaders. It normally gives lower muzzle velocities than either FFg or FFFg.

When the cleaning is accomplished I know which are blackpowder cases by the fact they have already have the primer removed. The flash hole will often be clogged with cleaning media; however, this will be removed automatically when the cartridge cases are run through the sizing/de-capping die.

The brand of blackpowder used may be dependent upon what is carried by your local gun shops. We are fortunate in my area to also have a very active blackpowder club, Ec-Da-How Long Rifles, which maintains a blackpowder supply for sale to members. Cur-



This 1879-era Colt Single Action is used only with blackpowder, such as that offered by Goex.

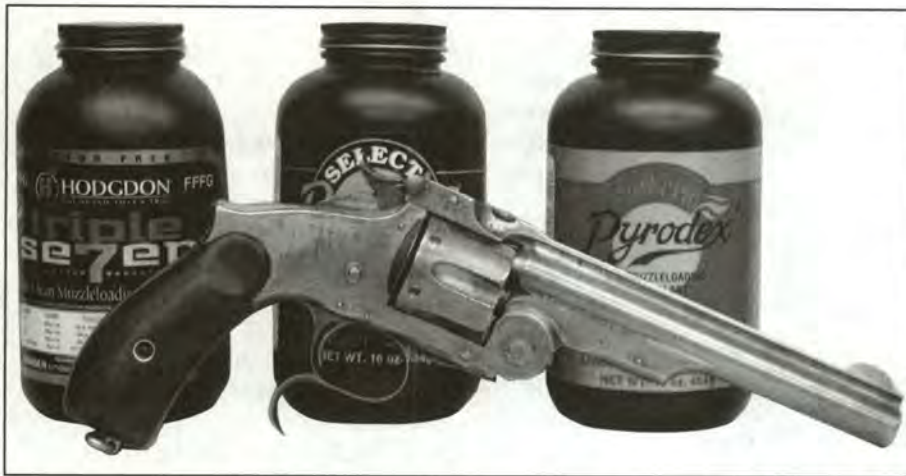

**Hodgdon offers blackpowder substitutes less prone to fouling the actions of original, or replica, Smith & Wesson Model #3s.**

Cor-Bon and Ten-X have old-style cartridges available loaded with blackpowder substitutes. We also have replica six-guns and lever-guns, as well as originals, for shooting blackpowder cartridges, and there's nothing that says we cannot shoot blackpowder even in Ruger Vaqueros and currently produced Colt Single Action Armies.

Thanks to Starline we have eight 19<sup>th</sup> century cartridge cases, and we also have six-guns to handle them, now available for the blackpowder shooter. These are 45 Colt, 45 S&W, 44 Russian, 44 Colt, 44-40,

I do not use nor recommend any fillers for loading blackpowder cartridges. One can control both recoil and muzzle velocities by powder choice. For example the same amount of Elephant Brand will give less recoil and muzzle velocities than a like amount of Goex. When one looks at the blackpowder substitutes, Triple Seven when loaded with the same volume as Pyrodex will generally give higher muzzle velocities. If recoil is deemed to be too high with 45 Colt loads no matter what powder is used for full loads the answer is not to try to produce light loads but rather work one's way down the cartridge scale from 45 Colt to 45 S&W or 44-40

to 38-40 to 44 Russian or 44 Colt or even 38 Long Colt or 32-20. I shoot all of the first six cartridges mentioned often depending upon which firearms I happen to be testing while my wife uses 38 Specials loaded with 158 grain bullets and Triple Seven in her custom Vaqueros.

All powders are loaded by volume not by weight. The correct volume is enough powder to fill the case slightly above the base of the bullet thus allowing some compression. This is true for all blackpowders regardless of brand or granulation, again however, some blackpowder substitutes manufacturers will advise that the powder should not be compressed but simply loaded even with the base of the bullet. Follow the manufacturer's directions.

Although blackpowder cartridges were generally available up to the eve of World War II, blackpowder use was basically dead except for muzzleloading. Very few, if any, six-gun cartridges were available loaded with blackpowder until very recently. Today, thanks to Cowboy action shooting, at least two manufacturers offer authentic blackpowder loads, those two being Black Dawg and Wind River, while



**Two blackpowder substitutes especially suitable for use in tightly-fitted Smith & Wessons are Clean Shot and Goex Clear Shot.**

38-40, 38 Long Colt, and 32-20. By the time you read this 41 Long Colt brass should also be available. Although they are not in the pre-1898 time frame covered by cowboy action shooting, both the 38 Special introduced in 1899 and the 44 Special from 1908 were both originally loaded with blackpowder and can certainly be used today. Even the modern magnums—357 and 44 Magnum, both simply being elongated Specials—can also be loaded with blackpowder or a blackpowder substitute. Lever-guns available are chambered in 45 Colt, 44-40, 38-40, 44 Special, 38 Special, 357 Magnum, and 44 Magnum. The 45 S&W will work in most 45 Colt rifles. I have yet to find a lever-gun that will feed either the 44 Russian or the 38 Long Colt.

The original loadings for the 45 Colt, 44-40, and 38-40 all used 40 grains of blackpowder. Bullet weights were 255, 200, and 180 respectively. The original brass did not have a solid inner base as the primer pocket protruded above the rather thin base. These old cartridge cases had more capacity than current solid head brass and could accept the full 40-grain charge. These three loads, when assembled in old-style

brass and loaded with current blackpowder using a modern Magnum primer for ignition, give some rather startling results. When fired from 7-1/2" six-guns, both the 255-grain 45 Colt load and the 200-grain bulleted 44-40 load exceed 1000 fps muzzle velocity, while the 38-40, with a 180-grain bullet, clocks out at over 1100 fps. These are not light loads by anyone's reckoning. In fact, the military quickly found the 40-grain load too much to be handled by most troopers and it was dropped to 30 grains, while the civilian 45 Colt leveled off at 35 grains.

With all the replicas of Colts, Smith & Wessons, Remingtons, and Winchester's available CAS participants have a choice of using blackpowder or smokeless powder. However, original six-guns and lever-guns design for blackpowder use should only be used with blackpowder or blackpowder substitutes. To stay on the safe side I use either blackpowder or a blackpowder substitute in any firearm made before 1900. Hodgdon publishes pressure data for Triple Seven in the 5th Edition of their Cowboy Action Data pamphlet (*free for the asking*) and it is very assuring to know just what I am dealing with in loads for valuable 1st Generation Colt Single Actions and Smith & Wesson top-breaks.

Sample Blackpowder Loads: All loads are by blackpowder measure volume—not by weight—and are assembled with flat-nosed bullets for safe use in lever-gun tubes. These bullets are generally referred to as RNFPs or round-nosed flat-points. Some loads use RN or round-nosed bullets. These are for use only in six-guns. All bullets are available in bulk quantities from such companies as Oregon Trail Bullet Co.

### 45 Colt

Bullet	Load	MV 7-1/2" Barrel
250 gr. RNFP	35.0 gr. FFg	870 fps
250 gr. RNFP	35.0 gr. FFFg	920 fps
250 gr. RNFP	35.0 gr. Cartridge	835 fps
250 gr. RNFP	35.0 gr. Pyrodex P	930 fps
250 gr. RNFP	30.0 gr. FFg	775 fps
250 gr. RNFP	30.0 gr. FFFg	810 fps
250 gr. RNFP	30.0 gr. Cartridge	795 fps
250 gr. RNFP	30.0 gr. Pyrodex P	835 fps

### 45 S&W (45 Schofield)

Bullet	Load	MV 7-1/2" Barrel
250 gr. RNFP	25.0 gr. FFg	735 fps
250 gr. RNFP	25.0 gr. FFFg	805 fps
250 gr. RNFP	25.0 gr. Cartridge	715 fps
250 gr. RNFP	25.0 gr. Pyrodex P	790 fps

### 44-40 (44 Winchester Centerfire, or 44 WCF)

Bullet	Load	MV 7-1/2" Barrel
200 gr. RNFP	35.0 gr. FFg	860 fps
200 gr. RNFP	35.0 gr. FFFg	895 fps
200 gr. RNFP	35.0 gr. Cartridge	830 fps
200 gr. RNFP	35.0 gr. Pyrodex P	1,000 fps
200 gr. RNFP	30.0 gr. FFg	790 fps
200 gr. RNFP	30.0 gr. FFFg	805 fps
200 gr. RNFP	30.0 gr. Cartridge	755 fps
200 gr. RNFP	30.0 gr. Pyrodex P	850 fps

### 44 Colt

Bullet	Load	MV 7-1/2" Barrel
200 gr. RNFP	25.0 gr. FFg	770 fps
200 gr. RNFP	25.0 gr. FFFg	845 fps
200 gr. RNFP	25.0 gr. Cartridge	720 fps
200 gr. RNFP	25.0 gr. Pyrodex P	875 fps

### 44 Russian

Bullet	Load	MV 7-1/2" Barrel
250 gr. RN	20.0 gr. FFg	695 fps
250 gr. RN	20.0 gr. FFFg	745 fps
250 gr. RN	20.0 gr. Cartridge	655 fps
250 gr. RN	20.0 gr. Pyrodex P	775 fps

### 38-40 (38 Winchester Centerfire, or 38 WCF)

Bullet	Load	MV 7-1/2" Barrel
180 gr. RNFP	35.0 gr. FFg	975 fps
180 gr. RNFP	35.0 gr. FFFg	1,045 fps
180 gr. RNFP	35.0 gr. Cartridge	925 fps
180 gr. RNFP	35.0 gr. Pyrodex P	1,120 fps
180 gr. RNFP	30.0 gr. FFg	950 fps
180 gr. RNFP	30.0 gr. FFFg	975 fps
180 gr. RNFP	30.0 gr. Cartridge	960 fps
180 gr. RNFP	30.0 gr. Pyrodex P	910 fps

### 38 Special

Bullet	Load	MV 5-1/2" Barrel
158 gr. RNFP	20.0 gr. FFg	760 fps
158 gr. RNFP	20.0 gr. FFFg	845 fps
158 gr. RNFP	20.0 gr. Cartridge	725 fps
158 gr. RNFP	20.0 gr. Pyrodex P	830 fps

### 44 Special

Bullet	Load	MV 7-1/2" Barrel
250 gr. RN	25.0 gr. FFg	765 fps
250 gr. RN	25.0 gr. FFFg	815 fps
250 gr. RN	25.0 gr. Cartridge	705 fps
250 gr. RN	25.0 gr. Pyrodex P	850 fps

Yes, loading cartridges with blackpowder or blackpowder substitutes requires more time and more steps than loading with smokeless powder; yes, cleaning firearms shot with blackpowder or blackpowder substitutes not only requires cleaning after each use but also a more thorough cleaning than those firearms used with smokeless powder; and yes, it is messy and dirty, with a unique smell. Firearms, hands, and clothes will all be affected by blackpowder fouling and residue to some extent. Is it all worth it? I think it is and I'm definitely not alone.

For a more in-depth look at reloading and shooting blackpowder cartridges than this space allows, the reader is referred to the hardcover book, *Action Shooting Cowboy Style*, by yours truly and published by Krause Publications.

In all probability, more shotgun shells are fired at clay targets than in any other sport. And most shooters get into reloading because of the expense of shooting high-quality target loads.

# Reloading for the Clay Sports

By BOB KRAWCZYK

**TO STATE IT SIMPLY**, they do it to save money. Too many times, they get the cheapest components they can to save money. But, as they progress in the particular clay game of their choice, they find that they can duplicate the performance of the better shells, be they AAs, STS, Gold Medals, or any of the other brands by “rolling their own” with somewhat better components for just a little more cost. For more pleasant shooting, they can tailor their loads to give a substantial reduction in recoil - and avoid the dreaded “flinch” while still breaking targets effectively. Or, as another example, they can tailor their loads for a variety of targets and distances as encountered in sporting clays.

Let's look at some specific examples. Skeet targets are generally taken at an average range of 20 yards. But you are shooting at Station 8 at Skeet, and targets are broken somewhere between 5 to 10 yards. For the beginner (and even some of us “veterans”) the targets seem to come out of the house at a high rate of speed, and you have to break the target quickly, but you have to break them at

close range with a tight pattern because it is at much closer range than the other targets encountered. You can increase your short-range pattern size somewhat by using "Spred-R" overshot wads in a couple of shells that you have loaded specifically for the task beforehand. It does make a difference.

Another example is in shooting trap - for 16-yard targets, the average range where you break a target is a lot different than if you are shooting from the 27-yard line! Do you necessarily want to use the same loads? Or, in sporting clays, you are faced with a variety of different sized targets at ranges from "very close" to "far". And the targets vary in size, "physical toughness" and ease of breaking. In other words, pattern density and pellet size and energy should be considered for each target presentation to get best results. Maybe I am over-complicating it, but I know my scores and the scores of others have improved by considering this.

One thing will impress new shooters is, in a break of shooting activities, to go out to where the targets fall and look at the "missed" targets. Virtually all I have ever looked at have pellet holes and chips from pellets in them! They were actually hit, and usually by two or more pellets! It is a combination of pattern density and energy that breaks clay targets.

By reloading, we can "tailor" our loads to take care of some of these problems.

So what steps are required to reload for the clay games? Well, let's start off with **SAFETY**. And, in my humble opinion, the first piece of equipment any reloader should buy, even before getting reloading equipment, is a good, accurate scale of adequate capacity to measure both powder charges and shot charges. Either a manual "balance beam" or a digital type is fine. While the digital scale is more expensive, it is much faster and more convenient, and if you are reloading for a variety of cases or using different powders and charges, it will be a major advantage to invest the money. A word of caution, however. I set my electronic scale on a small table on my right side (I am right-handed) when reloading. I do this, as it keeps it isolated from the continuous jarring of the reloading bench, so I don't have to keep re-calibrating it.

I don't believe in powder and shot bushing charts, as they usually are close, but can vary substantially based on your physical reloading process: how stable your bench is, how hard you "pull the handle", how full your powder or shot reservoir is, how the powder/shot drops on your machine, and a variety of other factors. Get your reloading "rhythm" down to a consistent routine, and major variations will disappear. But weigh the charges of both shot and powder often enough (*and especially when using a new lot of powder*) to be sure. To me that is the first step in reloading safety, and for any firearm. Then, just follow the other rules of reloading safety: never mix different powders together, keep open flame and electricity at a distance, inspect cases before loading, discarding all defective cases, keep records of the case life and reloading data, and follow precisely the load recipes recommended by the powder manufacturers exactly. Do not vary from them.



**It is good practice to inspect each case before reloading to assure that it is in good shape, free from pinholes, crimp defects, and free from other defects. Any suspect cases should be discarded.**



**All set to call for the target at Skeet. Hearing protection, shooting glasses on, head down on the stock, relaxed stance, and confidence in my reloads' performance makes for good shooting.**

If you happen to own a MEC reloader, you can purchase a universal, adjustable powder and shot bar. While not manufactured by MEC, these fit perfectly, and they are available at most suppliers. They have micrometer-type adjustments, and I use mine when I am setting up for new loads for testing. These are available in different models for single-stage presses, or progressives. These save you a lot of buying, storing and "adjusting" powder bushings by either taping the inside, or filing and polishing the inside, then keeping track of what you adjusted them to do.

Always, always, always make sure you wear shooting glasses and hearing protection at all times when reloading and shooting!

Now let's get into reloading for the different games. Let's



start off with Skeet. Skeet is a close-range game, with shots normally about 20 yards, and at all kinds of angles to the shooter. It is a game of open-choked guns - Cylinder, Skeet or Improved Cylinder chokes all work. In fact, I often shoot an old (but safe) blackpowder hammer double with Cylinder-bored barrels with light blackpowder reloads for Skeet just for fun, and with good success.

Milder loads are often used for Skeet. If, for example, you have used Winchester AAs in their Light 2-3/4 dram equiv. loading in your 12-gauge, and have good results, why not duplicate it? The easiest way is to use your empty AA cases, and use Winchester components: Winchester 209 primers, WAA12 wads, WST powder, and the so-called "magnum" (hard) shot in No. 9, as follows:

**Case:** Winchester AA 2-3/4" 12-gauge shell

**Primer:** Win. 209

**Powder:** 18.5 grains Winchester WST

**Wad:** Win. WAA12

**Shot:** 1-1/8 oz. hard 9 shot

**Vel:** 1145 fps

**Press:** 8600 psi

This is Winchester reloading data; one of the many loadings listed in the Winchester Components Catalog, and the footnote states "This load will duplicate the ballistics of the factory Winchester AA Light 2-3/4 dram eq. target load." In addition, there are other loads listed to duplicate many of their target other loadings.

To duplicate this and the similar and excellent Remington STS loading with different (Remington) components and Alliant powder, here is a loading that works very well:

**Case:** Remington STS 2-3/4" 12-gauge shell

**Primer:** Rem. 209P

**Powder:** 19.0 gr. Alliant Green Dot

**Wad:** Rem. Fig. 8

**Shot:** 1-1/8 oz. hard 9 shot

**Vel:** 1145 fps

**Press:** 7,300 psi

**Ref:** *Alliant Powder Reloaders' Guide*

And here is the recipe for Federal Gold Medal:

**Case:** Federal Gold Medal 2-3/4" 12-gauge shell

**Primer:** Fed. 209A

**Powder:** 19.5 gr. Alliant Green Dot

**Wad:** Fed. 12S3

**Shot:** 1-1/8 oz. hard 9 shot

**Vel:** 1145 fps

**Press:** 8,100 psi



The clay games are family sports. Here, a whole family is shooting registered Skeet and enjoying themselves. For the kids, the Dad keeps loadings light so they don't get battered by recoil, and will continue wanting to shoot.

**Ref:** *Alliant Powder Reloaders' Guide*

These are simply some examples. All the powder manufacturers make suitable powders for reloading shotgun shells. Hodgdon and their clean-burning Clays family of powders are excellent, as are Accurate, IMR (*now a division of Hodgdon Powder*), Ramshot, Vihtavuori, and others, while CCI and Focchi make excellent primers, and the many wad manufacturers make suitable wads for the particular shell you reload. The data for using any and all of these combinations are available primarily from the powder manufacturers.

In addition, I stated that I use a special "spreader" loading for shooting close-range targets (like Station 8 at Skeet). The load I use is made up in the following recipe:

**Case:** Winchester AA 2-3/4" 12-gauge shell

**Primer:** Win. 209

**Powder:** 20.0 gr.

**Wad:** WAA12

**Shot:** 1 oz. chilled 9 shot

topped with a Poly Spred-R 12-ga. over-shot wad

**Vel:** 1215 fps

**Press:** 10,500 psi

This is an "old favorite", recommended by the late, great Don Zutz, and as tested by Alliant Powder's predecessor, Hercules. It is an excellent choice for wider patterns on close shots. It is effective whether used with tight or open chokes, and also can be used to shoot Skeet with a tightly-bored gun. But how do I keep these segregated so I can tell them apart from my regular Skeet loads? Well, I use color-coding, and various pockets in my shooting vest. I use the silver-colored AA shells (used in their handicap loads) to tell them apart from the rest of my shells (Regular AAs are red.). It works! Of course, many other "color codes" exist just by changing brands.

In addition, there are similar recipes and formulas for loading 20, 28, .410, and yes, you can even make quality target loads for your old, favorite 16-gauge. All you have to do

is read the manuals, and follow the recipes exactly.

Just three more notes on my part. Try using chilled shot in place of the hard shot for Skeet. You will probably find, as I did, that you are breaking more targets. Yes, the softer shot gets deformed more in shooting, but with average shot distances of 20 yards, they are still holding within the main shot charge for the most part, and usually fill in the weaker outside "rim" of the pattern. But I always use and recommend hard shot for the balance of my clay shooting and hunting.

Secondly, if you are doing some informal target shooting, with a hand trap or one of the small, portable traps, you will find that the Skeet recommendations will serve you well. Open chokes and light loads are the right way to go, especially in training new shooters. This is one of the important aspects of the clay shooting games, and teaching the new shooter, and the informal "hand trap" coupled with a few close friends or family helps them avoid the embarrassment of missing in front of crowds. It also prevents the proverbial "too much advice" given by well-intentioned "experts".

Thirdly, always pattern your loads when you make a change. Patterning is easy, and can tell you a lot about your specific gun and its preferences. As many people have stated, "Each shotgun is a law unto itself". What works well in another gun may not work in yours!

Another important fact to remember is that if you are becoming recoil sensitive (*occasionally flinching*), try the light loads of 1-ounce, 7/8-ounce and even 3/4-ounce of shot in the 12-bore and watch the flinch disappear. The game of International Skeet requires "24 gram" loads. These contain 12-1/2 grains less shot than a 7/8-ounce load! And these folks are good - the targets are faster, they start with "gun down", and many target presentations are *doubles!* The second target in doubles is usually at longer range, too, and yet these targets break very well. So, why do we insist on pounding our shoulders with heavy powder and shot loads?

My personal favorite low-recoil load is a 7/8-ounce loading in the 12-gauge. Recoil is reduced from a "wallop" to a "nudge" and shooting is totally pleasurable. The occasional flinch even stops. Going from 1-1/8 ounce to 7/8-ounce loading at the same velocity (1200 fps), the calculated recoil in my 7-1/2 pound gun resulted in a recoil reduction - 19.02 ft. lbs. for the 1-1/8 load down to 11.99 ft. lbs. for this 7/8-ounce load. Best of all, the birds still break well, my shoulder doesn't get sore, and my average went UP! Now THAT'S what I call "shooting in comfort". In addition, these make excellent loads for introducing newcomers to shooting!

Here is the light 7/8-oz. load that is my favorite for Skeet. Give it a try and watch your flinches go down, and your averages go up.

**Case:** Winchester 12 gauge AA case

**Primer:** Win 209

**Powder:** 16.5 gr. Red Dot

**Wad:** WAAL (gray)

**Shot:** 7/8 oz. 9 chilled

**Vel:** 1200 fps



An informal shoot. This lad is using a 7/8-oz. load in his 12-gauge for low recoil, and in the previous round he broke his first 25.

**Press:** 7,900 psi

**Source:** *Alliant Powder Reloaders' Guide*

Also, there are loadings equally good for all brands of shells, powder and wads. Check out the powder manuals. You just have to experiment a little. Just remember one general rule - faster burn rate powders work best for light loads, and give more consistent results.

By the way, good crimps really affect shotshell performance, and are especially important on light loads. Good crimp depths are considered 0.050- to 0.060-inch. Don Zutz reported this in the book, *Hodgdon Powder Shotshell Data Manual*. Hodgdon tested this variable, and the load used was:

**Case:** Winchester 12-gauge AA case

**Primer:** Win 209

**Powder:** 20.0 gr. Hodgdon Clays

**Shot:** 7/8 oz. lead shot

(Wad was not specified)

Results of testing were:

Crimp Depth	Velocity	Pressure
0.030"	1308 fps	9,300 psi
0.050"	1329 fps	10,500 psi
0.070"	1351 fps	11,900 psi
0.090"	1363 fps	13,100 psi

The lesson is obvious. Always take care to obtain good, uniform crimp depth of 0.050" to 0.060" on your reloads.

Does shot velocity affect lead? Well, actually yes - but it's not that big a deal. Let's look at Skeet, 20 yards, full crossing shot (station 4), and the difference of where the center of the pattern would fall compared to 1150 fps velocity as a "standard". This shows that velocity is not a "big deal", and even if you had a "faster" load, you still wouldn't break a target you shot behind!

Velocity	Lead	Change in lead
1100 fps	41.23"	+ 1.79"
1150 fps	39.44"	0
1200 fps	37.80"	- 1.64"
1250 fps	36.29"	- 3.16"

**Source:** Hodgdon Powder

Yes, I could go to a smaller gauge to shoot standard loads ... but the problem is that smaller gauge guns are lighter weight guns, and in many cases, the calculated recoil (*and "felt kick"*) is as bad as (*or worse than*) heavier 12-gauge guns shooting normal loads! I dearly love the smaller gauges, and use them regularly. But to train a new shooter, and for a recoil-sensitive guy (*or gal*) I would start with a heavier 12-gauge gun, and use my tailored light loads to duplicate their performance, and make their shooting a pleasure, not an ordeal.

But to reiterate, pattern your Skeet guns with your "experimental" shells at 20 yards to determine their effectiveness in your gun for Skeet. And use the loads that pattern best in your gun. Ideally, you should get a full 30-inch evenly dispersed pattern, with no holes in the pattern.

Remember, too, you can also reload for your 10-, 16-, 20-, 28-gauge or .410-bore guns as well as the 12. Data and components are readily available for them. In this chapter I concentrated on the 12-gauge, the gauge I see used at the range most often. But I do use all of the gauges, and reload for them. And the choice is yours, for all these guns can and do break targets very well.

Okay, now let's talk about the great game of trapshooting. In this sport, targets are generally presented going away, initially rising, and at a variety of "random" angles. As a result, they are generally taken at longer range - between 30 and 35 yards, and just prior to starting to descend. To get the proper breaks on clay birds, tighter chokes (Modified to Full, depending on the shooter's preference), larger shot (7-1/2s), and, generally, higher velocities to have sufficient energy to break targets. Shooters generally stand back of the trap house so the distance is 16 yards, but depending on their scores, shooters may be "handicapped" at distances out to the 27-yard line behind the trap house. So birds are taken at ranges approaching 40 yards - sometimes even a little more. This, of course, requires tighter choking and 12-gauge guns for most people.

The rules for "legal" amounts of powder and shot in loads are not understood by lot of people. I just checked the rulebook, and here they are, in simplified form.

Muzzle velocity of shot charge, max.	Maximum weight of shot allowed
1290 fps	1-1/8 oz.
1325 fps	1 oz.
1350 fps	7/8 oz.

In other words, the velocity (*thus, powder charge*) affects the maximum amount of shot you can use. (Note: Most shooters do not load to the maximum velocity.)

Here is a "standard" typical all-around "handicap" trap

loading that works well:

**Shell:** Winchester AA 2-3/4" 12 Gauge

**Primer:** Win 209

**Powder:** 18.1 gr. International Clays

**Wad:** WAA12

**Shot:** 1-1/8 oz. hard 7-1/2s

**Vel:** 1200 fps

**Press:** 8,300 lup

**Source:** *Hodgdon Basic Reloaders Manual*

Of course, similar loadings are available for all other brands of shells, and a selection of components, as well.

Although shooters generally swear by 7-1/2s for shot size and "Handicap"-type heavy loads, lighter loads and smaller sizes can be used to improve pattern density and target breaks, and I suggest you try 8s and 8 1/2s in lighter 1 ounce loads as well to see which size works best for you and the ranges at which you normally take your targets. "Max" loads and their higher velocity (and kick) are not usually required at the 16-yard line. We get too ingrained in the attitude, "We always did it this way", and the dreaded flinch starts creeping in. A little experimentation with lighter loads just may make a difference for you!

As most shooters use the 16-yard line for the majority of practice sessions, a hard-kicking heavy load isn't really needed. So a lighter load makes sense. Try 'em both ways, using a standard "handicap" load for a round, then a lighter load that you have patterned and tested in the next round to determine the difference. If you shoot informally, this will give you the most comfortable load to shoot, and you will probably see your scores improve.

For the handicap events, especially where the longer ranges are concerned, we need to pay attention to tighter chokes, retained velocity and individual pellet energy for consistent target breaks. Many shooters use "super handicap" (at a velocity of about 1250 fps) loadings and the largest shot (7-1/2) to compensate for this. But again, try cutting back on the powder charge to save your shoulder, and improve your shooting. It just may keep you from becoming a premature "old-timer" that has to rely on a "release trigger".

And, reiterating, pattern your loads and trap guns at the same distance as you normally break your birds - usually 30 to 35 yards, and use these patterns as a guide for the loads you use.

Now, let's look at sporting clays. This game basically throws "fixed" presentations, trap placement, target distance and direction out the window. There are very few rules as far as these aspects are concerned - and in many cases, you will find that some "fiend" dreams up the presentations—which look easy—but are guaranteed to make shooters miss! To make it even more difficult, the guys setting up the targets for a given station usually modify them every week or so. And, targets vary in size and type. I don't know how many times I have heard people exaggerating, complaining about having to shoot "aspirin tablets at 40 yards", or similar comments, usually unprintable. And wooded areas, trees, brush and other "obstructions" are part of the scene, as well as



I am shooting my Granddad's old 12-gauge 2 9/16-inch chamber length blackpowder Cylinder-bored hammer gun. Inspected and safe for blackpowder loads, it breaks birds well, and makes for an interesting conversation piece. Everyone wants to shoot it!



A grouse-type shot at doubles in fairly heavy cover, at reasonably close range. For this type of shooting, light loads are recommended for fast recoil recovery for the second shot.

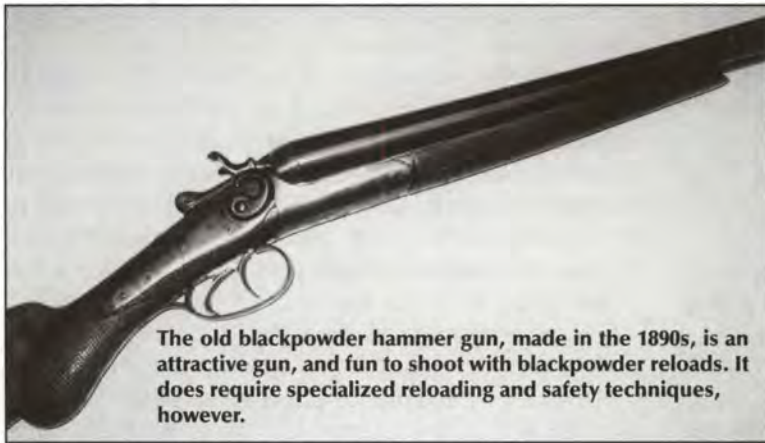

The old blackpowder hammer gun, made in the 1890s, is an attractive gun, and fun to shoot with blackpowder reloads. It does require specialized reloading and safety techniques, however.

open fields, plus shooting uphill, downhill, and every presentation you can imagine. And, usually there is a lot of walking involved, moving from station to station. A lot of folks call the sport "golf with a shotgun", as you do have to walk around a course, in beautiful surroundings, and the targets require some thought and planning, as well as some skill.

There is another variation of this sport called "5-stand". Rather than walking a full course, there are 5 stations side-by-side, and you alternate stations after 5 shots for a total of 25 targets. There are 5 or more fixed traps which throw various presentations for the shooter. Each station has a sequence of target presentations, and they are challenging, to say the least. Usually, you shoot 3 singles and a double at each station, or some other combination of the two. It is a quick way to loosen up before going around a full course; or provide some quick but challenging shooting if you are time-constrained. Also, where there isn't sufficient space at a club to have a full sporting clays course, they can usually install a 5-stand facility. As a result, this version of the game is very popular.

But most of us shooters really enjoy the full sporting clays courses where the presentations are a constant variety of targets. Most clubs specify 50 targets to go around the course for standard sporting clays, and singles and doubles are all part of the game. Many stations use both, with a pair of singles being presented, followed by a double. Club rules may vary, but generally allow using 2 shots at singles, if you so desire.

There are a couple of interesting variations of double presentations, as well. There is the "true" double, where both targets are thrown simultaneously. There is also the "report" double, where the second target is thrown at the sound of the gun firing at the first target, and the "delay" double, where the second target is thrown a second

or two after the first target. Each of these requires some getting used to - but these are conditions that all too frequently occur when shooting at wild birds. They are challenging, and it's good practice to get used to them.

Targets are varied, using "Standard" clay birds with a diameter of 108mm, "Midi" clay birds at 90mm, "Mini" clay birds at 60mm (the so-called "aspirin"), a 108mm flat and thin "Battue" target (*often referred to as the "flying razor blade" when viewed from the edge*), and a standard-sized 108mm "Rabbit" target, which is thrown on the ground, which is thick, heavy, more difficult to break, and bounces around a lot in its presentation! And, based upon their size and construction, for example, minis leave the trap faster than a standard target, but slow down faster. All the different types of targets share this aspect.

A few words to help shooting: The "minis" have about the same area as the body of a dove. Remember that, and it will help you break them. On the "Battue", wait for them to turn over on their side, presenting a full area, easy-to-break target. On the rabbits, try to catch them in a high bounce, and then they won't zig upwards when you zag on their roll



**A 5-stand sporting clays range. Shot sequence is generally three singles and a double. After each 5 shots, the shooter changes stations so the angles are constantly changing.**

line. The rest of the targets are pretty straightforward.

You can get experience at just about any type of target and shot, and it makes good practice to improve our shooting. But, many clubs specialize in offering "Hunter Clays", with targets more typical of game birds and bunnies in the immediate area, and many guys use their hunting gear when shooting, while the club also retains a "Tournament Clays" set-up for shooters who like a "technical" challenge. Both types are very popular.

This is an excellent game for the field shooter, the guy who likes a challenge, and is the fastest growing aspect of our sport! Providing good practice for the hunter, I love it! Don't expect too many very high scores; perfect scores are rare as passenger pigeons. But your overall shooting ability will improve.

Okay - but what type of load do we use for this sport, where we can expect to shoot at just beyond the muzzle to 40 yards out??? Well, let's first realize that we can change chokes. Not while standing on the station, but you can ask to "see the targets", and the trapper will oblige. So, if you want to put in a tighter or looser choke, do so before stepping up to the station. Most shooters tend to keep choke changing to a minimum, using Skeet or IC chokes for most of their shooting, and having a Modified choke tube in their pocket for an extremely long shot. They rely on changing loads to serve the purpose, rather than choke changes. I also know shooters—one a former State Champion—who carries only one load - a 2-3/4 dram equivalent, one-ounce loading of hard 8s at 1200 fps (*but he always carried a few trap "super handicap" loads in a pocket for the very long targets*).

What I use is a light 7/8-ounce loading of either 8s or 8-1/2s for targets less than 25 yards, and a heavier 1-ounce loading of 7-1/2s or 8s for shots over 20 yards. Yes, there is some overlap, but I don't worry about it. I carry a box of each in different pockets of my shooting jacket (*color-coded as I previously mentioned*). But for tough hard-to-break rabbits at longer ranges (30 yards and beyond), or for dif-

ficult very long-range targets, I have a few heavy "Handicap" trap loads in the vest pocket of my shooting vest just for insurance. Yes, I could carry some "spreader" loads for ultra-close ranging targets, but I don't feel I need that much "insurance".

The loads that I regularly use work well in my 12-gauge over/under, and follow:

#### **Inside of 25 yards**

**Case:** Winchester AA 2-3/4" 12-gauge shell  
(red-colored case)

**Primer:** Win. 209

**Powder:** 16.5 gr. Red Dot

**Wad:** WAAL (gray)

**Shot:** 7/8 oz. chilled 8s or 8-1/2s

**Vel:** 1200 fps

**Press:** 7,900 psi

**Source:** *Alliant Powder Reloaders' Guide*

#### **Beyond 20 yards**

**Case:** Winchester AA 2-3/4" 12 gauge shell  
(gray colored case)

**Primer:** Win 209

**Powder:** 19.5 gr. Green Dot

**Wad:** WAASL (pink)

**Shot:** 1 oz. hard 7-1/2s or 8s

**Vel:** 1200 fps

**Press:** 8,500 psi

**Source:** *Alliant Powder Reloaders' Guide*

#### **Long-Range Rabbits, etc.**

**Case:** Remington 2 3/4" Premier 12-gauge shell

**Primer:** Win. 209

**Powder:** 20.0 gr. Green Dot

**Wad:** Rem RXP12

**Shot:** 1-1/8 oz. hard 7-1/2

**Vel:** 1250 fps

**Press:** 9,400 psi

**Source:** *Alliant Powder Reloaders' Guide*

Now that I am comfortable in this relatively new sport, I'm starting to use a 20-gauge gun for this game. I'm starting to develop newer loads for effectiveness on these targets, and it's fun experimenting. I've got a couple of promising loads, but haven't finished my evaluations. But both 3/4-oz. and 7/8-oz. loads seem to work pretty well, and give good patterns.

And I have a Remington 1100 autoloader that is a 28-gauge Sporting Clays model with Briley extended choke tubes. Hmmm - with target loads of 3/4-ounce of shot, at 1200 fps, it patterns beautifully out to 35 yards by just changing choke tubes. With mild recoil, and lighter weight of gun and shells... why not use it! I guess that's my next major fun project!

And that's the lure of reloading for the clay games. You get to shoot more, have fun, reduce costs, and meet some very nice people. You become a better shot. In addition, if you use care, and are fussy, you can make up loads tailored for your gun that are fully the equal of (*and maybe even better than*) factory loadings!

Do reloads  
improve shotgun  
performance over  
factory loads?

# Buy 'Em or Stuff 'Em?

By JOHN HAVILAND

**THE ANSWER TO** the title question is yes and no. In general, handloading shotshells for your special shooting needs and for less popular gauges does indeed upgrade the effectiveness of your shotgun and save you a bundle of money over the cost of factory shells. However, if you're duplicating a particular factory load, reloads won't elevate the performance of your shotgun and in some cases may not save you any money.

### **Saving Money and Tailoring Loads**

Last year my wife decided to go along on the annual pheasant hunt. Pheasants require a hard hit to knock them dead, so a fairly stout load was required for her 20-gauge. I stopped by the local sporting goods store to check on 20-gauge pheasant loads and was shocked at the price. High velocity (1220 to 1300 fps) 2-3/4" 1- and 1 1/8-ounce loads of high quality hard shot cost \$9 for a box of 25. I wanted to experiment with a couple different shot weights and pellet sizes, but if I bought a box each

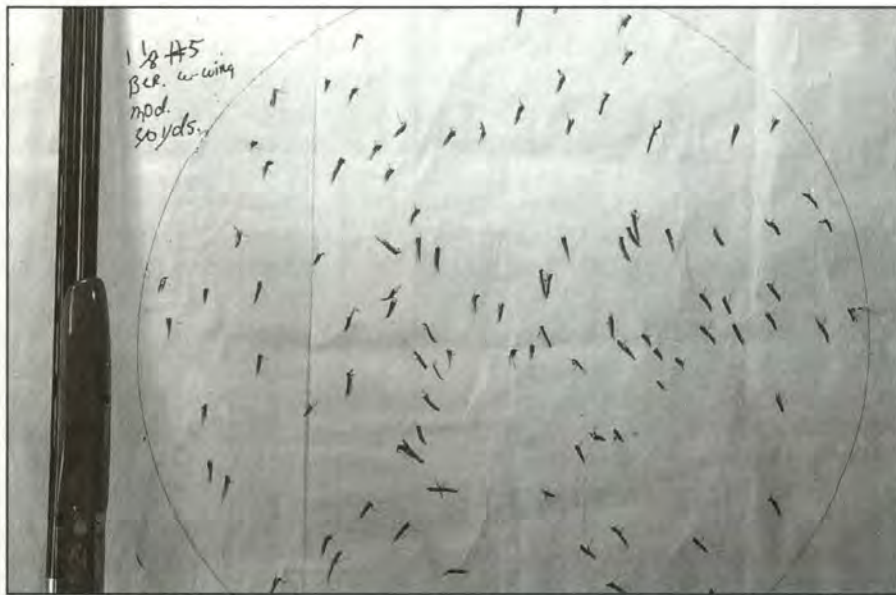

Reloading allows experimenting with different loads without the expensive of having to buy a whole box of shells.



Taking that extra step during reloading helps protect shot so it flies true.

of the factory shells I'd be out \$36 before I even started.

Instead I went home and set up my MEC 650 reloader. I loaded six Remington 20-gauge shells each with 1- and 1 1/8-ounce 6 percent antimony #5 and #6 shot and different Winchester powder charges for velocities of 1150 to 1200 fps. I patterned two shells each at 40 yards through my wife's Beretta over/under with Modified and Full chokes. Here's the loads and what the Beretta shot:

Powder.Grs.	Primer	Wad	Case	Shot Wt.-#	Choke	% Pattern
W571/24.0	W209	WAA20F1	Rem.	1-5	Modified	50
"	"	"	"	"	Full	59
"	"	"	"	1-6	Modified	66
"	"	"	"	"	Full	86
W571/23.5	"	"	"	1 1/8-5	Modified	53
"	"	"	"	"	Full	64
"	"	"	"	1 1/8-6	Modified	67
"	"	"	"	"	Full	73

Right off the bat the 1 1/8-ounce loads produced too much kick for my wife to shoot in her six-pound gun, so those were eliminated. One ounce of #5 shot patterned okay, but not all that well. However, the #5s, with their high pellet energy, are a good load for hunting in the thick brush where it's imperative to knock a rooster dead, or even the best dog will not have a chance of catching up with the running bird. The real winner in the Beretta was the one ounce of #6s. The Full choke patterns with #6s were actually too tight at 40 yards, with the majority of the pellets in the center of the pattern. I screwed out the Full choke tube and replaced it with the Improved Cylinder choke and that choke shot slightly over 50 percent patterns with one ounce of #6s. The Modified patterns with #6s evenly covered the 30-inch pattern circle without a gap large enough for a butterfly to slip through.

During our pheasant trip my wife shot the one ounce of #6s load through the Modified and Improved Cylinder chokes in her gun. She killed a couple birds at 45 yards and lots between 25 and 35 yards. I figure the components for those shells cost \$3.75 a box.

Speaking of recoil, before my youngest son's first spring turkey hunt he tried a 12-gauge three-inch magnum with 1-3/4 ounces of shot.

The recoil really belted him and he immediately put the gun down and said the heck with that. I knew he would be hunting the edges of farm fields and a long shot at a gobbler was a real possibility, so he needed a load that would kill out to 40-plus yards.

If I could come up with a load that would keep nearly all its pellets on target, my son could shoot a long-range load, but with a lighter amount of shot and with much less recoil. So I set to work. I shot the outline of a turkey head and neck at 25 and 50 yards with several of my 12-gauge 2-3/4 and three-inch reloads in which I took every step to protect the shot charge, and several factory loads. The results are listed below.

The proper wad is the best way to protect shot from the slam of the powder gas and scraping down the bore. While shooting the loads listed below I recovered many fired wads. The wads showed indents from the pellets on the bottom inside of the shot cups. The impressions were much shall-



Factory turkey loads shoot tight patterns. However, taking extra steps during handloading to protect shot can put the same number of pellets on target, but with a reduced amount of shot.

lower in wads with legs that compressed on firing and cushioned the setback of the shot on firing. For example, load #6 fired a WAA12R wad with collapsible legs and placed 20 killing pellets on target at 50 yards. The same amount of shot in a plain shot cup in load #7 placed only half that many pellets on target.

Shot takes its worst beating as it grinds down the bore and squeezes through the choke. It really takes a beating if the walls of the cup are too short to entirely enclose the length of the shot column. Load #15 used a plain WAA12 wad with 1-5/8 ounces of #5s. However, the wad was really designed to shoot up to only 1-1/4 ounces of shot. At 25 yards the load piled 51 killing pellets into the head and neck of a turkey target. But at 50 yards the pellet count dropped off to 15 hits because the shot that was deformed by contact with the bore flew wild. In contrast, load #14 with 1-3/8 ounces of #5s in the WAA12R wad and further protected with a plastic wrap stuck 39 pellets in the target at 25 yards and 21 at 50 yards. (The plastic wraps I used were cut from photography transparency holders in the shape of a rectangle to fit the inside of the shot cup.) The lesser, but better protected, amount of shot provided a more effective killing pattern at long range where big gobblers peacock about.

Pellets are also damaged when they smash into each other.

Buffer, such as ground polyethylene, sifted into the shot column fills up the space between pellets and acts as a cushion to keep pellets separated. The only difference between loads 7 and 8 was the addition of buffer (and one grain less powder in #8 to compensate for the increased charge weight). The buffer upped the pellet count by nearly half at 50 yards.

However, for buffer to protect pellets it must be sifted evenly into all the spaces between the shot. A few of the factory loads and my reloads containing buffers gave dismal results, much worse than those without buffer. Cutting a portion of the shell cases away from remaining loads showed the buffer was not evenly distributed among the pellets and, in some cases, a shell contained an insufficient amount of buffer that had settled around only the top portion of the shot column. If anything, the bottom of the shot column requires the most shielding since the bottom pellets are crushed from the force of the powder gas as well as the pellets from above.

Even when the shot column is fully protected from the bore, some shot is still distorted. The heavier the charge, the longer the column and the more shot there is to scrape against the bore. From perusing the listed loads, 1-5/8 ounces of lead shot seems to be the point of diminishing returns for the 12 bore. Load #3, Winchester's XX 2 3/4-inch with 1-5/8 ounces of #5s placed 11 pellets in the turkey target at 50 yards, while load #12, Winchester's XX three-inch two-ounce load of 5s, tallied 22 hits. Those extra 11 pellets on target for the three-inch load came at the expense of firing 64 more pellets.

Here's how many pellets the Full choke of a Remington Model 870 placed in the outline of the head and neck of a turkey gobbler with six factory loads and ten handloads loaded with IMR 4756, Hodgdon HS7 and HS6 and Winchester 540 and 571 powders:

### 12 Gauge 2 3/4-Inch

#	Loads	Ounces/Shot	Vital Hits			
			25 Yds	50 Yds		
1.	Winchester Super X	1 1/4/5	34	10		
2.	Winchester XX Magnum	1 5/8/4	42	12		
3.	"	1 5/8/5	41	11		
4.	"	1 5/8/6	53	17		
			Vital Hits			
	Case	Powder/Grns.	Wad	Shot Wt.#	25 Yds	50 Yds
5.	RXP	4756/30	WW12R	1 3/8/6	48	21
6.	"	HS7/32.5	WAA12R1	1/2/5	49	20
7.	"	4756/25	BP12 & Gas Seal	1 1/2/5	31	10
8.	"	4756/24	BP12, Gas Seal & Buffer	1 1/2/5	30	16
9.	"	HS7/31	WAA12R & Buffer	1 1/2/5	39	13
10.	"	HS7/28.5	WAA12R, Wrap & Buffer	1 1/2/6	76	16





An old Winchester Model 12- in 16-gauge with a 2 9/16-inch chamber requires reloading.

Twelve-gauge reloads with one ounce of hard shot pattern well.

## 12 Gauge Three-Inch

#	Loads	Ounces/Shot	Vital Hits	
			25Yds	50Yds
11.	Winchester XX Magnum	2/4	57	16
12.	Winchester XX Magnum	2/5	56	22

#	Case	Powder/Grns.	Wad	Shot Wt.#	Vital Hits	
					25Yds	50Yds
13.	WCF	HS6/32.5	WAA12 & Buffer			
				1 3/8/5	69	12
14.	"	540/35	WAA12R Wrap			
				1 3/8/5	39	21
15.	"	571/37	WAA12			
				1 5/8/5	51	15
16.	"	571/30.5	WAA12F114 & Buffer			
				1 5/8/5	26	16

## Factory Loads

For his turkey hunt, my son selected the 2 3/4-inch load consisting of HS7 powder, WAA12R wad and 1-1/2 ounces of #5s. Recoil was still there, but reduced enough that he even practiced with a few shots. When a gobbler came to the call he killed it with one shot just short of 40 yards. Those loads cost about 18 cents apiece, compared to nearly 70 cents apiece for similar factory loaded turkey shells.

Sometimes, hunters need shotshells that quickly spread shot. These spreader loads are so specialized that ammunition companies do not even attempt to provide these loads.

Spreader loads are the only defense against heart-stuttering ruffed grouse that thunder up at your feet or incoming sporting clays that threaten to hit you in the forehead. Spreading shot for wide patterns at close range can be accomplished a variety of ways, such as loading special spreader wads, shooting soft shot, increasing velocity and using spreader inserts.

Soft, or chilled, shot is often somewhat out of round before it's even fired. The kick of the powder gas and the grating ride down the bore distorts it even more. In-

creasing the powder charge further deforms shot on firing and the additional velocity flares shot due to increased air resistance. All this results in shot that flies askew from the start and opens patterns, and that's just what we want for short-range shots.

However, out-of-round shot can produce gaps in patterns. What we're after is a shotgun pattern with controlled chaos.

I take a somewhat less expensive, yet time-consuming, route to open patterns for shooting blue grouse lurking in the aspen groves. I make spreader inserts from index cards that go in the shotcup of a regular wad. (Poster board also works well, but anything thicker takes up too much space in the shot cup.) I cut the index cards into rectangles that fit the width and height of a shotcup. The size of the cut cards depends on the volume of the shot cup. For instance, a Winchester WT12 wad accepts a rectangle 0.65-inch wide and 0.80-inch long. A Winchester WAA16 wad takes a card 0.60-inch wide and 0.88-inch long. Then I cut half way up the middle of each piece so two pieces slip together to make a + shape. The + spreader is placed in the shotcup, shot is poured evenly into the four sections and the case mouth crimped shut.

My theory is when the shot exits the barrel the spreader spins and disrupts the shot column with a lateral push. The ory or not, the spreader inserts work. The loads listed below show the spreaders increased the pattern size of a Modified choke at 20 yards up to six inches and dispersed shot clustered in a 15-inch circle by up to 34 percent.

Loads 1 and 3 compares a fiber wad with no shotcup to protect shot against the bore to a Winchester WAA16 wad with a protective shotcup. There really was not that much difference in pattern size at 20 yards between the two loads. However, adding a spreader card to the fiber wad and the WAA16 wad loads really widened pattern size.

The 12-gauge loads 7 and 9 show the extra velocity and pressure from a few grains of powder opened patterns a good four inches. Combine that hotter load with a spreader



Snipping off 16-gauge shells to 2-9/16 inches, and then loading them, gets my old Model 12 16-gauge up and shooting.

insert (available from Midway USA), or my inexpensive shot divider, and bombshell grouse will be in the bag and those incoming sporting clays you've been dodging will be blasted into harmless dust.

### Spreader Loads

#### 16 GAUGE (20 yards)

#	POWDER/GR.	WAD	OZ.-SHOT	% 15" CIRCLE	PATTERN DIA. INCHES
1	UNIVERSAL/19	Fiber	1-6	81	22
2	UNIVERSAL/19	Fiber & Spreader	1-6	50	27
3	UNIVERSAL/19	WAA16	1-6	81	21
4	UNIVERSAL/19	WAA16 & Spreader	1-6	53	25

#### 12 GAUGE (20 Yards)

#	POWDER/GR.	WAD	OZ.-SHOT	% 15" CIRCLE	PATTERN DIA. INCHES
5	WSF/27	WT12	1 1/8-6	90	15
6	WSF/27	WT12 & Spreader	1 1/8-6	64	19
7	WAAP/21	WAA12L	7/8-6	89	15
8	WAAP/21	WAA12L & Spreader	7/8-6	73	21
9	WAAP/23	WAA12L	7/8-6	83	19
10	WAAP/23	WAA12L & Spreader	7/8-6	63	24

(Universal by Hodgdon, WSF and WAAP by Winchester)

### Unpopular Gauges

If you shoot a 16-gauge, you are in a bind anymore if you rely on factory 16 gauge shells. Most full-service sporting good stores still stock a few 16-gauge loads. But if you

handload you don't have to run around town or search the Internet looking for shells. Handloading also helps the 16 reach its true potential.

One ounce of 6 or 7-1/2 shot is a great load in the 16 for Huns, grouse and sharptails. But add loads of 1-1/8 or even 1-1/4 ounces of #4 or #5 shot and the 16 a true all-around upland gun for birds up to the size of sage hens. The following are some great loads for the 16 that are as near as your reloader: (Remington Model 870 Improved Cylinder choke)

#### 16 GAUGE (30 Yards)

POWDER/GR.	PRIMER	WAD	CASE	SHOT/WEIGHT	PATTERN %
WSF/20.5	W209	WAA16	WCF	7 1/2/1 1/8	64
UN/17	W209	2-.135"			
		Cards			
		+ 1-.375"			
		Fiber Wad	WCF	7 1/2/1	58
UN/21	W209	WAA16	WCF	7 1/2/1	78
UNI/19	W209	WAA16	WCF	7 1/2/1	71

#### (40 Yards)

HS6/24.5	W209	WAA16	WCF	6/11/8	64
571/30	W209	SP16	WCF	6/11/4	75

#### Full Choke (40 Yards)

4756/21	W209	SP16	REM.	6/1 1/4	91
4756/21	W209	SP16	REM.	4/1 1/4	86
4756/22	W209	SP16	REM.	6/1 1/8	85
UN/21	W209	SP16	REM.	7 1/2/1 1/8	79
RD/16	W209	SP16	REM.	7 1/2/1	81

Pattern circles proportionally reduced from the standard 30-inch circle at 40 yards: 22.5 inches at 30 yards. WSF-Winchester Super Field; UN-Unique; UNI-Universal; RD-Red Dot.

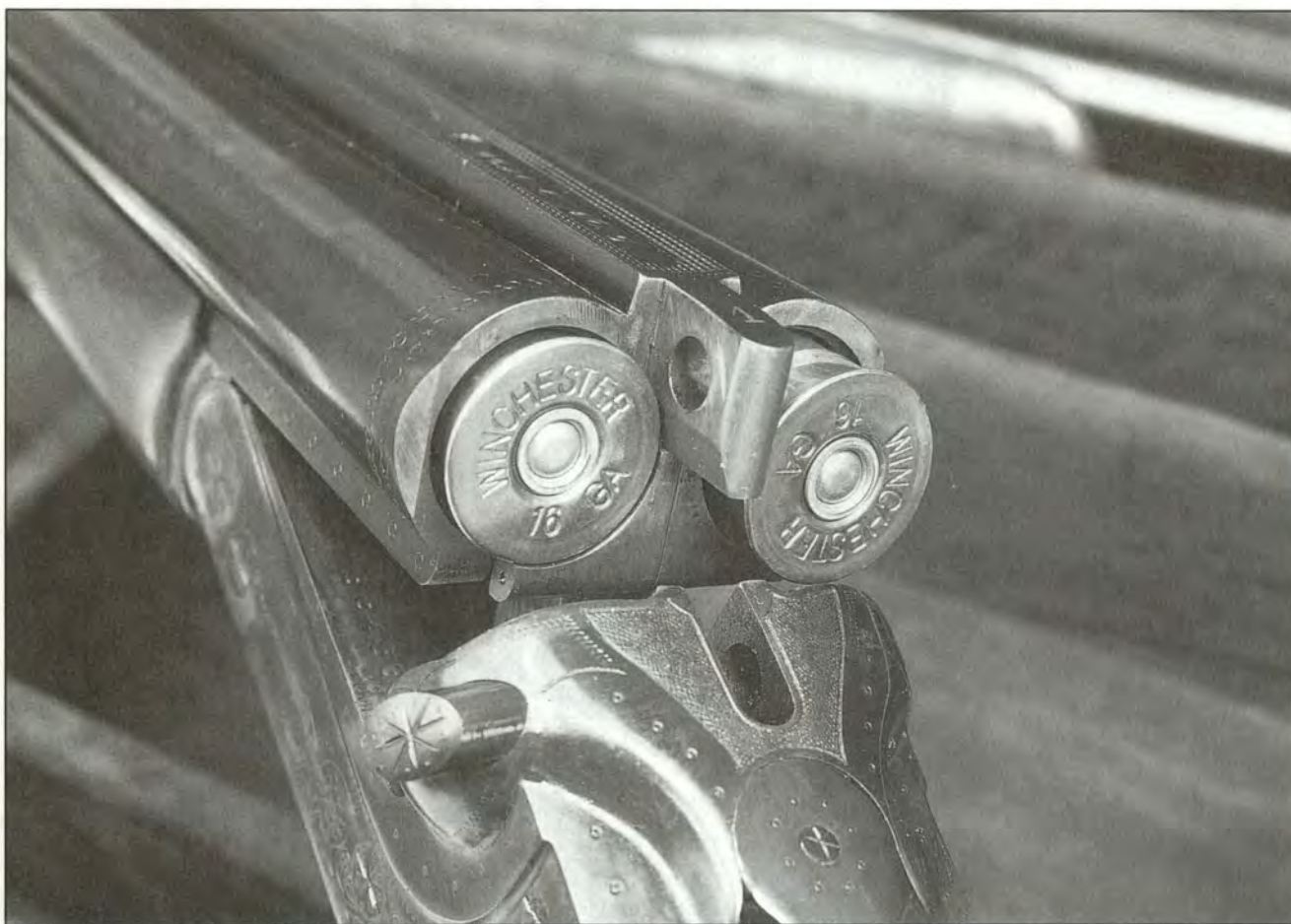

Reloading really helps the performance of less popular gauges.

### What Handloading Doesn't Improve

On the shelves at the local mega-stores sit Federal, PMC, Remington, Winchester and other brands of 20- and 12-gauge shells with a price tag of \$3 for a box of 25. These shells are loaded with 3/4-ounce of shot in 20-gauge and 7/8-ounce in 12-gauge of #9, #8 or #7-1/2 shot. The shot is soft or "chilled" shot, wads usually consist of a fiber gas seal and spacer with maybe a plastic wrap around the shot column and hulls that are usually nonreloadable. Velocities are about 1150 feet per second (fps). Patterns with these shells are often a bit sketchy past 30 yards. Still, they are an incredible bargain. Powder, primers, wads, shot and hulls alone cost more than these loaded shells.

So I buy lots of them. A lot of other people do too. A powder manufacturer told me these inexpensive shells have significantly reduced handloading among shotgun shooters. I use these shells for informal clay target shooting and close-range dove and ruffed grouse hunting. My wife especially likes the low recoil of the 20-gauge load for practicing with her lightweight Beretta Whitewing. She uses the 3/4-ounce of #7-1/2s in her 20-gauge and does quite well with them on grouse.

Nontoxic waterfowl loads are another case where handloads fail to improve on factory loads, and in many instances handloads are inferior.

Recently, on the shelf at the local store, Federal, Remington and Winchester steel loads with 1-1/4 ounces of steel #2s were priced at slightly more than \$8 for a box of 25. These shells also had the nice touch of a waterproofed crimp. To duplicate a box of those shells with handloads the components ordered mail order cost \$9.25, and that doesn't include postage. And handloaders will probably have

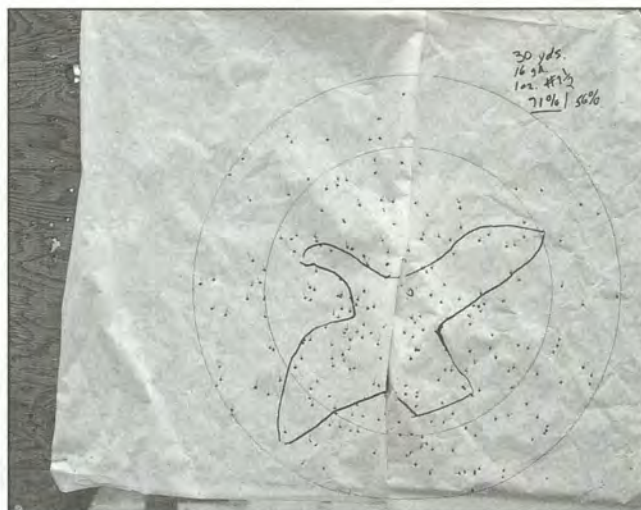

Pattern with one ounce of shot from the Model 12 16-gauge with a 2 9/16-inch chamber.



Factory shells that cost about \$3 a box are hard to beat.

to order nontoxic shots and wads through the mail as very few sporting good stores stock these unpopular items.

These great prices on steel shells are the result of fierce competition among ammunition manufacturers. A spokesman for Federal remarked competition in the steel shotshell business is "dog eat dog."

Handloading steel shot has really not kept up with factory steel loads. The relatively light weight of steel shot requires high pellet speed to kill ducks and geese. Various commercial loads reach nearly 1600 fps with 1-1/8 ounces

of steel. What little reloading data is available pretty much limits handloads to about 1300 fps. Alliant Powder's Steel powder is about the only powder that currently matches the velocities of factory-loaded steel shotshells.

Nor will a handloader save money or improve ballistics by handloading other nontoxic shots like bismuth or Hevi-Shot. Midway USA sells seven pounds of bismuth for \$92.36 and seven pounds of Hevi-Shot for \$84.05, not including shipping. That works out to well over a dollar just for 1-1/4 ounces of these shots. Loaded shells from Bismuth Cartridge and Remington cost from \$1.50 to \$2.00 apiece.

In addition, ammunition companies have put a lot of research into developing great-patterning loads with steel and other nontoxic

shots. I commonly receive 70 to 90 percent patterns at 40 yards with these nontoxic shots.

In the end, shotgunners should realize handloading is a hobby. The labor put into tailoring shotshells to meet your needs can't be counted as an expense. On the contrary, it's time well spent because it relaxes the mind and keeps us out of places where we'd spend much more money, like bars and malls. We always want to shoot the best shells possible, and there's no rule that states handloaded shotshells are always the best. Sometimes, the best shells come from the factory.

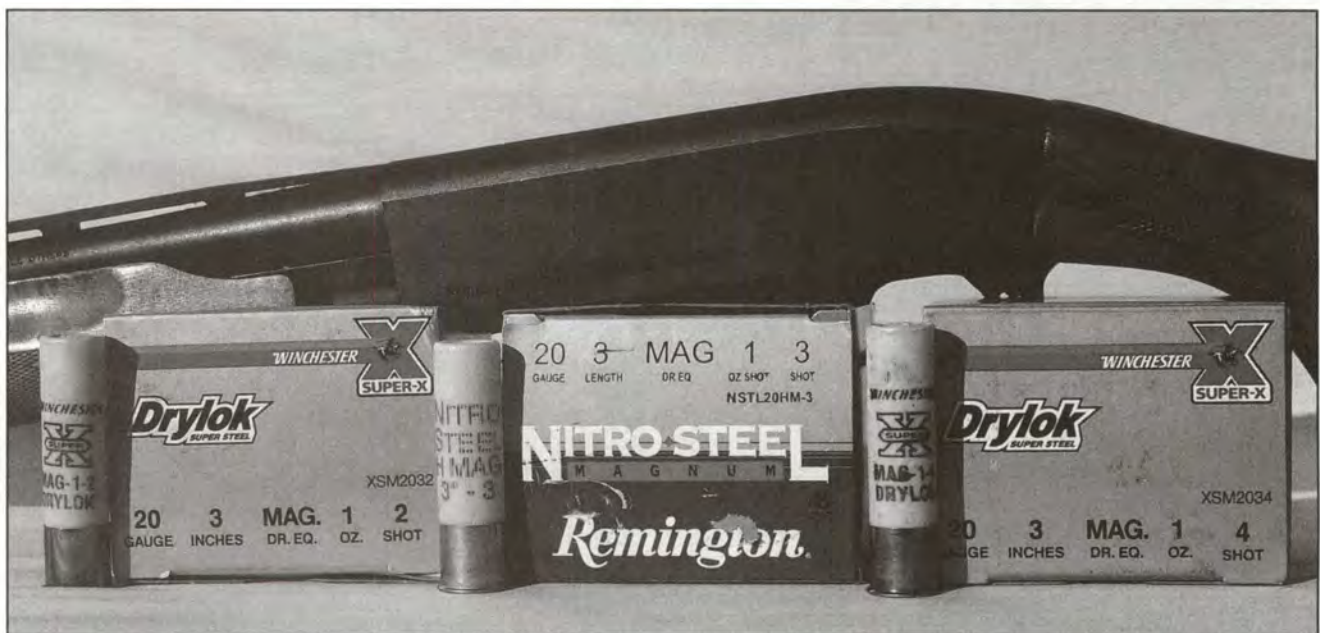

In the author's opinion, factory-loaded steel shot loads for waterfowl are cheaper and perform better than handloads.

Progressive presses let you shoot more and spend less time at the reloading bench.

# Fast Track Reloading

By JOHN HAVILAND

**I USED TO** sit in the basement on Saturday mornings looking out the window at the blue sky, stuck in the dark because if I wanted to shoot the following week I had to reload rifle, handgun and shotgun shells, one at a time. Then I bought a progressive press to reload rifle and handgun cartridges and another progressive press to load shotshells. Suddenly my weekends were free. What used to take all day Saturday to reload was done on the progressive presses in one weekday evening.

With dozens of progressive presses on the market, reloaders can choose a press that's just right for the amount of reloading they need to do. A casual shotgun shooter may want to choose a manual-indexing MEC 650 that loads a few hundred shotshells an hour. But a serious handgun shooter who practices several times a week knocking over steel plates and running the shooting courses may require the 800 rounds an hour production of a Dillon XL 650. All of these progressive presses are very versatile machines.



The popular MEC 650 shotshell reloader.

### Versatility

My first progressive press for metallic cartridges was an RCBS Ammomaster. All I had to do was insert a fired case in the first station and a bullet on the primed and charged cases before each pull of the press handle. I religiously watched each station as a primer was seated, powder dropped and a bullet seated. At the back of my mind, though, I worried that a case might not receive a full powder charge, or perhaps a double charge of powder. Pretty soon I was peering into each case to make sure they held the correct amount of powder. That severely reduced my production. Finally, I added a Lock-Out Die to the press between the powder charging and bullet seating stations. The Lock-Out Die allowed the press to cycle when a case contained the correct amount of powder. But if a case received no powder or a double charge of powder, the Lock-Out Die bound up and halted the press ram from rising. The Lock-Out Die gave me some peace of mind and I smiled when a loaded shell dropped into the ammo catch bin.

After using the press for awhile I found it also worked well as a partial progressive press, performing only one or a couple of loading steps at a time, and much more quickly than a

single stage press. This is an advantage when the cases need extra preparation to produce quality loaded cartridges.

For example, after a few firings the grime on handgun cases and residue in primer pockets require cleaning. So I disconnect the primer and powder dispensing systems and screw out the bullet seating die. I feed the cases into the press, sizing them, knocking out the primers and expanding the case mouths. The time required to do these two steps takes about a fifth of the time it would on a single-stage press because I only have to feed the cases through the press once, instead of twice with a single-stage press, and the cases eject automatically. All the sized cases go into my tumbler for a bath.

With the handgun cases bright and shiny I remove the sizing and depriming dies from the press, then screw in the bullet-seating die and reattach the primer and powder systems. Then the clean cases are fed into the press for final loading. Out come the loaded cartridges, shiny as a new penny.

With rifle cases I like to clean the lubrication from the cases and residue from the primer pockets each time they are resized and also make sure the cases are trimmed to the correct length. To do that, the rifle sizing die is screwed into the first station on the press and all the cases are fed through the press. The cases are then cleaned and trimmed to the proper length.

With the rifle cases ready to load I remove the sizing die from the press and screw in the bullet-seating die and reconnect the primer and powder measurer systems. (Some picky reloaders seat primers by hand ahead of time for that extra touch of consistency.) The shells are fed through the press for priming, powder charging and bullet seating. The clean, trimmed and loaded shells kick out of the press ready to shoot.

The final loading of rifle cartridges is quick if the powder has a flake or spherical shape. These powder forms measure uniformly through a volume measurer because the grains pack closely together. Charges of powders such as flake-shaped or ball-shaped propellants vary only a couple tenths of a grain in weight dumped from a measurer.

However, the weight of many tubular-shaped powders can vary quite a bit when dumped from a measurer on a progressive press. I have detected weight variations of up to two grains with some measurers with tubular-shaped powders. This is a concern for the hunter shooting maximum loads or the long-range target shooter who needs consistent velocities.

When using these types of powder I remove the powder measurer and mount it on my bench at the side of the press. I dispense a slightly lighter charge of powder than needed from the measurer and then weigh it on a scale, dribbling the last few grains in with a powder trickler to bring the charge up to the intended weight. With the ram of the press up, I pour the powder through a funnel into the waiting case. After lowering the operating handle a bullet is inserted in the mouth of the charged case, the handle raised again to rotate the case around and up into the bullet die.



**The Dillon RL 550 B loads more than 120 different rifle and pistol cartridges.**

This system of full progressive, partial, or single-step reloading makes a progressive press a versatile machine indeed. Anymore the only use I can think of for my slow old single-stage press is to prop open the front door during the heat of summer.

Here's a review of the current progressive presses on the market:

### **Dillon Precision**

Dillon's Square Deal B was designed to produce large amounts of ammunition for a little bit of money. The Square Deal B comes complete with a factory-adjusted carbide die set, ready to load the pistol calibers of your choice at a rate of 400 to 500 rounds per hour. All you need to do is set the automatic powder measure and select the bullet seating depth. A Square Deal B caliber conversion kit enables changing from one caliber to another in minutes.

Dillon's AT (Advanced Turret) 500 press can be used to perform one loading step at a time. With the addition of auto prime, powder and loaded round eject systems, the AT 500 can be upgraded to a RL 550B progressive press.

Dillon says more RL 550Bs have been sold than any other

progressive machine in the world. It loads over 120 different rifle and pistol calibers and its quick-change toolhead allows changing calibers without having to readjust dies. Used with Dillon three-die pistol sets, the RL 550B allows crimping separately in the last station. This feature makes die adjustment easier and produces a more consistent and accurate round of ammunition. The RL 550 has optional accessories like a Low Powder Sensor, Plastic Roller Handle, Strong Mount and Bullet Tray.

The XL 650 loads virtually every popular pistol and rifle cartridge utilizing standard dies at a rate of 800 to 1000 rounds per hour. The optional powder charge check die on the third station sounds an alarm if the powder charge in a round is incorrect. A new primer system design uses a rotary indexing plate that controls each primer and keeps a steel shield between the primers and the operator at all times. Optional accessories include an Electric Casefeeder, Powdercheck System, Low Powder Sensor, Roller Handle, Strong Mount and Bullet Tray.

The Super 1050 features a lengthened frame and a new crank assembly that provides an increased stroke to accom-

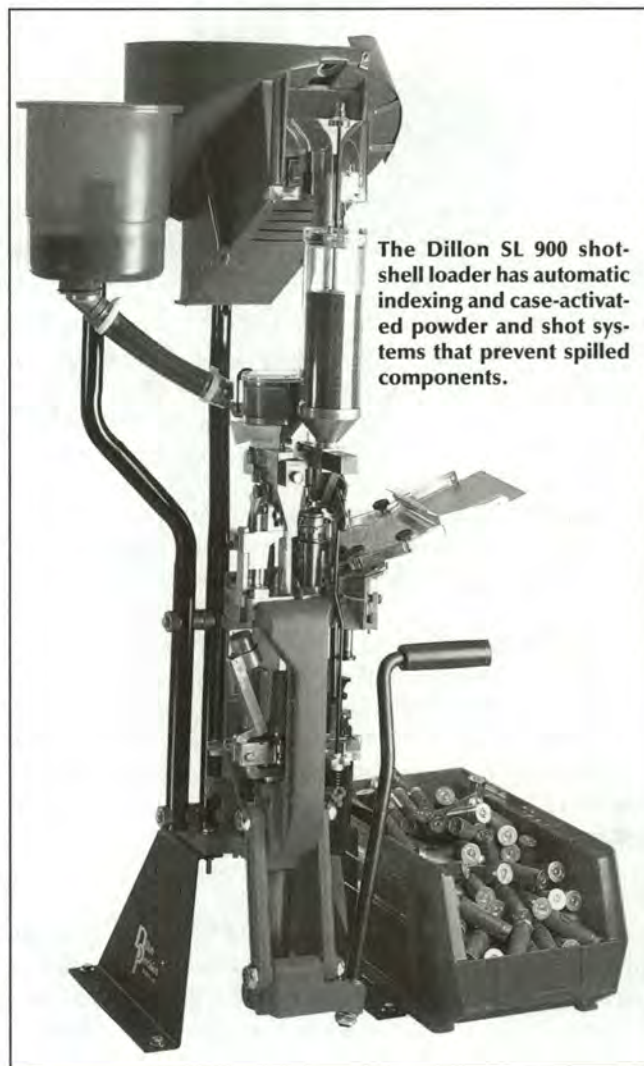

**The Dillon SL 900 shot-shell loader has automatic indexing and case-activated powder and shot systems that prevent spilled components.**



**Hornady 366 Auto with full-length resizing and automatic primer feed.**

moderate cartridges from the 9mm Luger to the 30-06. The 1050's new frame and crank assemblies have been improved to provide greater strength and smoother operation. The Super 1050 is warranted for life from defects in materials or workmanship, plus a one-year, 100-percent warranty against normal wear.

Dillon's SL 900 shotshell loader features automatic indexing and case-activated powder and shot systems that eliminate spilled powder and shot. An electric case collator automatically inserts cases. Adjustable shot and powder bars do away with fixed-volume bushings. With an adjustable shot bar, the right weight of shot drops, no matter if 9s or 4s. Switching from loading one gauge to another is easy, because an interchangeable toolhead holds all the dies and slides in and out of the frame. The SL 900 is available in 12-, 20- and 28-gauge and features an automatic casefeed system.

### **Hornady**

The 366 Auto shotshell loader features full-length resizing, automatic primer feed, swing-out wad guide, three-stage Taper-Loc crimping, automatic shell advance and ejection. Additional die sets are available in 12-, 20- and 28-gauge.



**Hornady Lock-N-Load AP with case feeder.**

The Lock-N-Load Automatic Progressive (AP) reloading press features the Lock-N-Load bushing system that enables you to change dies with the flick of the wrist. The AP includes automatic indexing, easy removal or replacement of a case at any station, primer tube on/off switch and a case activated powder drop.

### **Lee Precision**

Lee has always been known for its value-priced reloading equipment. Where else can you buy a fully automatic press for two pennies less than \$200? The Lee Pro1000 loads handgun cartridges and rifle cartridges up to the length of the 223 Remington. Cartridges can be loaded one at a time, or full auto. Primers and powder are fed only if a case is present in that station.

The heavy-duty Lee Load-Master comes ready to load cartridges from the 32 S&W to the 45-70. The Load-Master has automatic indexing, a quick-change shell plate to speed up caliber changes, four tube case feeder, powder measurer and primer feed.

Accessories for the Pro1000 and Load-Master include a case feeder, case collator, adjustable powder charge bar, bullet feed kit or four tube adapter for the bullet feed.



Lee Loadmaster with four-tube case feeder.



### MEC

I've loaded a ton of 20-gauge shells on the MEC 650. The press works on six shells at once and with every pull of the handle a reloaded shell is completed. However, the MEC 650 does not resize shotshells. A separate step with the MEC SuperSizer is required for that. The 650 has three crimping stations. The first starts the crimp, the second closes the crimp and the third tapers the shell. The 650 is available in 12, 16, 20, 28 and .410 bore.

The 8567 Grabber performs ten different operations at six stations to quickly produce a finished shell with every stroke of the handle. It has a fully automatic primer feed, an auto-cycle charging and three-stage crimp. The "Power Ring" resizes shells without interrupting the reloading sequence. After each pull of the handle the reloader puts in a wad and shell casing and removes a loaded shell. Kits are available to load three-inch shells and steel shot.

The 9000G and 9000H contain all the features on the 8567 Grabber, plus automatic indexing and finished-shell ejection. The Auto-Dex automatically moves the shells through each reloading stage by simply returning the handle to the top of its stroke. With the hydraulic model, the 9000H, the operator inserts the empty shells and wads, and the reloader does the rest. With each complete downstroke

of the foot pedal, all reloading operations are performed at all six stations.

### Ponsness/Warren

The new 800 Plus is equipped with a star gear, index pad and index gear. It also has a die removal cylinder, allowing for quick and easy shell removal at virtually any station. Its EZ-Fill Access Hopper holds a pound of powder and 25 pounds of shot. The 800 Plus also has a brass external-adjusting primer feed assembly and quick-changing tooling kits that install in a tool head, allowing you to convert to another gauge in under five minutes without having to readjust any of the crimping stages.

Like the 800 Plus, the Platinum 2000 series reloaders are equipped with the EZ-Fill Access Hopper. It allows you to quickly change shot and powder bushings without taking the top plate off the machine. The large, divided hopper holds over 25 pounds of shot and a pound of powder. Also standard is the External Adjusting Brass Primer Feed, which easily changes primer seating depth.

Ponsness/Warren's Hydro-Multispeed works on the 950, 900 and 800 series of presses. The system allows for hands-free reloading, has three speeds with instant start and stop and is equipped with front and back adjustments. A Mul-

Lee bullet feed kit

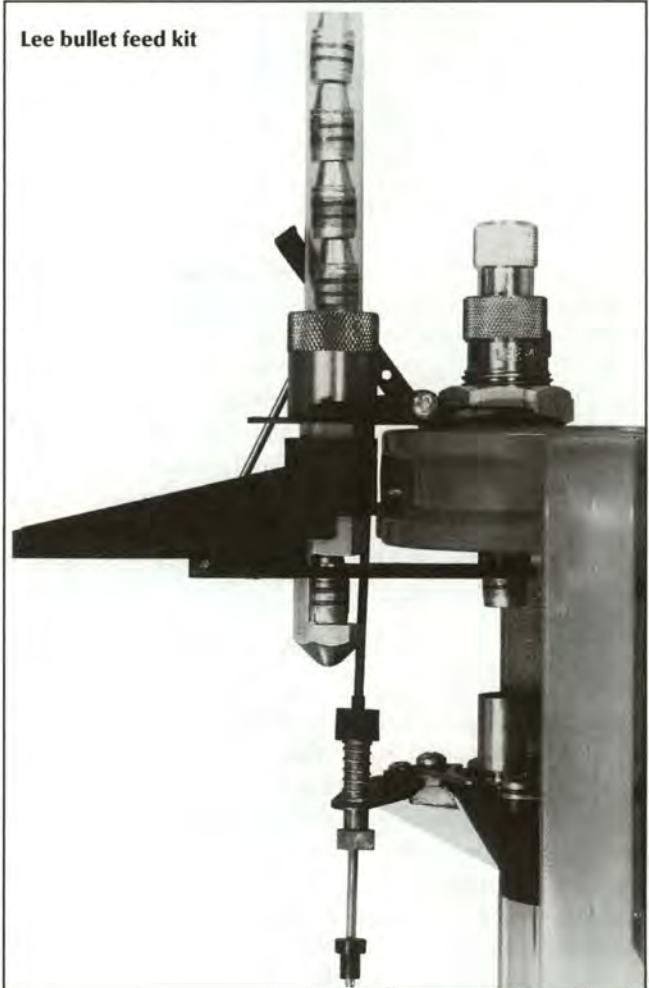



The MEC 8567 produces a finished shotshell with every stroke.

tispeed Cylinder Kit allows converting multiple Ponsness/Warren machines to hydraulics, while using the existing pump, motor and foot control valve.

The Du-O-Matic 375C costs about a third of other Ponsness/Warren progressive press. It loads hard nontoxic shot or lead shot and has an access plug for adding buffers in the shot charge. A tip-out wad guide makes an easy job of inserting wads in cases and a spring-loaded ball check centers the size die at each station. The press comes ready to load 10, 12, 16, 20, 28 or .410s in 2 1/2-inch, 2 3/4-inch, 3-inch or 3 1/2-inch shell lengths.

## RCBS

The Pro 2000 is a manual-indexing press with five stations. All the reloader has to do is keep an eye on the powder and primer supply, rotate the shell plate by hand, insert a case at the first station and a bullet on a charged case, pull the handle and watch the loaded cartridges stack up. The 2000's extra station allows the use of a powder check die or separate crimping die.

If you own an RCBS single-stage Rock Chucker, Reloader Special-3 or Reloader Special-5 press, the Piggyback III conversion unit moves you to five-station progressive reload-



RCBS APS Primer Strip loader tool loads 25 primers in a strip in just seconds.

RCBS Rock Chucker Supreme press with Piggyback 4 progressive reloader attached and ready to load 38 specials.

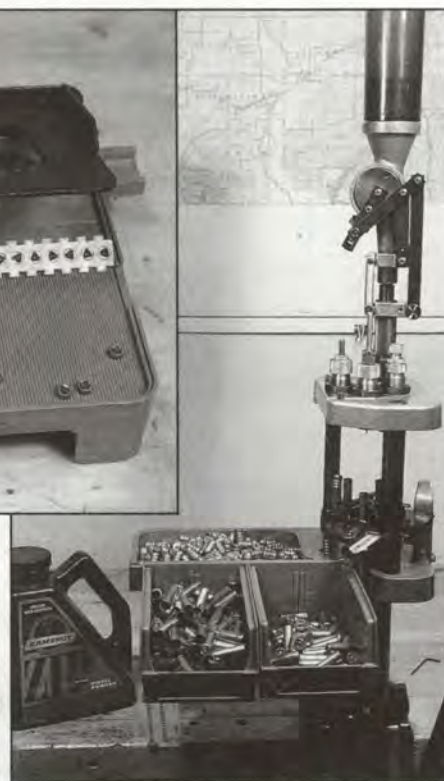

ing in one step. The Piggyback 4 unit fits the new RCBS Rock Chucker Supreme press. These Piggyback units are compact and just the ticket for reloaders who don't want to or don't have the bench space to mount and set up another press.

The Piggyback 3 reloads all pistol (except 25 Auto) and rifle calibers up to 223 Remington. The Piggyback 4 handles cartridges in length up to 30-06. Interchangeable die plates speed up caliber conversion and the APS Priming System is reliable and safe. The Universal Case Retention System allows easy removal and insertion of cases at each station.

Before I can tell you about using the Piggyback 4, I have to tell you about my old RCBS single-stage press. I bought an RCBS Junior press 30 years ago when I started hand-loading as a teenager. I have loaded at least 150,000 rounds of handgun and rifle ammunition on the press during those years. The last cartridge I loaded on the press was a 7mm Winchester Short Magnum. Bullet run-out of that cartridge was .002-inch, which shows the press ram is as tight and perfectly aligned as the day I bought it.

Recently I switched to an RCBS Rock Chucker Supreme press for its added leverage and extra length to ease loading magnum rifle cartridges. The Piggyback 4 unit screws into the top of the Supreme press and increases my output from 50 to nearly 400 cartridges per hour.

Assembling the Piggyback 4 kit, installing it on the Supreme press and figuring out how to work it smoothly took about one hour.

The Piggyback 4 uses APS primer strips to feed primers during loading and an APS Strip Loader is included in the kit. Each plastic strip holds 25 primers and the strips can be

linked together for a continuous feeding into the press. The Strip Loader works by sliding an empty strip into the tool then placing a package of primers on the grooved flat of the tool. Gently shaking the tool side to side flips all the primers anvil-side up. The tool is then tilted forward so a primer falls into each hole of the plastic strip. Tilting the tool back moves extra primers away from the strip. Pressing down on the tool handle seats the primers in the strip. Another strip is slid into place and another 25 primers are seated. After I got the hang of it, I could load 100 primers into strips in about one minute.

From there I was up and loading 38 Specials. The Piggyback held the sizing die, case mouth expander die, powder measurer, powder checker die and bullet-seating die. All I had to do was set a fired case in the first station and a bullet on the case charged with powder, pull the handle down and back up, rotate the Star Wheel to advance the cases and watch the loaded cartridges pile up in the bin. When I was finished, I unscrewed the Piggyback from the Supreme press and stored it in under my bench—where it takes up hardly any room.

I've been loading 12-gauge shotshells on RCBS's Grand press for nearly two years. Ever since then I no longer have to sweep up inadvertently spilled powder and shot because the Grand only dispenses powder and shot when a shell is present to accept it. That's just one of the Grand's features that make loading shotshells easy and fast.

The Grand comes fully assembled, except for the shot and powder hoppers and spent primer catcher. Those require only a couple minutes to install. After weighing the dispensed shot and powder to make sure they were correct, every pull of the handle kicked out a finished shell. All I had to do was insert a hull in the first station and a wad in the fourth station.

The press weighs nearly 40 pounds and its heavy frame, steel rod assembly, 1.5-inch diameter ram and compound leverage system make it sturdy and powerful enough to effortlessly load shells. Each pull of the handle completes eight reloading steps from resizing a case to ejecting a finished shell. On the down stroke, cases rotate to the next reloading step. At every station, cases are easily removed for inspection. In addition to the lockout feature that prevented a mess of spilled powder and shot, the priming system worked flawlessly and the tilt out wad guide made inserting wads fast and easy. Each station is easily adjusted by loosening a lock nut and screwing the tools up or down to accommodate different style hulls and wads that require varying amounts of pressure to seat primers and wads and crimp the shell mouths.

Changing the powder and shot bushings involved only removing a pin, sliding out the charge bar and inserting bushings. Additional lead shot and powder bushings are available from RCBS.

For an upcoming grouse hunt I loaded 100 12-gauge shells in about 20 minutes on the Grand. When I finished, I turned the powder and shot hoppers to the "empty" posi-

tions and drained the powder and shot back into their containers. Once again, no mess.

The press is available in 12- or 20-gauge. An optional conversion kit switches gauges.

## Vibra-Prime

One step that slows reloading on progressive presses is filling primer tubes. Frankford Arsenal's Vibra-Prime speeds up that process. The Vibra-Prime has a tray that orients primers and a handle with a trigger that rapidly inserts the primers in tubes. One unit works for small and large handgun and rifle primers.



RCBS Grand. Every pull of the handle kicks out another completed shell.



APS strips feed into the Piggyback 4 progressive press. Strips link together to keep the loading process going without interruption.

Reloading  
blackpowder  
cartridges for  
hunting has many  
rewards with  
plentiful guns and  
components.

# New Era for Traditional Hunting

By KENNY DURHAM

**HUNTING WITH BLACKPOWDER** cartridge rifles has become ever increasingly popular in the last few years. The abundance of reproduction single-shot and repeating rifles of the American blackpowder era combined with the historical interest in the late 1800s have fostered hunting with these rifles throughout the country. This in turn has ushered in a whole new era of handloading blackpowder cartridges. So much so that even some of the old loading tools from the late 1800s are being made once again.

At one time, all of our cartridges were loaded with nothing but blackpowder. Not until the 1890s did we see smokeless powder begin to replace blackpowder. Then, just as now, cartridges came in all shapes and sizes for hunting game of any size and demeanor. Today, we have fewer caliber selections in newly manufactured arms, but the selection is ample for hunting the smallest to largest game animals.

Many of the blackpowder cartridges made the transition from black to smokeless powder, mostly due to also having been chambered in repeating rifles. The W.C.F. (Winchester Center Fire) chamberings of 25-20, 32-20, .32-40, 38-40, 44-40, 38-55 and 45-90 are a few examples. Undoubtedly, the most famous of all blackpowder rifle cartridges is the 45-70 Government. It has been around since 1873, been chambered by virtually every rifle maker in America, and for which ammunition has been in continuous production. Because the 45-70 is the easiest to load and the cartridge most often loaded with blackpowder, we will use it as our example as to how to properly craft blackpowder hunting ammunition for use in single shot and repeating rifles.

## Reloading Components for Blackpowder Cartridges

### Brass Cartridge Cases

Brass cartridge cases are available for all the popular chamberings and many of the obsolete cartridges. For example, Winchester, Remington, and Starline all produce 44-40, 45 Colt and 45-70 brass for handloading, in addition to other original blackpowder cartridges. Additionally, Starline has added to their product line brass for 40-65 Win., 45-90, 45-100 and 50-110 Winchester, to name a few. For any given rifle, I like to have a minimum of 60 cases and preferably 100. Ideally, the cases should be from the same lot of production or at least be all from the same manufacturer.

### Bullets for Hunting

Bullet selection for blackpowder cartridges should be limited to lead alloy bullets having multiple grooves for carrying an abundance of bullet lube. Additionally, hunting bullets should be of a style such that the maximum amount of energy is transmitted to the target. Spire-pointed or sharp-radius round-nosed bullets may pass through an animal without expanding at all. Such was the case with a buffalo that I shot on a recent hunting trip. The long-range target-style bullet used in my Shiloh Sharps 45 x 2-6/10 (45-100), entered between two ribs, passed through the top of the heart, and exited the far side between two ribs. The wound was fatal, but a flat-pointed bullet would likely have produced quicker results with less chance for the wounded animal to escape. When using a lever-action repeating rifle, the flat-pointed bullets required for use in tubular magazines are also the best choices for hunting.

Excellent cast and swaged bullets, often pre-lubricated with blackpowder bullet lube, are available from several sources. Should you desire to cast your own bullets, Lyman, Redding-Hunter (SAECO),



Two of the author's favorite powerful blackpowder cartridge rifles: a 45 caliber 1874 Sharps single shot by Shiloh Rifle Manufacturing and an original 40-caliber 1886 Winchester repeating rifle.



A selection of original blackpowder cartridges (l-r) 38-55 Win., 40-82 Win, 45-70 Govt., 45-90 Win., 44-77 Rem., 45-70 Govt., 45 x 2-6/10 (45-100), 45 x 2-7/8 (45-110), 50-70 Govt.. The four on the left are loaded for repeating rifles; the five on the right are for single-shot rifles.



Brass is available for almost any obsolete blackpowder cartridge. Cases shown (l-r) are 38-55 by Winchester, 40-65 by Starline, 40-82 and 43 Spanish by Buffalo Arms, 45-70 by Remington, 45-90 by Starline, and 50-70 Govt. by Bell.



Blackpowder hunting bullets should have a flat point or large round nose with many grooves for carrying lots of lube. Shown are bullets in 38-, 40-, 45-, & 50-caliber from bullet moulds by Lyman, RCBS, SAECO, and custom mould maker Steve Brooks.



Good hunting bullets are also available from many sources. Meister Bullets offers a selection of cast bullets lubed with SPG (left & center). Buffalo Arms offers cast and swaged bullets (right).

Lee Precision, and RCBS offer a variety of bullet moulds for virtually every caliber of blackpowder cartridge. Custom bullet moulds, sometimes a requirement when loading for original rifles, are available from custom mould makers such as Paul Jones and Steve Brooks. Typically, bullets used with blackpowder have been cast from a soft alloy of lead and tin varying from 40:1 (2-percent tin) to as much as 16:1 (6-percent tin). Bullets formed from harder alloy such as the Lyman #2 formula or wheel weights can perform well with blackpowder if the rifle barrel is in good condition and without pitting.

Lubricated bullets are the most common style available and by far the easiest to use. However, should we choose to take an additional step back to the late 1800s, paper-patched bullets and moulds are available from several sources. Much of the factory-loaded hunting and target ammunition for blackpowder cartridge rifles in the late 1800s was loaded with paper-patched bullets. On our buffalo hunt, my partner Bill Richins took his buffalo with a Shiloh Sharps 45 x 2-4/10 (45-90) loaded with a paper-patched bullet of his own making.

#### Bullet Lube for Blackpowder Bullets

The hard lubes that we use for modern smokeless powder lead bullet loads in rifles and handguns do not work when used with blackpowder. With blackpowder, the sooty resi-



A good bullet lube, formulated to work with blackpowder is a must. Some excellent lubes are available from Ox Yoke, Lyman, Sagebrush Products, SPG and DGL.

due or fouling deposited in the bore with each shot, throws another consideration into the mix. A hard bullet lube may prevent leading but will do nothing towards moderating the fouling. To accomplish this, a soft lube, formulated with waxes and oils from non-petroleum products works the best. The soft lube works by coating the bore as the bullet passes through, leaving a thin film upon which the fouling is deposited. Subsequent shots will push out the fouling from the previous shot and deposit a fresh film of lube.

The original Sharps formula consisted solely of sperm whale oil and bees wax. Today, many good lubes are available such as SPG, Lyman Blackpowder Gold, Rooster Red, Sagebrush Alox, and DGL. If you want to make your own homemade lube, a very simple and excellent blackpowder lube can be made using equal parts beeswax and olive oil. The cheapest yellow beeswax and cheapest olive oil are all that are needed, and are also the best.

#### Primer Selection

Any primer suitable for smokeless powder will also work with blackpowder. My preference is to use magnum primers to insure good ignition of the powder charge. In 45-caliber rifle cases, I use Federal 215 magnum primers almost exclusively with Goex and Swiss blackpowder. In 44-40 and 45 Colt I use CCI 350 large pistol magnum primers. With Swiss powder, in my 40-65 and 38-55 rifles, Remington 9-1/2 standard and magnum primers have produced very accurate loads. Benchrest or match primers are not required for hunting ammunition.

#### Blackpowder & Blackpowder Substitutes

Not that long ago, the available selection of blackpowder was limited to only a couple of choices. But thanks to the renewed interest in shooting blackpowder firearms from all periods of history, the selection of powder available to us is more than adequate for any need. We are fortunate to have sporting and military grades of blackpowder, of which I am



In the 21<sup>st</sup> century, excellent blackpowder is more plentiful and available in more grades than we have seen in decades.



Hodgdon produces Pyrodex and Triple Seven—propellants suitable for use in blackpowder cartridge rifles.



45-70 Govt. case loaded with 60 grains of Goex Cartridge and a fiber wad atop the charge. The thin card wad protects the bullet base but may not be necessary for hunting loads.

convinced, are some of the highest quality black-powder ever produced. Loading data is also available from each powder maker pertinent to their specific granulations. In addition to the selection of blackpowder, there are now several substitute or replica powders on the market. Hodgdon's Pyrodex and Triple Seven are two examples. Pyrodex has been around for a couple of decades now, but Triple Seven is only a couple years old. Both are fine products that work well in blackpowder cartridge firearms. I have tested and used both products with good results. That said, my personal preference is to use blackpowder for most all of my shooting. Whether using blackpowder or a blackpowder replacement, follow the manufacturer's recommendations of loading procedures and loading data.

### Over-Powder Wads

The use of a thin card or plastic wad of 0.030" (1/32") up to 0.060" (1/16") between the powder charge and the base of the bullet is strictly optional. The wad serves to protect the base of the bullet from the hot gasses. Target shooters typically use wads in their ammunition, myself included, and accuracy is improved. Hunting ammunition will usually perform well enough without the use of a wad. If you choose to use a wad, they are available for any caliber, pre-cut from vegetable fiber, gasket material, or poly plastic. Wads can additionally be made from thin cardboard, milk cartons, or plastic coffee can lids. Wads are not needed when using copper gas checks.

### Putting it All Together

#### Case Preparation - Sizing

Whether our brass is new, or once-fired factory ammunition, the initial step is to full-length size the cases. The sizing die should be adjusted to touch the shell holder so that the case will enter the die as far as possible. With the die screwed in to the correct depth, but with the locking ring loose, run a case fully into the die and leave it there. Next, tighten the lock ring to secure the die. By tightening the die in this manner our sizing die will be aligned with the loading ram and having all of the slack taken out of the threads. The primer can also be inserted during the sizing process if this is your preferred method of reloading. I usually seat the primers in a separate operation.

#### Expanding the Case Neck

Once the cases are sized and primed, the next step is to expand the case mouth to accept a lead bullet. Extend the loading press ram to its full height and thread the neck-expanding die into the press,

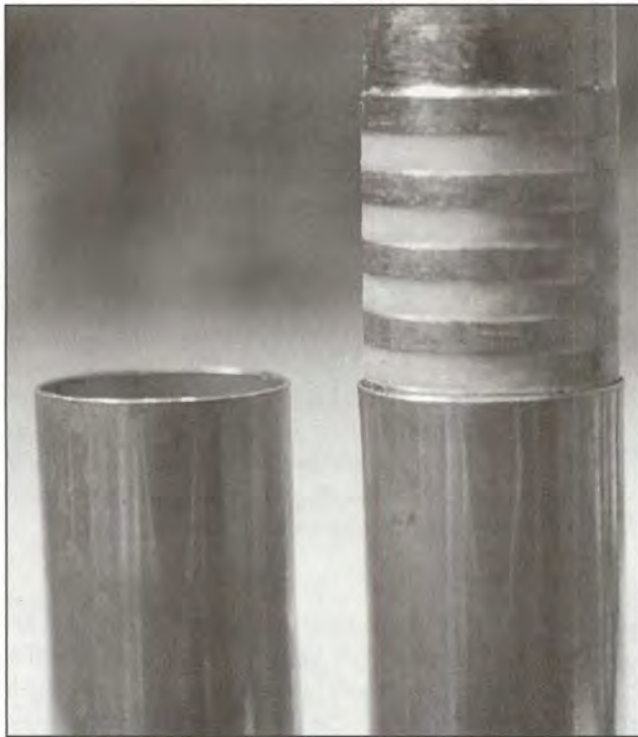

Case neck should be expanded to the full depth to which the bullet will be seated. The mouth (*before-left*) needs only to be belled enough to accept the bullet for seating (*after-right*).

stopping just short of the shell holder. Next, back the expander plug out enough to insure that we will not turn our case into a miniature brass trumpet by over-belling the mouth. Then, through successive trial and error, incrementally adjust the expander plug so the case mouth is expanded just enough to allow a bullet to start into the case. With the die properly adjusted, lock all of the adjustments down with a case in the die for best alignment.

One thing with which to be aware is that most expander plugs are designed for use with jacketed bullets and are therefore 0.002"- 0.003" smaller than the nominal groove diameter for a given caliber. For example, an expander plug for a 45-70 die may measure 0455"- 0456", which is fine for use with jacketed bullets. Additionally, the length of the expander may be shorter than the shank of the bullet. In other words, the expander plug may not expand the case mouth to the full depth of the seated bullet. The result is that soft bullets can be inadvertently sized when seating the bullet. One might think that the brass would stretch and give way to the mass of the bullet, but not so. The diameter of the bullet will actually be reduced. The solution is to acquire a custom expander plug for your die of the correct size and length for about \$20. For hunting loads, we should be OK. But, if the accuracy is not up to par, this is one area of the loading process to check.



Powder measures for metering blackpowder, Lyman 55 Blackpowder Measure (*left*) complete with drop tube (not seen) and a vintage Belding & Mull Visible Powder Measure (*right*).



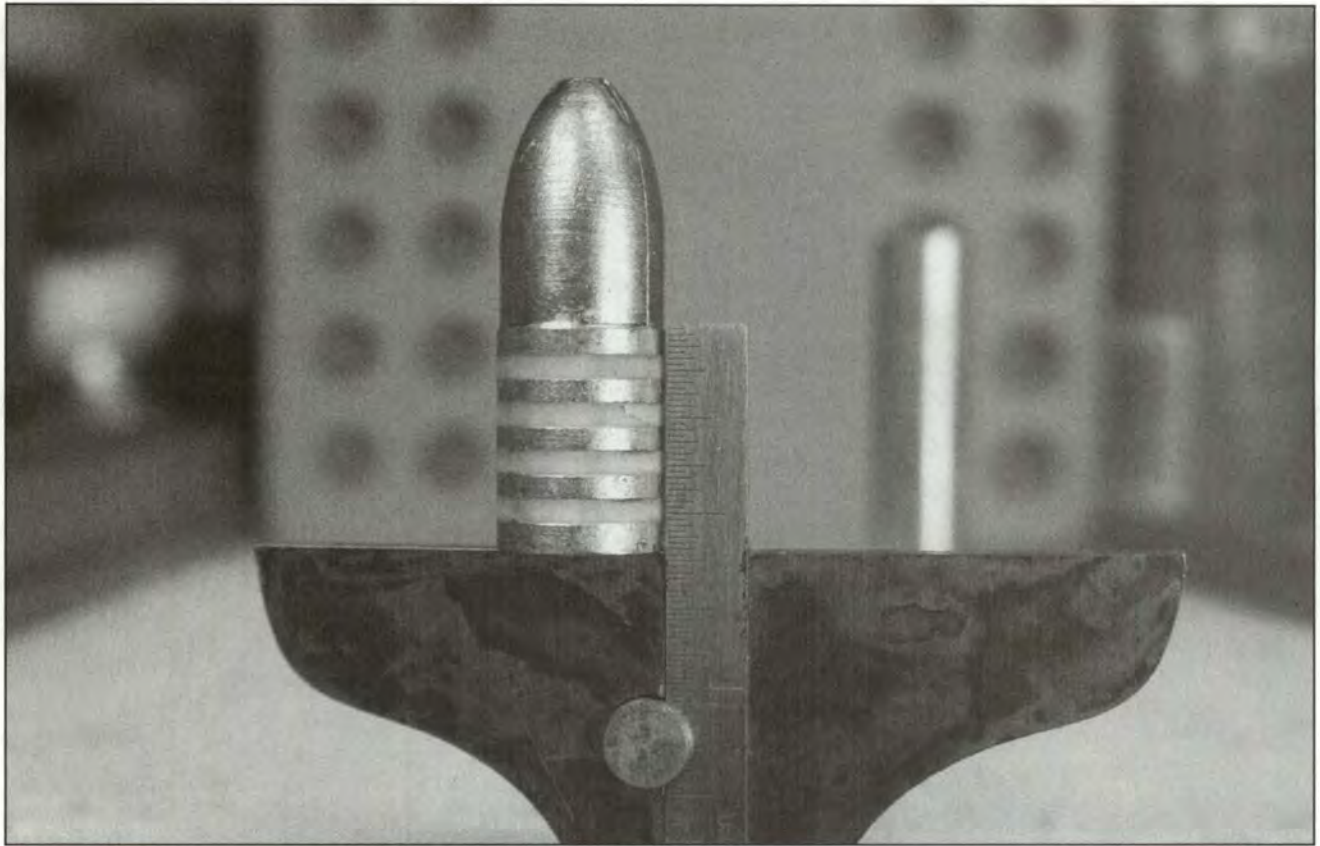

The first step in determining the powder charge is to determine the depth to which the bullet will be seated. In our 45-70 example, the bullet will be seated fully, with the case mouth crimped over the front driving band.

### Arriving at the Correct Powder Charge

Once we have determined our choice of brand and the proper granulation of blackpowder for the cartridge to be loaded, we can then determine how much powder to use.

**Question:** How DO we know how much blackpowder to use?

**Answer:** All that the case will hold. But, read on.

In our smokeless powder mind set, where 1/2-grain of powder can make a big difference, it sounds cavalier that we would determine our powder charge in such a seemingly inexact method. But, not so, here is where we take our departure from the methods used in smokeless powder reloading.

When loading cartridges with smokeless powder, we determine the charge by carefully weighing the powder, giving little concern to the volume that it occupies. The weight is the critical factor.

With blackpowder, the exact opposite is true. When loading cartridges with blackpowder, we determine the charge by the volume of space to be occupied by the powder, giving little concern to its weight.

The reason for this is that the actual weight of the powder charge may vary several grains depending upon the brand and lot number of the blackpowder being used. For example, the original 45-70 Govt. load using a 405-grain bullet required a powder charge of 68 to 72 grains of blackpowder to give the desired velocity of 1350 fps.



45-70 with the bullet seated approximately half-way to the final depth.

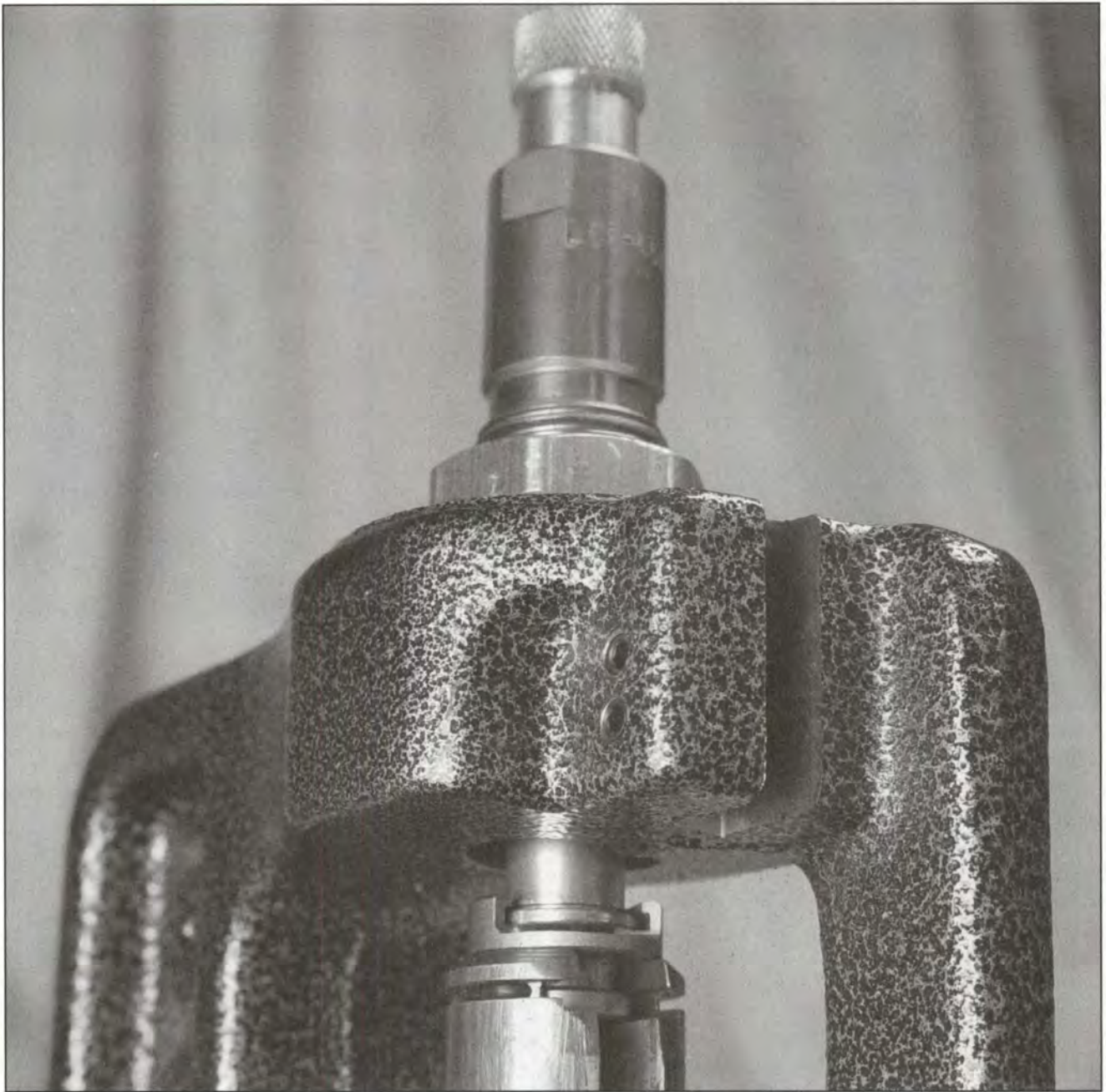

**Bullet seating die adjusted so that no crimping of the case mouth will occur during the bullet seating. Crimping will be in a separate operation.**

Cartridges of the blackpowder era were designed to use the full capacity of the case to contain the charge of blackpowder and the bullet. The powder charge filled the entire case up to the base of the bullet. Take a 45-70 for example; regardless of the length of the bullet, be it a short 300-grain bullet or a long 550-grain bullet, the case was filled to capacity with blackpowder. The actual charge for the 300-grainer might require a charge of 75 or more grains of powder while the powder charge for the 550-grainer might be only 65 grains or less. Our hunting loads should be loaded in the same manner.

To determine how much powder to use, we must first determine the depth to which our bullet will be seated, or

more simply put, the maximum overall length (OAL) of the loaded cartridge. In a single-shot rifle, this length can vary a lot depending upon the bullet choice. In repeating rifles, the length of the action is the limiting factor. Most often, bullets designed for the specific cartridge will have a crimping groove that will properly limit the OAL. Bullets lacking a specific crimping groove should be crimped over the front driving band. With a single-shot rifle, a good way to determine the maximum OAL is to load a dummy cartridge by progressively seating a bullet deeper in an empty, unprimed case until the action will close with the dummy round in the chamber.

With the bullet seating depth determined, place a nomi-



Bullet seated with one lube groove exposed. Some single-shot rifles have a long enough throat to allow a bullet to be seated out a bit, thus allowing more powder capacity. The bullet for our example will be fully seated in the case.



Bullet fully seated to the predetermined depth and ready for crimping in a separate operation.

nal charge of blackpowder in a primed case. Using a depth gauge, which can be as simple as a piece of wooden dowel, measure the distance from the top of the powder charge to the mouth of the case. Next, compare this measurement to the desired seating depth of the bullet. If the measured length exceeds the seating depth, simply add more powder to bring the charge up to the base of the bullet. Conversely, if the measurement is shorter than the seating depth, remove powder from case. By doing this a few times we can determine, by volume, how much powder to use. For the best ignition and combustion, the powder charge should be slightly compressed. This can be accomplished when seating the bullet but only if the compression is barely perceptible, otherwise the soft bullet will be deformed to where the cartridge will not chamber. If more than just a slight amount of compression is desired, then a special compression die is used in a separate operation prior to seating the bullet. Usually, the powder can be compressed about 0.030" before bullet deformation occurs.

By arriving at the powder charge as described above, you will likely find that the actual weight of the charge is very close to the recommended loading data listed by the powder

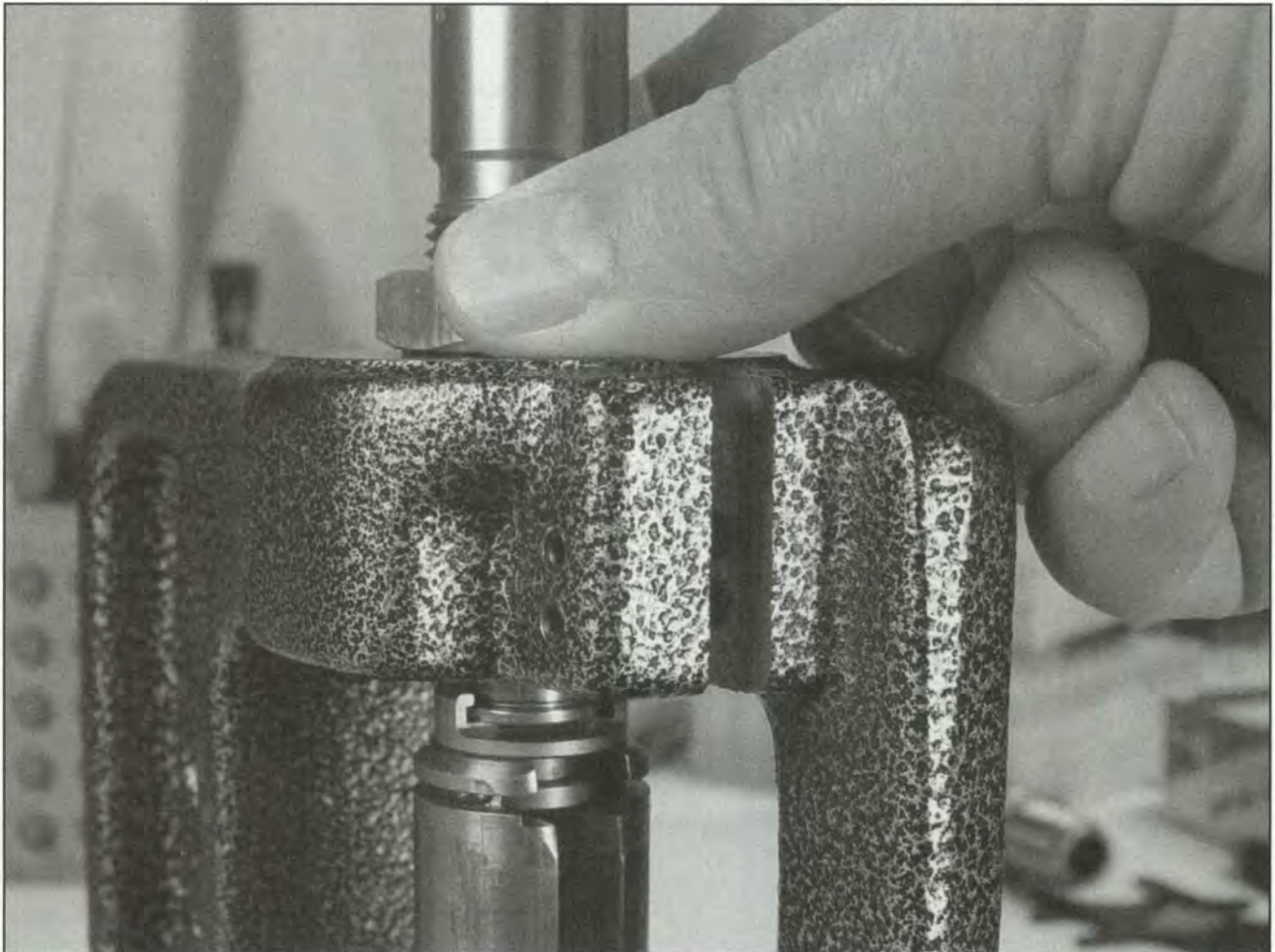

With our bullet seated to the proper depth, the die is locked down with a cartridge in the die, ensuring proper alignment. The same procedure should be used for all die adjustments.



Finished blackpowder loads having varying degrees of crimp: (l-r) light, moderate, heavy, and none. Of the two 45-70 rounds on the right, the left one is our test example having the case mouth crimped over the front driving band. The one on the right utilizes the same bullet seated shallower with a heavier powder charge, and not crimped.

manufacturer for a specific cartridge and bullet weight. In the case of our test load, the charge by actual weight totaled 60 grains of Goex FFG powder. However, the same volume of Swiss 1-1/2 Fg weighs 66 grains.

### Charging the Cases

There are several powder measures on the market specifically designed for use with blackpowder. The Hornady Blackpowder Measure, Lyman 55 Blackpowder Measure, and Belding & Mull are just three examples. Whether using a hopper style or a simple muzzle-loading style measure, use a powder measure that is specifically designed for blackpowder. One of the best ways to get the powder charge into the case is to drop the measured charge through a brass or aluminum tube 24 to 30 inches long. The Lyman 55 Blackpowder Measure includes a 24-inch aluminum drop tube. The drop-tube method compacts the powder from the base up as it fills the case. It also allows us to get more powder in the same volume due to being more densely packed. I use a drop tube for all of my rifle-length cartridges (38-55, 40-65, 45-70 etc.), but not when loading short rifle (44-40) or pistol (45 Colt) cartridges. If desired, a wad can be added atop the powder charge.

**CAUTION...Powder measures for smokeless powder are not made from non-sparking materials and therefore should not be used with blackpowder.**

### Seating the Bullets

Seating the bullets in blackpowder cartridges is a two-step process. Attempting to seat and crimp the bullet in a single operation can deform the bullet enough to affect the accuracy. Begin by threading the seating die into the press, stopping short so there is no possibility of crimping the case mouth, and back the seating stem out enough to where the bullet will be partially seated only. Next, seat a bullet into a charged case, then check to see how close we are to our desired seating depth. Hopefully, our bullet is about halfway-seated. Now, turn the seating stem in a turn or two and seat the bullet deeper. With the cartridge in the seating die, tighten the locking ring on the die body to secure the die in place. By incrementally adjusting the seating stem, continue seating the bullet deeper in the case until the desired depth is reached. Finally, with the loaded cartridge still in the die, tighten the locking ring or nut on the seating stem to secure it in place. Our seating die is now

properly adjusted to seat our bullets. Begin seating the bullets carefully and slowly, so that you can feel how each bullet enters the case mouth and slides to the top of the powder charge. Each bullet should feel the same as the one before, easy and smooth.

Cartridges for single-shot rifles do not necessarily need to be crimped. However, a slight crimp may add to uniform neck tension, and result in better accuracy. Bullets for lever actions and handguns should always be crimped. To begin the crimping operation, loosen the seating stem and back it out several turns—or completely remove it from the die. Next, loosen the locking ring on the die body and turn the die 1/4-turn farther into the press. Run a loaded cartridge into the die and check to see if any crimp has started to form on the case mouth. Repeat the process by turning the die in 1/4-turn increments until the desired amount of crimp is achieved. The amount of crimp, light or heavy, should not bite into the bullet. Once there, as before, tighten the locking the ring on the die body. Crimp the remaining cartridges, proceeding slowly and methodically to insure that each loaded round is uniform.

By following these steps and procedures, we can easily load blackpowder hunting ammunition that will be accurate, clean-burning, historically correct, and for sure put meat on the table.

*See ya at the range.*

Shotguns are the most popular, but rifle hunting for turkeys is more like big-game hunting.

# Rifle Loads For Turkeys

By STEVE GASH

**TURKEYS ARE UNQUESTIONABLY** the “big game” of bird-dom. Legions of enthusiastic nimrods pursue the wily birds with shotguns, but there is more than one way to render Big Bird onto a plate. Sure, shotguns are the most popular type of firearm but some states allow the use of a rifle -- check with your state’s fish and game agency. In these states, there are enough turkeys and terrain to go around, and you can scout for deer or elk hunting spots at the same time. In fact, rifle hunting for turkeys is a lot like big-game hunting. You walk, look, and listen.

One can take several approaches to the development of turkey loads. The most common leitmotif is to use a 22-caliber center-fire cartridge, and load a full-metal-jacket (FMJ) bullet to a low velocity. This works well, but is far from the exclusive answer. Bigger big-game rifles are also quite suitable, and specialty loads can be crafted for them, as well. The loads discussed below are summarized in **Table 1.0**



The prize – two gobblers strut their stuff in the spring.



A flock of Wyoming turkeys loitering in the Powder River Basin, 1980.

The oldest of the extant 22s, the fine little 22 Hornet is about perfect with about any 40- to 50-grain bullet that your gun will shoot. My favorite Hornet turkey load is the 40-grain Sierra HP over 12.0 grains of Winchester 296 that produces a velocity 2920 fps. This bullet, designed to hold together at very high velocities, punches a neat 22-caliber hole through a turkey, and damages very little meat. It is highly recommended. If your gun doesn't like this load,



The author with a Wyoming gobbler taken with a Valmet Model 412 combination gun. Bottom barrel: 222 Remington. Load: 55-grain Speer FMJ, 1981.

I have a couple of others for you. Check out the 45-grain Hornady SP over 11.0 grains of H-4227. Velocity is 2660 fps, and accuracy is top drawer. Another winner is the 50-grain Sierra SP and 10.7 grains of H-4227 for 2503 fps. Each of these bullets is tough enough to take a turkey with little damage if the hit is right. All of these Hornet loads were tested in a Ruger M-77/22VHZ with a 24-inch barrel. At the risk of being deported to the salt mines, I should relate that factory loads in the Hornet also work nicely for turkeys.

Probably the most popular 22-caliber centerfire is the omnipresent 223 Remington. It's far from my favorite cartridge, but rifles are readily available, and components are plentiful and cheap.

The ideal hit on a turkey is through the wing-butts. This is a small target, so you have to have good accuracy. The distance at which your gun and load can reliably hit a 2-inch target should be considered the maximum range. The most commonly used 223 bullet is the 55-grain military-type FMJ-BT. While handy, they have not exhibited the accuracy in my rifles required for turkey hunting. This "military-style" bullet is offered by Speer, Hornady, and others. Try them in your rifle, and if they deliver, cluck on. But there are better choices, and not all are FMJs, either.

In the 223, most of the 55- to 60-grain bullets loaded to 1600 to 2100 fps should be okay. Speer lists reduced loads for the 223 and all of its 22-caliber bullets except the 62-grain match and 70-grain semi-spitzer. They all use the same



The old: a treasured Savage M-219 22 Hornet.

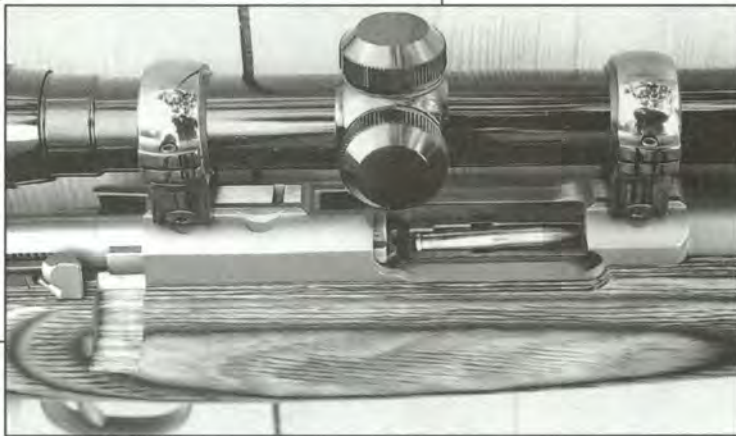

The new: a Ruger M-77/22 Hornet, with 40-grain Sierra load ready to go.

powder charge: 11.0 grains of XMP-5744, and the velocities produced are: 45-grain SP, 1949 fps; 50-grain SP or HP, 1905 fps; 52-grain HP, 1899 fps; and various 55-grain bullets, 1905 fps.

If you have to go to a higher velocity load to get the required accuracy, do it. With these bullets, there will be little meat damage if the hit is right. Apparently, speed is not a bad thing, since Hornady starts its reduced loads at 2100 fps. In the 223, this is achieved with their 55-grain FMJ-BT and 11.3-grain of SR-4759.

But the 223 is far from the only—or best—22 for turkeys. Other cartridges in the 222 family are eminently suitable, including the great 222 Remington, its larger brother, the 222 Remington Magnum, and the fantastic little 221 Fireball.

My 221 is a Remington M-700 in 222 Remington that I had rebarreled to 221 with a 22-inch PAC-NOR match stainless barrel, and it shoots so well it's scary. I have tried many loads in it, but quickly settled on one load for everything: 17.9 grains of Re-7 and the 45-grain Hornady SP bullet. Velocity is 2816 fps. My back-up load is the 50-grain Hornady SP over 17.5 grains of H-4198 at a velocity of 2809.

Another great turkey load utilizes my all-time favorite 22 centerfire, the 222 Remington. In my M-700 Remington, the 50-grain Sierra SP and 8.8 grains of SR-4759 produces a mere 1760 fps, but it is a true one-holer. The FMJ-BT set should try Hornady's load of 11.8 grains of SR-4759 for 2100 fps.

A member of the 222 family that has never resided at my house is the 222 Remington Magnum, but as you would guess, loads similar to the 222 and 223 are easy to concoct. An easy solution is to dump in 8.5 to 9.0 grains of SR-4759 over a 45- to 55-grain bullet and check for accuracy. Velocities run from 1607 to 1694 fps.

The larger centerfire 22s are not to be ignored, either. For years, I have used a Ruger M-77R in 220 Swift with



Big dogs can run in the turkey woods, too. Left, a 9.3x62 Mauser; right, the venerable 375 H&H Magnum.

reduced loads for turkey hunting, and it works so well that I have renamed it my "220 Slow." Best overall is a load of 12.0 grains of H-4227 and the 50-grain Sierra SP at 1850 fps. More than one gobbler has gone to that great platter in the sky when whacked with this load, and meat damage is very minimal. Another top performer is the Speer 55-grain FMJ (#1045) with the same 12.0-grain charge of SR-4759 for 1911 fps.

The 22-250 Remington fits in here, too. The Speer Manual shows a load of 11.0 grains of SR-4759 with a 55-grain spitzer SP bullet that gives a velocity of 1688 fps. Try a FMJ-BTs if you must, but just remember the accuracy criterion.

Another viable approach is the 70-grain Speer SS bullet. According to Speer, this bullet is designed "for large varmints up to the size of coyotes..." so it should be tough enough to be effective on the large birds. In the 22-250, 13.0 grains of SR-4759 pushes this bullet to 1711 fps. In the 220

Roll-your-own turkey loads can be easily crafted for the 22 Hornet (left), 222 Remington (center), and the 220 Swift (right) with 40- and 50-grain Sierra bullets.



Another viable option is the FMJ bullet, here the 55-grain Speer with the 218 Bee and 223 Remington.

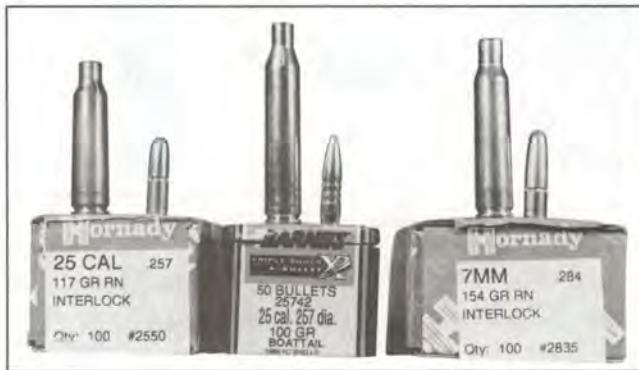

A trio of mid-bores (from left): the great 250 Savage and 117-grain Hornady RN; 25-06 with 100-grain Barnes Triple Shock X-Bullet; 7x57mm Mauser over the Hornady 154-grain RN.

Swift, 12.0 grains of the same powder gives 1642 fps. Be sure to ascertain that this long bullet stabilizes in the 1:14- and 1:16-inch twists common in these two calibers, and is accurate at these velocities. Another 22-caliber possibility is the new Nosler 60-grain Partition bullet. I have not tested them yet, but I see no reason why 11 to 13 grains of SR-4759 in either caliber wouldn't make the grade; that's where I'm going to start testing.

Lastly, a 22 bullet that begs to be tried on turkeys is the 45-grain Barnes solid. This little number is a sharp-pointed

spitzer and, like all Barnes solids, is a homogeneous alloy of copper and zinc. Barnes literature says it "does not disintegrate or deflect when it hits bone...."

### The 24s and 25s

The very popular 243 Winchester and the equally effective 6mm Remington are naturals for turkeys. With either, one can use the "slow, tough, game bullet" approach, or try a specialty load with an FMJ bullet.

For the 243, Speer lists the same charge of 17.0 grains of IMR-4198 with either their 85-grain SP (1796 fps) or 90-grain SP (1766 fps). Hornady makes a 80-grain FMJ, and starts it off at 2100 fps with 16.8 grains of SR-4759. This bullet has plenty of mass for longer ranges, and was accurate in a 6mm Remington I once had.

A bullet I have never tried at reduced velocities, but think would be a bird bagger, is Speer's big 105-grain RN. They must think so too, since they list reduced loads for it. With 18.0 grains of IMR-4198, it trundles along at a leisurely 1752 fps. If your gun will stabilize it, it would be worth a try.

The 6mm Remington, the Hornady 80-grain FMJ, and 19.4 grains of SR-4759 produce the now-familiar 2100 fps. With the 90-grain Speer SP, 17.0 grains of IMR-4198 gives a velocity of 1770 fps. Again, softpoints can be employed to good use. Following the super-heavyweight theme, the aforementioned Speer 105-grain RN can also be propelled at 1725 fps by 18.0 grains of IMR-4198.

Most of the intermediate-sized 25- to 28-calibers can be pressed into service. For example, Speer offers reduced loads for their 87-, 100-, and 120-grain bullets in the 25-06 Remington. The 100-grain Speer SP moves out along at a sedate 1524 fps when pushed by 15.0 grains of SR-4759. Reduced-power loads in the great old 7x57mm Mauser also can be effective. Again, Speer comes through with a nice load of 18.0 grains of SR-4759 and the 145-grain SP at 1517 fps.

### The Medium Bores

A similar approach can be utilized with larger calibers. Thick-jacketed bullets made for heavy game expand little when they meet light resistance at low velocities. Remember the woodchuck you hosed last deer season with your 30-06 and a 180-grain factory load? The same principle applies to a 20-lb. turkey. If you have a caliber not listed in the load table, grab your copy of the Speer Manual, and check out your cartridge. Speer lists dozens of reduced loads for almost every cartridge. In the 30- and 35-calibers, Speer's suggested loads for their heavier bullets zip along in the 1500 to 1900 fps range. As always, check to see if these (relatively) long bullets are accurate in your gun at reduced velocities.

With 150-grain bullets in the 30-06, Speer lists a charge of 26.0 grains of Accurate Arms' XMR-5744 for a velocity of 1933 fps. The round-nose, FMJ-BT, or the flat-pointed "Mag-Tip" bullets look promising. With the even tougher 180-grain bullets, Speer uses 26.0 grains of IMR-4198 for a





Traditional big game calibers and bullets can be quite effective as turkey getters (from left) 270 Winchester with 150-grain Speer Hot-Cor SP, 7mm Remington Magnum and Barnes 140-grain Triple Shock X-Bullet, and 30-06 and Hornady 170-grain FP 30-30 bullet.

velocity of 1723 fps. Again, the RN or Mag-Tip designs should work well.

The 110-grain FMJ-RN bullet intended for the 30 Carbine might be suitable, too. With the same 26.0-grain charge of SR-4759, the velocity is 1956 fps. There should be no expansion with this bullet, but at this velocity, it might be more destructive than desired. The 150- and 180-grain bullets are probably better choices.

### Big Bore Cartridges

Snicker if you must, but hear me out. Most of us would agree that a slow-moving, large-caliber pistol bullet would be okay for turkeys, so why not a similar-sized rifle bullet at a similar velocity? A couple of examples illustrate this.

for expansion at very low velocity to make sure they will expand at extreme range. He said that they use a velocity of about 1500 fps, and at that speed, an X Bullet should expand only about 10 percent. Ty forwarded some 25- and 7mm-caliber TS-X bullets for testing, and I worked up some interesting turkey loads with them.

In the 25-06, the 100-grain TS-X bullet did very well. With a charge of 15.0-grain of SR-4759 or XMR-5744, velocities were 1556 and 1459 fps, respectively, and both loads averaged a flat inch. With the 7x57mm Mauser, the 140-grain TS-X bullet over 18.0 grains of either powder zipped along at 1583 fps (SR-4759) and 1449 fps (XMR-5744). I also tried 21.0 grains of H-4198 at 1593 fps. Accuracy of these three loads at 50-yards averaged .66-inch, with the XMR-

The grand old 375 H&H is a natural. I have used 41.0 grains of SR-4759 and the 200-grain Sierra FP at 2285 fps on deer. While designed for the 375 Winchester, I'd guess that it would be fine for turkeys. Another sleeper in the big-bore category is the 9.3x62mm Mauser, and I tested three loads in it; more on them later.

### The X-Files

In a recent conversation on rifle loads for turkeys with Ty Herring of Barnes Bullets, he suggested that I try their new "Triple-Shock" X-Bullet (TS-X), which at first was puzzling. Ty explained that they routinely test X Bullets

Not to be overlooked is the fine old 9.3x62mm Mauser, shown here with Penny's 135-grain cast RB (left), and Norma's 232-grain Oryx Bonded Core bullet (right).



### Table 1. Rifle Loads For Turkeys

Cartridge	Rifle	Barrel Length (in.)	Case	Primer	Bullet Weight, Brand & Type	Powder Number	Powder Charge (grs.)	Vel. (fps)	Source
22 Hornet	Ruger M-77/22VHZ	24	Win.	Rem. 7 1/2	40-gr. Sierra HP	W-296	12.0	2920	author's load
				Rem. 6 1/2	45-gr. Hor. SP	H-4227	11.0	2597	author's load
221 Fireball	Remington M-700	22	Rem.	Rem. 6 1/2	45-gr. Hor. SP	Re-7	17.9	2781	author's load
					50-gr. Hor. SP	H-4198	17.5	2809	
222 Remington	Ruger M-77 Mk-II	22	Rem.	CCI-400	55-gr. Speer FMJ-BT	SR-4759	8.0	1662	Speer No. 13
	Remington M-700	24		Rem. 6 1/2	55-gr. Speer FMJ		8.8	1768	author's load
		20		Rem. 7 1/2	55-gr. Hor. FMJ-BT		11.8	2100	Hornady No. 4
223 Remington	Ruger M-77 Mk-II	22	IMI	CCI-400	50-gr. Speer SP	XMP-5744	11.0	1905	Speer No. 13
					55-gr. Speer FMJ-BT		11.0	1885	Speer No. 13
	Remington M-700	24	Hor.	Rem. 7 1/2	55-gr. Hor. FMJ-BT	SR-4759	11.3	2100	Hornady No. 4
222 Rem. Magnum	SAKO	23.75	Rem.	CCI-400	50-gr. Speer SP	SR-4759	9.0	1690	Speer No. 13
					55-gr. Speer FMJ-BT		9.0	1694	Speer No. 13
22-250 Remington	Remington M-700	24	Rem.	CCI-200	50-gr. Speer SP	SR-4759	10.0	1650	Speer No. 13
					55-gr. Speer FMJ-BT		11.0	1688	Speer No. 13
			Hor.	Fed-210	55-gr. Hor. FMJ-BT	IMR-4227	13.9	2100	Hornady No. 4
220 Swift	Ruger M-77R	24	Win.	Fed-210M	50-gr. Sierra SP	H-4227	12.0	1825	author's load
					50-gr. Rem. FMJ	SR-4759	12.0	1697	author's load
						H-4227	12.0	1869	author's load
					55-gr. Hor. FMF-BT		12.0	1862	author's load
						SR-4759	13.0	2023	author's load
					55-gr. Speer FMJ	H-4227	12.0	1911	author's load
						SR-4759	12.0	1956	author's load
	Ruger M-77V	26		CCI-200	50-gr. Speer SP		11.0	1669	Speer No. 13
243 Winchester	Winchester M-70	22	Hor.	Fed-210	80-gr. Hor. FMJ	SR-4759	16.8	2100	Hornady No. 3
	Ruger M-77 Mk-II		Win.	CCI-200	90-gr. Speer SP	IMR-4198	17.0	1766	Speer No. 13
	Ruger M-77				105-gr. Speer RN		18.0	1752	Speer No. 11
6mm Remington	Remington M-700	22	Rem.	Rem. 9 1/2	80-gr. Hor. FMJ	SR-4759	19.4	2100	Hornady No. 3
				CCI-200	90-gr. Speer SP	IMR-4198	17.0	1770	Speer No. 13
			Win.		105-gr. Speer RN		18.0	1725	Speer No. 11
25-06 Remington	Browning A-Bolt	22	Win.	Fed-210	100-gr. Barnes TS-X	SR-4759	15.0	1556	author's load
						XMR-5744	15.0	1459	author's load
						H-4895	24.0	1884	author's load
	Remington M-700	24		CCI-200	100-gr. Speer SP	SR-4759	15.0	1524	Speer No. 13
270 Winchester	Ruger M-77 Mk-II	22	Win.	CCI-200	130-gr. Speer SP	SR-4759	20.0	1651	Speer No. 13
7x57mm Mauser	Interarms Mark X	20	Win.	WLR	140-gr. Barnes TS-	XSR-4759	18.0	1583	author's load
						XMR-5744	18.0	1449	author's load
						IMR-4198	21.0	1593	author's load
						H-4895	22.5	1523	author's load
	Ruger M-77	22	Rem.	CCI-2001	45-gr. Speer SP	SR-4759	18.0	1517	Speer No. 13
30-06 Springfield	Remington M-700	22	Win.	CCI-200	150-gr. Speer SP	XMR-5744	26.0	1933	Speer No. 13
					180-gr. Speer SP	IMR-4198	26.0	1723	Speer No. 13
9.3x62mm Mauser	CZ 550 American	23.6	Rem.	Rem. 9 1/2	232-gr. Norma Oryx	XMR-5744	24.0	1353	author's load
						SR-4759	24.0	1483	author's load
						H-4895	34.2	1470	author's load
375 H&H Magnum	Remington M-700	24	Rem.	WLR	200-gr. Sierra FP	SR-4759	41.0	2285	author's load
	Winchester M-70	25	Win.		220-gr. Hornady FP	H-4227	35.6	2100	Hornady No. 4

Notes: The above loads were safe in the rifles tested, but may not be in yours. Do not reproduce these loads; increase only to the maxima published in the referenced loading manuals. Until you gain experience with the reduced loads, be certain that every bullet has exited the barrel. Be especially careful to avoid double charges.

5744 load grouping into a delightful .32-inch. You owe it to yourself to try these bullets. And as everyone knows, X bullets at higher velocities are no slouch on big game, either.

### Oryx Tracks

My CZ 550 in 9.3x62mm Mauser is one of my favorite big-game rifles, and it likes Norma's tough, bonded-core "Oryx" bullet. I surmised that it might make a good turkey load, but little did I know how good! With 24.0 grains of SR-4759 and XMR-5744, groups averaged .31- and .40-inch (see photos). Velocities were 1353 and 1483 fps, respectively. To say that I was pleased would be an understatement. The Oryx is also a great big game bullet.

### The 60 Percent Solution

An article in the 2004 edition of Hodgdon's "Annual Manual" has an interesting description of what Hodgdon calls their "60% rule." For any cartridge in the Hodgdon manual where H-4895 is listed, just take the maximum load, multiply it by 60 percent (.60), and you'll get a load with a velocity of 1500 to 2100 fps, depending on the cartridge. I tried it, and it works.

With the 25-06 Remington, Hodgdon lists a maximum load of 43.0 grains of H-4895 with the 100-grain bullet, which calculates out to 25.8 grains. I reduced this a bit more by using 60 percent of their starting charge of 40.0 grains, or 24.0 grains. With this charge, velocity was just right at 1884 fps with the TS-X bullet, and accuracy averaged a stellar .59-inch.

In the tried and true 7x57mm Mauser, for 140-grain bullets, Hodgdon's maximum load is 37.5 grains, and 60 percent of that is 22.5 grains. This propelled the Barnes 140-grain TS-X along at 1523 fps, and was accurate, too -- another .59-inch average.

Alas, I must report failure in the third cartridge in which I tried the "60%" rule -- the 9.3x62mm. Hodgdon doesn't list data for this cartridge, but I had previously used 57.0 grains of H-4895 with the 232-grain Oryx bullet, so I just tried 60 percent of that, or 34.2 grains. Velocity was okay, at 1470 fps, but the extreme variation was 258 fps, the standard deviation was (gasp!) 134, and groups averaged a disastrous 1.46 inches. Maybe somewhere out there is a happy H-4895/232 Oryx load, but this isn't it.

### Cast bullets

Cast bullet technology has come a long way in the past few decades, and you don't even have to cast your own. Good commercial cast bullets for rifles abound.

The best source of loading data on cast bullets in rifles is the *Lyman Cast Bullet Handbook*. Mine is the Third Edition, and it has loads for 78 cartridges that are suitable for turkey hunting. Cast bullet loads for representative calibers are shown in **Table 2**. We'll look at the 270 and 30-30 Winchesters, the good ol' 30-06 Springfield, and 375 H&H Magnum as examples.

We seldom think of the great 270 Winchester as a low-powered wonder, but with cast bullets, it can be. Lyman bullet #280473 that weighs 124 grains when cast from #2 alloy can be driven at 1698 fps with 12.0 grains of Unique, and at 1587 fps with 11.0 grains of Red Dot.

In the 30-30 Winchester, loads for cast bullets from 115 to 173 grains are given. A typical charge of 14.4 grains of SR-4759 gives 1529 fps with the 151-grain #311440 bullet.

Moving to the 30-06 Springfield, 21.0 grains of 2400 with #311440 produces 1739 fps, and 31.0 grains of IMR-3031 clocks at 1775 fps. All of these should reliably harvest turkeys without tearing up Thanksgiving dinner, or terrorizing Farmer Jones' Holsteins. The bottom line is, if you even think that you want to try cast bullets, get the Lyman manual, and try their loads in your rifle.

### Safety In The Work Place

We must conclude with a serious word of caution: Most of these loads for the larger cartridges occupy only a fraction of the case volume, so it is possible to get a double—or even triple—charge of powder in the case. Before seating the bullets, shine a flashlight into each and every case and ensure that it has the right amount of powder in it. Also, as you test loads, be sure that every bullet has exited the barrel. If you don't see a hole in the target after each shot, pull the bolt and look down the barrel. Firing another round onto a bullet stuck in the barrel will not be fun. Just pay attention to detail, load safely, and enjoy the fruit of your labors -- a fine wild turkey dinner.

**Table 2 Selected Cast-Bullet Rifle Loads for Turkeys**  
Source: *Lyman Cast Bullet Handbook, Third Edition.*

Cartridge	Barrel Length (in.)	Case	Primer	Bullet Weight (gr.)	Powder Number	Powder Charge (grs.)	Vel. (fps)
22 Hornet	24	Win.	Win. 116	45	SR-7625	6.0	2005
222 Remington	22	Rem.	Rem. 7 1/2	54	Green Dot	7.4	1980
223 Remington	24	Fed.	Rem. 7 1/2	54	SR-7625	8.3	1950
222 Rem. Magnum	24	Rem.	Rem. 7 1/2	54	Unique	9.5	2195
22-250 Remington	26	Win.	Win. 120	54	Red Dot	7.0	1828
220 Swift	24	Win.	CCI-200	54	2400	10.5	1730
243 Winchester	26	Rem.	Rem. 9 1/2	95	SR-4756	10.0	1550
6mm Remington	24	Rem.	Rem. 9 1/2	95	SR-4759	9.0	1498
25-06 Remington	26	Rem.	CCI-200	112	IMR-4198	27.5	2174
270 Winchester	26	Win.	Win. 120	124	Unique	12.0	1698
7x57 Mauser	24	Fed.	Fed. 210	135	Unique	15.0	1850
30-30 Winchester	26	Win.	CCI-200	122	H-4895	24.3	1661
				151	SR-4759	14.4	1529
30-06 Springfield	26	Win.	Win. 120	151	2400	21.0	1739
					IMR-3031	31.0	1775
9.3x62mm Mauser*	23.6	Rem.	Rem. 9 1/2	135	W-231	10.0	1416
					SR-4759	30.0	
(*author's loads)							
375 H&H Magnum	24	Win.	Win. 120	249	Blue Dot	24.5	1750

Notes: Do not reduce these loads; increase only to the maxima published in the Lyman loading manual. Until you gain experience with reduced loads, be certain that every bullet has exited the barrel. Be especially careful to avoid double charges.

Benchrest competitors go to extreme lengths to reload cartridges on the cutting edge of perfection.

# Really Fussy Reloading

By JACOB GOTTFREDSON

**THE TERM BENCHREST** is often thrown around arbitrarily, each having a somewhat different meaning. This chapter concerns itself with competitive benchrest, which in current terms includes traditional 100/200-yard, 1000-yard, Hunter, and F-class competition. There are, of course, literally thousands of benchresters who fit this description, who are not competitors, but whose goal is the same: Pure accuracy. That is: Accuracy for accuracy's sake.

Advances in rifles, components, and wind flags over the past several years have raised the bar to an incredible level. In 100/200-yard competitive benchrest, for example, one cannot place—given that conditions are reasonable—unless one's aggregate groups are in the teens. At the National Championships most, if not all, of the top 20 finishers will have aggregates of five 5-round groups in the teens at both 100 and 200 yards. Performance at that level is not luck; it is a fierce determination to be perfect.

There are a great many things involved in shooting at the level of the modern day benchrest competitor. Stocks must be stiff and must ride the front and rear bags correctly. Actions must be smooth and fast operating with perfect ignition, and built to exacting tolerances. Scopes must be reliable enough to perform perfectly every time. Finding a barrel that will shoot in the teens is a difficult and costly endeavor. Added to all that is technique at the bench, the ability to read wind flags correctly, and the type of front and rear rests used to hold the rifle.

But there is one remaining technical aspect of the game to master in order to produce aggregates that will put the competitor in the winner's circle: Reloading.

### Reloading for Competitive Benchrest

Reloading to a benchrest competitor has become synonymous with the term tuning. While it is not generally true for 1000-yard and F Class competitors, traditional 100/200-yard Unlimited and Varmint class shooters reload after each 10- or 5-round group, respectively. It is not uncommon to see a competitor go to the line with 2 or 3 different reloads to see which will perform best on that day in those conditions. And that sometimes continues throughout the day as the temperature and conditions change. In the Varmint classes, the competitor has seven minutes to complete his or her 5-round group on the record target. At the bottom of the same target is a sighter target that the competitor can shoot at as many times as he or she wishes during the seven-minute time limit. That gives the shooter time to test different reloads. He or she often spends part of that time "tuning" the load for the rifle and for the present conditions on the sighter target.

### The Benchrest Case

Cases vary in size from the diminutive 222 and 6 PPC in traditional benchrest to the 308 Baer and larger in 1000-yard benchrest. The goal, however, is the same: to make the cases as identical to one another as possible. If ignition and propulsion of the bullet have to be identical to put each round in the same hole, the boiler room has to be identical in configuration, and so does release of the bullet.

To accomplish that, benchrest competitors make the primer pocket and flash hole uniform from case to case, as well as length and weight. But making the cases all the same is only part of the chore. To reduce non-concentric reloads and to ensure proper release, necks are outside neck-turned and loading is achieved in custom dies. Typically chambers are less than

SAAMI spec and are called tight neck chambers. A factory cartridge will not fit in these tight neck chambers. The shooter turns the necks, removing material until the wall thickness is the same all around the case, and the neck wall thickness plus the bullet loaded is only .0005- to .002-inch less than the diameter of the chamber's throat.

### Benchrest Bullets

Without exception (at least that I am aware of), competitive 100/200-yard benchrest shooters use bullets made by individuals who specialize in making bullets just for that activity. Barrels are produced by quality barrel makers such as Hart, Krieger, Shilen, and Lilja, and barrel twists are generally made to give the bullet the exact rotation necessary for accuracy. While boattail bullets are being used by a few competitors for traditional 100/200-yard benchrest, the

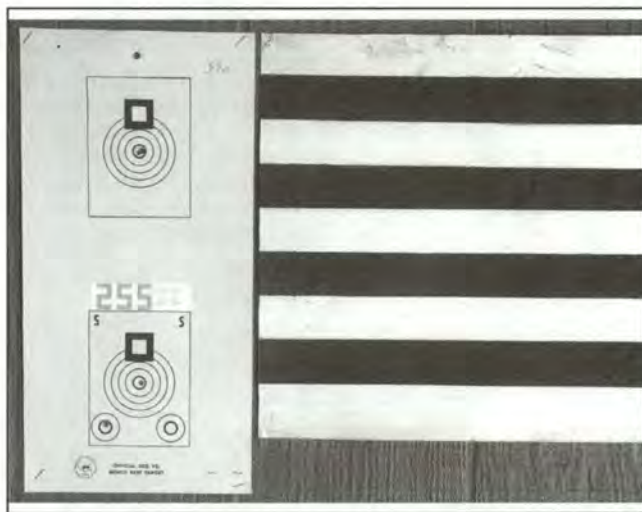

A typical 100-yard benchrest target with sighters and a 5-round .196-inch group. A mirage board is placed next to it to aid the shooter in determining wind speed.



Shooters at the 2003 National Championships in Phoenix, Arizona, waiting for the command to commence firing. (Turk Takano photo)



Competitors at the National Championships set their wind flags prior to competition. Most shooters manufacture their own flags with what they believe will give them a better handle on the wind's speed and direction. Daisy wheels are used to gauge wind speed. The tails also denote wind speed. Double blades give the shooter some idea of the wind's angle with respect to the bullet's travel. The white wind probe in the foreground with the inverted red plastic glasses is the invention of Gene Beggs, his theory being that the crosswind perpendicular to the bullet's flight is much more influential than the angle component. (Turk Takano photo)

majority use flat-base bullets on the small-for-caliber weight side. One thousand yard competitors, on the other hand, make good use of boattail bullets, most from makers like Berger and Sierra. Hunter benchrest competitors often use small-for-caliber bullets, which are primarily flat-base custom-made bullets as well.

Not every custom made bullet works well in every "hummer" barrel (*if there is such a thing*). Nor does every lot of the same bullet work to produce teen eggs. Bullet jackets of exacting quality are not always available. To shoot to the standards of current benchrest competition, the bullet's center of gravity and center of form have to be identical. The ogive, shank, and pressure ring have got to be identical as well. Individuals who produce bullets for sale for the benchrest game do not do so for big bucks. To be sure, the manufacture of custom benchrest bullets is a labor of love. Many competitors make their own bullets on very precise forming and pointing dies.

### Benchrest Powder

Reading the match reports of benchrest matches gives some idea of the actions, scopes, barrels, primers, cartridges, bullets, powders, and loads used by today's competitors. However, although these reports are true in general, they are

not always true exactly. Competitors are required to fill out an equipment report prior to the match. They make the best guess of the rifle and load they will be using. But as the competition progresses, they might change barrels, or rifles, or powder, or bullets, or amount of powder, etc. in an effort to stay competitive. The equipment reports are not revised.

While it is not universally true, many competitors change powder amount or powder type throughout the day in an effort to stay tuned. Frequently used powders for the traditional 100/200-yard benchrest are Hodgdon H322 and Vihtavuori N-133. However, even within powder types, lots will vary in how hot they are. Hodgdon H322 for example was made in Scotland for several years, but



A rail gun whose driver has just finished a match. Spent cases and live ammo are retained within the leather ring used to catch the cases as they are thrown from the action. Note the simplicity and organization of the shooter's bench layout. (Turk Takano photo)

is now being manufactured in Australia. There are also variations of H322, namely T322 and G1322, which are faster and slower respectively than H322. The bottom line is that keeping up with powder types, lots, and amounts that will shoot in any condition consistently is problematic.

There are considerably more cartridge, powder, and bul-



**Turk Takano, National Heavy Varmint Champion, waits for the next match. A few things of interest here: 1. the organization of his bench; 2. the wind pushing the tails of the flags in the background; 3. the difference between's Turk's Farley front rest and the one on the bench behind him.**

let variations among Hunter and 1000-yard benchrest shooters than among 100/200-yard traditional benchresters. Consequently, powder choice is also expanded, as are the difficulties with choosing a bullet, seating depth, and powder amount that will reduce velocity spread and standard deviation to single digits, a necessity for long-range precision.

### The Reloading Process and Tuning

After case preparation and fireforming have been completed, it is time to begin tuning the load to the barrel.

One critical item is determining bushing sizes. Let's assume that you turned the neck to .0125" and your cartridge is a 30-caliber. Assume further that your bullet's shank or pressure ring is .308". The loaded case neck measurement is therefore .308" + 2x.0125" = .333". A bushing is needed to size the neck approximately .002" less than that or .331". Order bushings from .330" to .333" to start. It will depend on what grip is required and what produces the best accuracy. One might settle on a .334" bushing for a 308 Winchester, but a .329" bushing in a 300 Winchester Magnum. Benchresters, on the other hand, using a .261" chamber neck for the 6 PPC might turn necks to .0086" and use a .259" bushing in a Wilson seating die. .243"

+ 2x.0086" = .2602", which results in .2610" - .2602" = .0008" clearance between the neck and the chamber wall for a tight neck chambering. The bushing sizes the neck with bullet from .2602" to .2590" = .0012" grip.

Most 100/200-yard traditional benchrest competitors use Wilson neck dies or custom dies, both of which accept Wilson bushings. Many 1000-yard benchresters and those using larger cases use Redding and other manufacturers' benchrest neck-sizing dies, as well as custom dies. Many of them use Wilson bushings or supply their own. Titanium nitride coated or carbide bushings last much longer,

scratch less, and result in a better finish on the neck, but they are a bit more expensive. The important thing, however, is the internal diameter that will produce the correct neck size to grip the bullet.

Using one of many methods to know when the bullet is seated just at the lands, measure the length of the loaded



**Several of the biggest names in the game were caught on film together in 2003. On the left is Charles Huckaba, three-time National 4-Gun Champion, three-time National Unlimited Champion, and World Record holder. Next to him is the great Tony Boyer, many times National Champion, World Record holder, and holder of many more points in the Hall of Fame than anyone else—considered the best in the game for the past 15 years. Standing and looking at Tony is Alan "Allie" Euber, also many times National Champion, World Record Holder, and second in the Hall of Fame. Standing at the far right is Pat Hurley, and seated is Howard "Howie" Levy, both top shooters in the benchrest game with several Hall of Fame points. They are all gathered near their reloading boxes used during the competition. (Turk Takano photo)**



Cases are meticulously weighed and separated, particularly in long-range benchrest events. Identical case dimensions and weight are necessary to control velocity and pressure variation. Large velocity spreads produce non-competitive vertical dispersion. Modern digital scales speed up the process. They are capable of AC or DC power, are small and easily packed, and can be used outdoors with the use of a clear plastic box. The readout is clear and not easily confused.

cartridge from case head to ogive. Set the seating die to seat the bullets at this exact position. Overall length varies due to the variation of the bullet's point or meplat. The ogive is a more stable location on the bullet. Jot this measurement down. Now screw the seating die in to just touch the bullet. Seat another bullet and check the ogive again to see that it matches the one you started with.

Now you know exactly the setting of your seating die to make the chosen bullet just touch the lands, and, consequently, you know where the bullet is in relation to the chamber. But remember, if you run out of that lot of bullets, you will have to measure the ogive of the new lot of bullets and adjust the seating die to match the new ogive, placing it in the same relation to the lands that you ended up with for the most accurate load. This is accomplished quickest by measuring the ogive from the base of the bullet. If the new lot varies from that measurement, move the seating die by that amount. After a few hundred rounds have been fired through the barrel and the lands erode, the bullet will sometimes have to be moved forward to reestablish the bullet/land relationship.

Load the first set of cases to be fired with the bullet just touching the lands. Later you will determine whether the barrel likes the bullet hard into, just touching, or off the lands.

Make sure the primers you have chosen are seated just below the primer pocket. Set the primed cases upright on their head on a hard, flat surface. If they stabilize immediately, primer depth is probably ok. If they rattle back and forth



Case necks are turned so that wall thickness is consistent throughout its circumference. Variations of only .0001-inch are achievable with care. An expansion mandrel that fits the turner's mandrel precisely should be used. Many shooters turn the necks more than once with a series of turners to achieve the level of consistency they require. A K&M turner is shown. Many competitors use the Nielson turner for 6PPC and other small cases.

before becoming stable, the primers are sticking above the head of the case. You will have to deepen the primer pockets slightly.

Start with a powder load about 10 percent below maximum in the manual.

Benchrest shooters tune at the range by taking all their reloading gear with them. This is helpful when completing the next step

Load three rounds at 10 percent below maximum. These will be foulers and sighters only. Load another five rounds at 10 percent below maximum. Continue loading five round sets, increasing powder about two percent each time until you are one percent above maximum in the book. For example, a 6PPC will take approximately 30 grains of Vihtavuori N-133 at maximum; start at 27.5 grains and work up. Be extremely cautious about going above maximum load. Keep a careful watch of your cases and bolt throw as described below.

Draw a 1-, 2-, or 3-inch grid on a sheet of plain, off-white paper. For the loads above make the grid at least 7 wide and 5 to 7 grids deep. In a no-wind, no-mirage condition, fire a group at the uppermost cross on the left side formed by the grid. Below is an example of the grid with your fired groups.

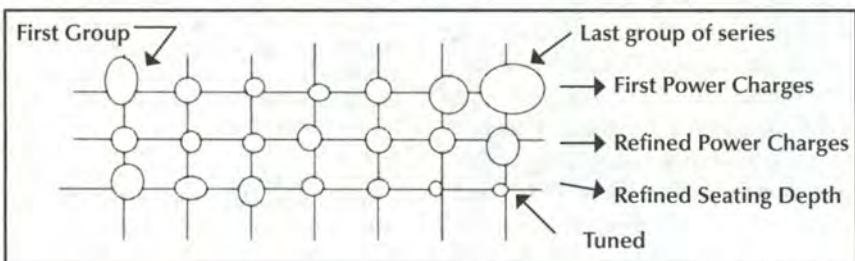





Continuing the cut into the shoulder approximately .03-inch to .04-inch helps prevent a doughnut from forming in the neck. The cut forms a small lip at its end. When the case is fired, that lip is forced to the inside of the case as the brass molds itself to the configuration of the chamber. When the lip moves inside and travels forward into the neck, an irregular venturi is formed that can presumably affect velocity and pressure differentially.

Continue to fire the loads at each grid line progressing from left to right, lightest load to heaviest. Once the barrel harmonics become correct for that bullet/load combination, the group will shrink. You will often see this happen at more than one powder load. Let's assume that the groups continue to shrink as the powder is increased until it reached 29 grains. At 29.5 to 30.5 grains the load opened up again.

Thus it appears that the rifle likes a load with this bullet and powder load around 28.5 to 29 grains. Reload the ammo with the following loads: 28, 28.25, 28.5, 28.75, 29, 29.25 grains. Begin shooting groups on the second row of the grid. Let us assume further for this example that the ideal load among these is 28.5 grains. You have been firing all groups with the bullet just touching the lands.

Load these same cases again using 28.5 grains in all cases. But this time vary the seating depth. Start with .020" off the lands, progressing .005" each time. For example: .020" off the lands, .015" off the lands, .010" off the lands, .005" off the lands, touching the lands, .005" into the lands, .010" into the lands until the mark on the bullet is about as wide as it is long.

In this example the rifle/bullet/powder/seating depth combination liked 28.5 grains with the bullet hard in the lands.

You now have the optimum load for that bullet, powder, seating depth, primer combination in those conditions with the brass you prepared. This required approximately 100 rounds. When you become familiar with a cartridge/barrel combination, this can be done in as little as 20 rounds. Not only that, but if the barrel is not a shooter, you can often tell in 20 to 50 rounds.

As you are shooting your first groups with varying powder loads note:



Case concentricity is checked to insure that the case will be axially aligned with the chamber. Check the body as well as the neck and a seated bullet. Do so prior to sizing, with a bullet seated, and again after firing. If the loaded and/or unloaded cartridge is not concentric, this procedure will allow the reloader to determine whether the sizing die or the chamber is at fault.

1. Velocity
2. Spread
3. Standard Deviation
4. Atmospheric pressure
5. Altitude
6. Humidity
7. Temperature
8. Brass stress

What is brass stress? Prior to shooting your brass, measure the head just forward of the extractor groove. Note that measurement. As you fire the brass, keep track of that measurement. You will note that the brass expands at that point approximately .001" immediately and remains at that measurement until you reach maximum load. At or just above maximum stress, the brass will expand to .003" or more. If you use that load, the brass will not last long and will become stiff on bolt removal. Worse, you risk separating the head from the case. It is best to back off to a load that produces less stress.

Primers will sometimes give you an indication of pressure as well, as will bolt operation. Primers often flatten, pierce, or cup where the pin hits, with metal extruded out like a pebble dropped in water, which you can see or feel with the finger. The bolt will be difficult to lower if the shoulder is being expanded tightly against the chamber. The bolt will be difficult to cam up to extract the case if the head of the case is expanding excessively. Also, while performing this exercise, keep track of velocity increase with each greater powder charge. At some point, you will note that velocity increase diminishes with the same amount of powder increase until almost no increase in velocity is being made ... another sign that you are loaded at or past maximum.

When you think you have the optimum load, fire a statistically significant series to verify it and to note what it is. As an example, Statistical Process Control analysis requires twenty-one 5-round groups be fired to establish that the load is "in control". Doing so, of course, requires approximately 200 rounds when added to the tuning process. But remember, doing all that prior to competition has partially deteriorated the gilt accuracy of a barrel. Feel like you can't win?

Try different bushings to optimize length and amount of grip on the bullet. Some rifles prefer more grip on the bullet than others.

After cleaning the necks, but prior to sizing the cases, run them through a concentricitor to check runout. This will tell you whether firing is damaging the case. For example, if the bolt is not perpendicular to the bore, the case is forced into a banana shape, making it thin on one side and thick on the other. Groups will suffer greatly if this happens.

Run the cases through the concentricitor again after the body die has sized them. If the cases were concentric prior to sizing, the bolt/chamber relationship is OK. If the case shows runout after sizing, the die is not sizing correctly or is out of round. Check both the body and the neck for runout.

One hundred/two hundred-yard benchrest competitors use a powder measure that throws charges into small cases. With the best measures, the powder thrower is only accu-

rate to about +/- .1 grain in 30 grains. This small percentage, however, is not enough to vary velocity spread and standard deviation appreciably at these short ranges. Most benchrest competitors do not use a scale during the match, relying entirely on the thrower's accuracy. One thousand-yard shooters may wish to be more precise. A 25 fps variation in velocity from round to round will make an appreciable difference in vertical point of impact at the longer ranges.

The point here is that you will want to think about case configuration and size as well as the range and your intention when you place the powder in the case. Check the accuracy of your powder thrower and your ability to throw each charge consistently. You may choose to measure each load on a scale. Note that scales have a certain amount of inaccuracy as well. Check velocity spread and standard deviation of the rounds you are loading. Best loads are usually those whose powder load is full enough that the powder cannot be moved when the case is shaken. However, this is not a haphazard filling of the case. Each case should be filled using a drop tube, and the powder thrower should be dumped slowly, allowing the drop tube to deliver powder at a constant rate so that each case fills the same as the others.

Benchrest, a pure precision sport, is all about bullets, barrels, and tuning. Many competitors buy 20 to 40 barrels per year searching for that illusive teen aggregate barrel. They go through thousands of bullets trying to find those that are near perfection and fit the barrel's groove correctly. When a

good powder and powder lot are found, competitors often buy a great many pounds of it. And finally, they spend hundreds of hours putting together really fussy reloads. If after all of that, they can find a combination that will produce consistent teen aggs or .250" aggs. throughout the 100- and 200-yard grand agg. as well as the 2-, 3-, and 4-gun aggregate, they will do very well.

Most of the best shooters have a few things going for them that the rest of us do not. They invest heavily in equipment. They practice and shoot matches often. They also have a natural gift for being able to compile and analyze wind data during a seven-minute match like a computer. But their real talent lies in being able to know when a rifle is not tuned and how to quickly tune it during a match. For example, they know that although some loads will shoot a hole in a no-wind condition, that same load does not shoot as well as another load in the wind. They know when to go up or down on the powder load to reduce group size. Benchresters' fussy reloading is done for a valid reason: to win.



**A rather old, but typical, match reloading bench. The loading box in the background holds all the tools necessary for loading at a match. The press in the foreground is manufactured by Hood and is made to fit in loading boxes like the one shown. The sizing die in the press is custom made to just bump the shoulder, decap, and size the body approximately .001-inch to allow fast feeding in the action. The seating die on the left is a Wilson Straight Line Seater. On the far left are a Crazy Kloth to clean the case, a cartridge block with spent cases, Imperial Die Wax, a K&M primer seater, and primers. The powder thrower is an original Culver measure with a drop tube installed, behind which are match bullets. This bench is ready to reload cases for competition.**

Can steel shot be reloaded? Absolutely. Is it safe to reload steel shot? Absolutely again, provided you are willing to follow published reloading data and directions carefully. Do you need special equipment? Not really.

# Reloading Steel Shot

By TOM ROSTER

**NOW THERE ARE** important differences in the hardness and weight of steel shot when compared to lead shot. So reloaders must become accustomed to the new demands steel shot places on shotshell reloading techniques and ballistics. Such things as the type of wad required, the type of powder required, the final weight of the shot charge thrown and the size of the bar or bushing cavity needed to throw that weight, are also different from loading lead shot. In addition, the relative non-compressibility of steel shot and the demands it places on guns and ballistics are areas in which shotgunners will have to become knowledgeable.



Tom Roster (standing behind shooter) provides shooting instruction to a waterfowl hunter using his own steel shot target reloads.



Waterfowl hunters were the first to be affected by the mandatory use of steel shot, but nontoxic shot usage is now also increasingly being mandated for upland bird hunting. Reloading offers the shooter the opportunity to assemble custom steel loads in exactly the shot sizes desired.

## Steel Shot Is Different

Steel shot differs substantially from lead shot in terms of hardness. Lead shot is quite soft. On the Diamond Pyramid Hardness (DPH) scale, most chilled lead shot alloyed with antimony will test about 30-35 DPH, depending upon the actual antimonial content.

Steel shot pellets are fabricated from low carbon steel wire which is chopped, then headed, ground, or rolled into a ball shape and then may be polished in to an even more spherical shape. Such working with steel wire tends to case-harden the ball.

To render a steel ball soft enough to preclude barrel damage, even if it is loaded in a properly designed plastic shotcup wad that prevents it from contacting the barrel interior, it must be annealed. Proper steel shot for shotshell loads as defined by the Sporting Arms and Ammunition Manufacturers Institute (SAAMI) should have an average maximum DPH no higher than 90 (ANSI/SAAMI Z299.2-1982). Steel shot, even of the proper hardness level, then, is about three times harder than lead shot.

Consider, also, the difference in weight. Iron has a specific gravity of 7.8, and lead a specific gravity of 11.4. Iron, therefore, is only about two-thirds as heavy as lead.

Shot charge weights thrown on factory high-speed loaders and home reloading presses have always been dropped by gravity through a pre-drilled cavity. The volume of the cavity determines the amount of shot that can ultimately pack into the cavity, and thus ultimately the amount of shot that will drop into the shotshell. The weight of the shot charge, though, is actually a function of the density of the material being loaded.

What we actually do when we use a given bar or bushing to throw a shot charge is to throw a volume or an amount of shot. The weight of that shot charge, however, is determined by the specific gravity of the metal from which the pellets in the shot charge are made. Therefore, a given bar or bushing will throw the same amount of either steel or lead shot (assuming the same pellet size), but the weight of each of these shot charges will be different.

As an example, a bar designed to throw a true 1-1/2 ounce charge of lead shot will not throw a 1-1/2 ounce charge of steel shot. It will throw the same number of steel pellets of the same size as the lead pellets, but the volume of the steel charge thrown will weigh only about 1 ounce, while the volume of the lead charge thrown will weigh about 1-1/2 ounces. So, the bar or bushing that throws a 1-1/2 ounce charge of lead 6's, for example, will throw about the same number of steel 6's, but that charge of steel will weigh only about 1 ounce.

These two important differences—weight and hardness—make reloading steel shot a different ball game for the reloading enthusiast. So, when reloading steel shot you cannot use the same shot bar or bushing used to throw lead shot or vice versa. The following table lists approximately equal shot charges of lead and steel shot.

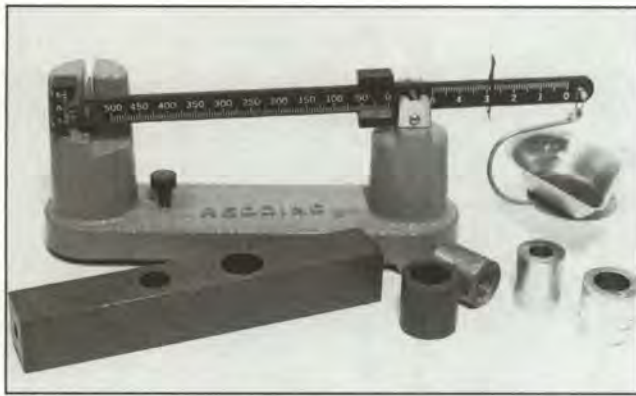

The most important tool for any steel shot reloader is a good scale. It should be used to adjust powder and shot bars or bushings to throw within the tight limits demanded by steel. Then it should be used frequently during the reloading process to check actual powder and shot charges being dropped.

#### VOLUMETRICALLY EQUIVALENT STEEL AND LEAD LOADS

STEEL		LEAD
1/2 Oz.	≡	3/4 Oz.
5/8 Oz.	≡	7/8 Oz.
3/4 Oz.	≡	1 Oz.
7/8 Oz.	≡	1-1/4 Oz.
1 Oz.	≡	1-3/8 Oz.
1-1/8 Oz.	≡	1-1/2 Oz.
1-1/4 Oz.	≡	1-3/4 Oz.
1-3/8 Oz.	≡	1-7/8 Oz.
1-1/2 Oz.	≡	2-1/8 Oz.
1-5/8 Oz.	≡	2-1/4 Oz.
1-3/4 Oz.	≡	2-1/2 Oz.

#### APPROXIMATE PELLET COUNTS OF VOLUMETRICALLY EQUIVALENT STEEL AND LEAD LOADS

Pellet Size (American Standard)	Steel		Lead	
	Load Wt. (Ounces)	Pellet Count	Load Wt. (Ounces)	Pellet Count
4	7/8	164	1-1/4	170
6	7/8	255	1-1/8	251
4	1	187	1-3/8	187
6	1	291	1-3/8	307
2	1-1/8	142	1-1/2	132
4	1-1/8	211	1-1/2	204
6	1-1/8	327	1-1/2	335
BB	1-1/4	87	1-3/4	88
2	1-1/4	156	1-3/4	154
4	1-1/4	235	1-3/4	238
BB	1-3/8	96	1-7/8	94
2	1-3/8	170	1-7/8	165
4	1-3/8	258	1-7/8	255

#### Steel and Lead Shot Size Designations

The diameter of a given name designation for a steel pellet is the same as the diameter of a given name designation for a lead pellet. For example, a No. 6 steel pellet has the same diameter as a No. 6 lead pellet. Both are .110" in diameter.

So, keep in mind that while the weight and hardness of steel and lead shot are different, the pellet sizes are the same.

Since steel shot is offered for reloading in some sizes not currently available in lead, the following table is provided to familiarize the reloader with American shot size designations for the range of shot sizes currently available in steel shot.

#### AMERICAN STANDARD SHOT SIZES

SHOT SIZE (Amer. Stan.)	DIAMETER (Inches)
F	.220
TT	.210
T	.200
BBB	.190
BB	.180
Air Rifle	.175
B	.170
1	.160
2	.150
3	.140
4	.130
5	.120
6	.110
7	.100

#### Steel Shot Wads

Consider now the steel shot wad. A steel shot wad, unlike a lead shot wad, must absolutely prevent the hard steel pellets from contacting the bore interior. It does this by completely containing all the pellets of the steel shot charge in a large capacity shotcup featuring very thick, very dense petal walls. The petal walls so constructed will not allow the pellets to rub-through during bore passage to contact the barrel interior as they often do in a shotcup or shot wrapper used for loading lead shot. Additionally, a steel shot charge must never extend above the top of the shotcup as it often does in heavy or magnum lead loads. So loaded steel shot would make direct bore contact and cause extensive scoring and erosion.

To accomplish this, the typical steel shot wad is molded as a single unit shot container consisting of a shotcup connected directly to an over-powder cup. Unlike a lead wad, there are usually no cushioning posts. The steel shot wad is also made from a much higher density plastic than that used to make a lead shot wad. Additionally, the petals of a properly designed steel shot wad are much thicker than the petals of any lead shot wad. The entire design goal of the steel shot wad is the opposite of the lead shot wad. A lead shot wad is designed to protect the soft lead shot. A steel shot wad is designed to protect the shotgun barrel from the hard steel shot.

#### Delicacy of Steel Shot Loads

No steel shot or lead shot load should ever be assembled without strict adherence to published reloading data. The



While steel shot can be reloaded in the same hulls used for reloading lead, the increased capacity of hulls such as the Federal Gold Medal plastic hull (center) are the best for reloading steel.

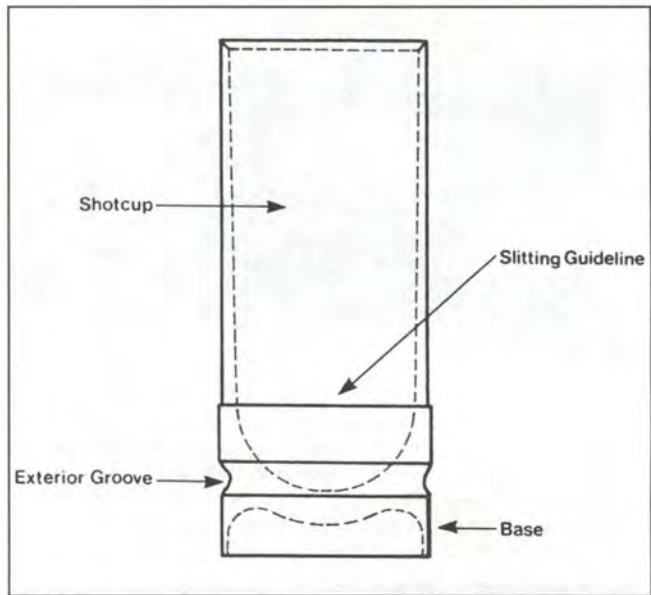

A cross-sectional view of a typical steel shot wad. Note the lack of a cushioning section and the much thicker base and sidewalls than lead shot wads. While most steel shot reloading wads are supplied today with their shotcup portion pre-slit into four or more petals, some still require the handloader to do the slitting.



Steel reloading is much like reloading lead shot target loads in that only a hull, primer, powder, wad and shot are needed as components. Unlike the lead wad pictured here, however, a steel shot wad does not contain cushioning posts, is molded from a much higher density plastic, and contains a much deeper shotcup.

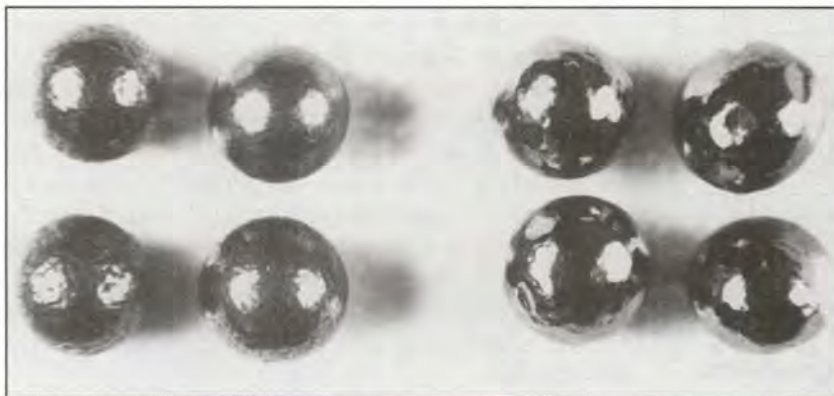

Besides being rounder and more uniform, steel pellets differ from lead shot in other important ways. Steel pellets (left) are much harder and less compressible. These characteristics significantly change the ballistics of steel versus lead loads, requiring the use of different wads and powders than when reloading lead.

velocities and pressures listed for any given load will vary substantially if different components are substituted for those called for in the data, or if the actual weights of powder or shot thrown are lighter or heavier than shown in the data. In effect, shotshell reloading data are recipes to be followed without deviation to achieve the stated ballistic level.

While most reloaders never substitute components, some have developed a cavalier attitude about adhering to the weight of powder or shot called for in lead shot reloading recipes. As an example, the recipe calls for 28.0 grains of Powder Y in a lead reload. But the reloader who has a bushing which throws 30.0 grains of Powder Y uses that bushing instead. He reasons, "That's close enough; what harm can two more grains of powder cause?" And usually, but not always, the reloader escapes harm, although perhaps over time the gun doesn't fare as well.

Such practices are at the very least sloppy. Sloppy reloaders get away with sloppy powder charges loading lead shot, because both lead shot and the attendant wad column are soft and quite compressible. With compressible lead shot and its compressible wad column, much of the excess energy (pressure) of an overcharge of powder can be absorbed by the lead

pellets crushing and the wad column collapsing. This tends to keep the pressure excursion from reaching a truly dangerous level.

With steel shot, on the other hand, a "slight" overcharge of powder can often be dangerous rather than merely sloppy. Steel shot and its cushionless, relatively hard wad are unable to compress significantly to absorb the excess energy of overcharges and thus lower the peak value of chamber pressure. Let's look at an example. A 2-3/4" 12-gauge 1-1/8 oz. steel reload attains a velocity of 1304 fps at 11,400 psi. This is a perfectly safe working pressure level for 12-gauge shotshell loads assembled with any shot type. But if this same steel load is assembled with just 3.0 more grains of powder than called for in the recipe, the average chamber pressure level rises to 14,500 psi, which is 3000 psi above the SAAMI standard for maximum average chamber pressure for 12-gauge, 2-3/4". With steel shot, once safe maximum pressure levels are approached, just a few more grains of powder causes a precipitous rise in pressure. The leaves little margin for careless overcharge error.

The lesson is clear: Steel shot is less forgiving and more

likely to develop dangerous pressure levels as the result of an overcharge than lead shot in a similar load. Be certain when loading steel shot your loading tool throws an average powder charge which deviates no more than one-half (1/2 or 0.5) of one grain from the powder weight and no more than twenty-five (25.0) grains from the shot weight called for in the loading recipe. Failure to do so could result in dangerous pressure levels that could result in serious injury or death to persons and damage to firearms and property.

### Loading Steel Shot

After having purchased steel shot of the correct hardness together with properly designed steel wads, you are now ready to reload. The first thing the reloader must understand, however, is that not every reloading press is designed to handle steel shot. The problem stems from the fact that unlike soft lead pellets, steel pellets are so hard the reloader will not be able to shear-off or flatten steel pellets, should they become caught between the shot bar or bushing and the loading tool head plate or measure assembly in which the charging bar or transport device moves.



The internal ballistics of steel shotshells require that the slower burning propellants like HS-7 and Universal from Hodgdon or 800-X and SR 4756 from IMR be used in steel shot reloads rather than the faster burning propellants common to lead shot reloads.

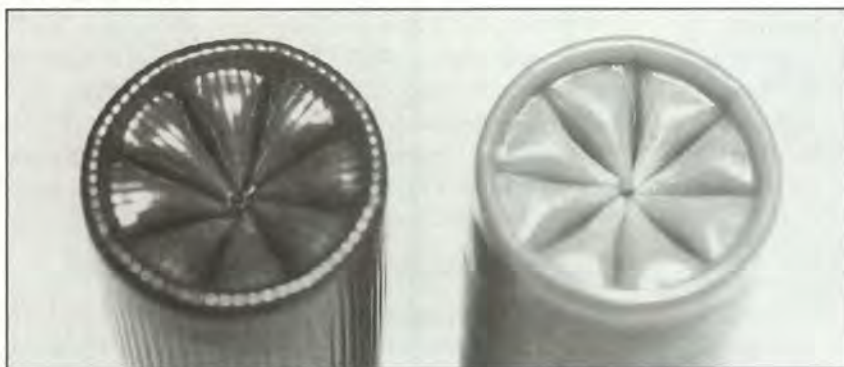

Steel reloads require good quality crimps with firm closures to provide the resistance necessary to insure good combustion from the slower burning propellants used in steel reloading.

The Ponsness/Warren Du-O-Matic 375C press by virtue of its dual head allows the assembly of any length 12- or 10-gauge steel reload. The 375C requires no steel shot converting kit and is ready to go for reloading steel, lead or bismuth. The high volume Ponsness/Warren L/S-1000 is the only progressive press specifically designed for reloading steel shot, besides lead and bismuth. It is available in 12-gauge 2-3/4" and 3" or 10-gauge 3-1/2".





The new RCBS Mini-Grand is another excellent single-stage reloading press for steel shot. With the purchase of an RCBS steel shot conversion kit, the Mini-Grand can reload steel in 2-3/4", 3" and 3-1/2" 12-gauge.

An additional problem with reloading steel shot is that larger steel pellets will tend to be loaded as compared to lead. While probably the majority of shotshell loads that have been assembled with lead shot on reloading presses have been loaded with size No. 4 shot or smaller, the majority of shotshell loads assembled with steel shot on such tools will be loaded with size No. 6 shot or larger. The larger the pellet size being loaded, whether lead or steel, the more difficult it is to transport the shot from the shot bottle or hopper through the charging bar and down the drop tube into the shotshell without the pellets bridging in the narrow confines of the transport parts.

The solution to the jamming problem is for the reloading tool manufacturers to offer special charging bars which feature soft, long-wearing inserts near the shot cavity to alleviate charging-bar jamming problems. The solution to the bridging problem is to offer transport parts with larger ID's to minimize the bridging problems associated with loading larger shot. All of these parts are inexpensive and can be easily retrofitted to existing home reloading presses.

One press – the MEC Steelmaster – comes fully equipped to reload steel shot. All that is necessary is to purchase the appropriate MEC steel shot bar for the steel shot charge weight and pellet size to be loaded. All other MEC single-stage presses can also be used to reload steel shot, but they

The MEC Steelmaster single-stage press comes automatically set up for steel reloading. It is available to load from 2-3/4" 12-gauge through 3-1/2" 10-gauge, plus can also load lead shot simply by changing out the transport bar.



Tom Roster is one of the world's pioneers in educating hunters about the use of steel shot and developing steel shot reloading data. The author has written several steel shot reloading manuals for various companies and was awarded a U.S. patent for a steel shot wad still being sold as a reloading component today.

require a MEC steel shot conversion kit. With MEC, a separate Sizemaster or other MEC single-stage press is needed to load 2-3/4", 3", or 3-1/2" 12-gauge or 3-1/2" 10-gauge steel.

The relatively new RCBS Mini-Grand single-stage press is also designed to load steel shot as well as lead. However, an optional RCBS steel shot conversion kit is necessary plus the appropriate steel shot charging bushings. Unlike MEC presses, this RCBS press can load from 2-3/4" to 3-1/2" 12-gauge steel loads without need for separate tools.

Steel shot reloaders should also look carefully at the Ponness-Warren Du-O-Matic 375C single-stage tool. This press by virtue of a dual tool head can reload either 3-1/2" 10 gauge or 2-3/4" to 3-1/2" 12-gauge steel loads **without** the need for a conversion kit. If you want high volume steel reloading, the press of choice is the P-W progressive L/S-1000, which can also reload steel without need of a conversion kit. With the L/S 1000 each pull of the handle turns out a fully finished round of steel shot.

#### Loading Steel Pellet Sizes Larger Than No. BB

There are several steel pellet sizes currently being sold to the reloading market which are larger than No. BB (.180"). My experience is that no reloading press currently made will handle steel pellet sizes larger than No. BB accurately, if at all. The problem is that without continuous vibratory assistance pellets larger than this diameter excessively bridge in the press and/or pack inaccurately into bars and bushings. It is recommended that the reloader use the hand-weighing method only when loading steel or lead pellets in all shot sizes larger than No. BB.



## Steel Shot Powders

Because of the hardness of the steel pellets, the stiffness of the plastic in the thick steel shot wads necessary to provide adequate barrel protection and the lack of a cushioning section in such wads, pressures in steel loads rise much faster and more steeply than in lead loads. As a consequence the fast burning propellants like 700-X, Clays and Red Dot which lead shot reloaders are accustomed to using to assemble, say, 1-1/8 oz. 12-gauge lead shot target loads will not work for reloading 1-1/8 oz. 12-gauge steel reloads.

Instead, when reloading steel much slower burning propellants are necessary to keep chamber pressures in check and to obtain the 1300 fps or higher velocities desired by most hunters when shooting steel.

The reloader will commonly be using slow-burning powders like IMR's SR-4756 or 800-X, Hodgdon's Universal, Winchester's 571 (now sold by Hodgdon as HS-7), and Alliant's Blue Dot and STEEL to propel 1-1/8 oz. and even one oz. 2-3/4" and 3" 12-gauge steel loads and heavier 3-1/2" 12- or 10-gauge steel loads. Hey, it's a whole new ball game, and getting used to new propellants is just part of the change from lead.

### Throwing Accurate Powder Charges

In order to throw the correct charge of powder called for in any steel shot reloading recipe, you will first need the correct powder bushing, then you will probably need to modify it. No manufacturer can supply you with a powder bushing that throws the exact powder charge called for in a reloading recipe. Reloaders are cautioned that bushing charts are guides only and should be interpreted as indicating approximate powder weights only.

To throw correct powder charges for any reloading recipe it is recommended that you own a good 505 to 1010-grain capacity powder scale, and use it regularly. If your powder bushing is not throwing the weight of powder desired, either purchase a different one or be prepared to alter the bushing. This can be done by either reaming it with a round file to increase the weight of powder thrown, or by applying small strips of electrician's tape inside the cavity to reduce the weight of powder thrown. Both alterations are simple, fast and inexpensive means of throwing powder charges easily within the desired  $\pm 0.3$  of a grain of the exact powder charge desired.

### Waterproofing Steel Shot Reloads

Steel shot, because it is made from iron, is subject to rusting if the pellets become immersed in water. Most steel shot pellets are coated with a rust inhibitor that protects the pellets from the oxidizing effects of high humidity and rain. However, the rust inhibitor is not sufficient to prevent rust if the pellets become submerged.

Factory steel loads are going increasingly to a shellac or glue-like crimp sealer or a crimp-center spin to seal the crimp and render the load more waterproof. It is recommended that after crimping, reloaders hunting saltwater

areas—or who otherwise expect their shotshell loads might become immersed in water—seal the crimp of all steel loads to render them waterproof. A couple of drops of candle-wax or fingernail polish applied to the crimp so the sealant closes the crimp center and migrates up the crimp folds will aid greatly in waterproofing the shell.

### Steel Shot Reloading Data And Components

As this is written, happily there is almost a plethora of steel shot reloading data. Reloaders can go to independent sources like Lyman's 4<sup>th</sup> Edition *Shotshell Reloading Handbook* for steel shot reloading data in 10-gauge, all three lengths of 12-gauge and even 16-gauge. Many powder companies such as Alliant and Hodgdon now also publish steel shot reloading data.

Ballistic Products in Minnesota (888-273-5623) and Precision Reloading in Connecticut (800-223-0900) manufacture both steel shot reloading wads in 10- and 12-gauge, sell steel shot itself, and also publish steel shot reloading manuals featuring their line of steel shot wads. There are other sources of steel shot, steel shot wads and data. However, I have not tested other companies' products for barrel damage or for the veracity of their published reloading data for same, so cannot attest firsthand to their safety or utility. The reloader is encouraged to contact the above two companies for steel shot wads, data, and other components.

Due to space limitations, no reloading data are published here. Allow me to add one thing, however. Having assembled, fired and laboratory and field tested perhaps more steel reloads and factory loads than anyone on this planet, I know for a fact that steel shot assembled in a properly designed steel shot wad does not need the addition of buffers, lubes, overshot wads or any other component inside the hull other than the steel shot itself, a good steel shot wad, and the proper powder. The choice, as always, however, is up to the reloader.

### Conclusion

Steel shot reloads can be assembled in the same type hulls and on most of the same reloading presses in which lead shot can be reloaded. But, steel shot needs special wads for proper barrel protection and steel reloads generally need slower burning propellants than lead shot loads to get the same job done. Because of the lack of compressibility of the steel shot ejecta, the reloader must also be more careful than when reloading lead shot to throw accurate powder and shot charges or risk dangerous pressure excursions from steel reloads. With a little common sense and careful attention to detail, anyone can reload steel shot.

To correspond with Tom Roster or to order his recently published 24-page 3<sup>rd</sup> Edition reloading manual on buffered lead and bismuth shotshell loads, instructional shooting videos, or 75-page manual on shotgun barrel alterations contact: Tom Roster, 1190 Lynnewood Blvd., Klamath Falls, OR 97601; (541) 884-2974, e-mail tomroster@charter.net

# THE HANDLOADERS' LIBRARY

## IMPORTANT NOTICE TO BOOK BUYERS

Books listed here may be bought from **Ray Riling Arms Books Co.**, 6844 Gorsten St., Philadelphia, PA 19119, Phone 215-438-2456; FAX: 215-438-5395. E-Mail: sales@rayrilingarmsbooks.com. Larry Riling is the researcher and compiler of "The Handloaders' Library" and a seller of gun books for over 32 years. The Riling stock includes books classic and modern, many hard-to-find items, and many not obtainable elsewhere. These pages list a portion of the current stock. They offer prompt, complete service, with delayed shipments occurring only on out-of-print or out-of-stock books. Visit their web site at [www.rayrilingarmsbooks.com](http://www.rayrilingarmsbooks.com) and order all of your favorite titles on line from our secure site.

**NOTICE FOR ALL CUSTOMERS:** Remittance in U.S. funds must accompany all orders. For your convenience we accept VISA, MasterCard, Discover Card & American Express. For shipments in the U.S. add \$7.00 for the 1st book and \$2.00 for each additional book for postage and insurance.

Minimum order \$10.00. International Orders add \$13.00 for the 1st book and \$5.00 for each additional book. All International orders are shipped at the buyer's risk unless an additional \$5 for insurance is included. USPS does not offer insurance to all countries unless shipped Air-Mail please e-mail or call for pricing.

Payments in excess of order or for "Backorders" are credited or fully refunded at request. Books "As-Ordered" are not returnable except by permission and a handling charge on these of 10% or \$2.00 per book which ever is greater is deducted from refund or credit. Only Pennsylvania customers must include current sales tax.

A full variety of arms books also available from **Rutgers Book Center**, 127 Raritan Ave., Highland Park, NJ 08904/908-545-4344; FAX: 908-545-6686 or **I.D.S.A. Books**, 1324 Stratford Drive, Piqua, OH 45356/937-773-4203; FAX: 937-778-1922.

**ABCs of Reloading, 7th Edition**, edited by Bill Chevalier, Krause Publications, Iola, WI, 2004. 288 pp., illus. Paper covers. \$21.95.

**Accurate Arms Loading Guide Number 2**, by Accurate Arms. McEwen, TN: Accurate Arms Company, Inc., 2000. Paper Covers. \$22.95

**The American Cartridge**, by Charles Suydam, Borden Publishing Co. Alhambra, CA, 1986. 184 pp., illus. Softcover \$24.95.

**Ammo and Ballistics II**, by Robert W. Forker, Safari Press, Inc., Huntington Beach, CA., 2002. 298 pp., illustrated. Paper covers. \$19.95

**Ammunition: Grenades and Projectile Munitions**, by Ian V. Hogg, Stackpole Books, Mechanicsburg, PA, 1998. 144 pp., illus. \$24.00

**Barnes Reloading Manual #3**, Barnes Bullets, American Fork, UT, 2003. 668 pp., illus. \$29.95

**Blackpowder Loading Manual, 4th Edition**, by Sam Fadala, Krause Publications, Iola, WI, 1995. 368 pp., illus. Paper covers. \$27.99

**Cartridges of the World, 10th Edition**, by Frank Barnes & Stan Skinner, Krause Publications, Iola, WI, 2003. 512 pp., illus. Paper covers. \$27.99

**Cartridge Reloading Tools of the Past**, by R.H. Chamberlain and Tom Quigley, Tom Quigley, Castle Rock, WA, 1998. 167 pp., illustrated. Paper covers. \$25.00

**Cast Bullets for the Black Powder Rifle**, by Paul A. Matthews, Wolfe Publishing Co., Prescott, AZ, 1996. 133 pp., illus. Paper covers. \$22.50

**Complete Blackpowder Handbook, 4th Edition**, by Sam Fadala, Krause Publications, Iola, WI, 2001. 400 pp., illus. Paper covers. \$24.99

**Complete Reloading Guide**, by Robert & John Traister, Stoeger Publishing Co., Wayne, NJ, 1997. 608 pp., illus. Paper covers. \$34.95

**Complete Reloading Manual, One Book / One Caliber.** California: Load Books USA, 2000. \$7.95 Each

**Designing And Forming Custom Cartridges For Rifles And Handguns**, by Ken Howell. Precision Shooting, Manchester, CT. 2002. 600 pages, illus. \$59.95

**Early Loading Tools & Bullet Molds**, Pioneer Press, 1988. 88 pages, illustrated. Softcover. \$7.50

**German 7.9MM Military Ammunition 1888-1945**, by Daniel Kent, Ann Arbor, MI: Kent, 1990. 153 pp., plus appendix. illus., b&w photos. \$35.00

**Handgun Stopping Power; The Definitive Study**, by Marshall & Sandow. Boulder, CO: Paladin Press, 1992. 240 pages. \$45.00

**Handloader's Digest, 18th Edition**, edited by Ken Ramage. Krause Publications, Iola, WI, 2003. 256 pp., illustrated. Paper covers. \$22.95.

**Handloader's Manual of Cartridge Conversions, 2nd Revised Edition** by John J. Donnelly, Stoeger Publishing Co., So. Hackensack, NJ, 2002. Unpaginated. \$39.95

**Hatcher's Notebook**, by S. Julian Hatcher, Stackpole Books, Harrisburg, PA, 1992. 488 pp., illus. \$39.95.

**History and Development of Small Arms Ammunition; Volume 2** Centerfire: Primitive, and Martial Long Arms. by George A. Hoyem. Oceanside, CA: Armory Publications, 1991. 303 pages, illustrated. \$60.00.

**History and Development of Small Arms Ammunition; Volume 4**, American Military Rifle Cartridges. Oceanside, CA: Armory Publications, 1998. 244pp., illus. \$60.00.

**Hornady Handbook of Cartridge Reloading, 6th Edition, Vol. I and II**, Edited by Larry Steadman, Hornady Mfg. Co., Grand Island, NE, 2003., illus. \$49.95

**How-To's for the Black Powder Cartridge Rifle Shooter**, by Paul A. Matthews, Wolfe Publishing Co., Prescott, AZ, 1995. 45 pp. Paper covers. \$22.50

**The Illustrated Reference of Cartridge Dimensions**, edited by Dave Scovill, Wolfe Publishing Co., Prescott, AZ, 1994. 343 pp., illus. Paper covers. \$19.00

**Loading the Black Powder Rifle Cartridge**, by Paul A. Matthews, Wolfe Publishing Co., Prescott, AZ, 1993. 121 pp., illus. Paper covers. \$22.50

**Lyman Cast Bullet Handbook, 3rd Edition**, edited by C. Kenneth Ramage, Lyman Publications, Middletown, CT, 1980. 416 pp., illus. Paper covers. \$19.95.

**Lyman Black Powder Handbook, 2nd Edition**, edited by Sam Fadala, Lyman Products for Shooters, Middletown, CT, 2000. 239 pp., illus. Paper covers. \$19.95

**Lyman Pistol & Revolver Handbook, 2nd Edition**, edited by Thomas J. Griffin, Lyman Products Co., Middletown, CT, 1996. 287 pp., illus. Paper covers. \$18.95

**Lyman Reloading Handbook No. 48**, edited by Edward A. Matunas, Lyman Publications, Middletown, CT, 2003. 480 pp., illus. Paper covers. \$26.95

**Lyman Shotgun Handbook, 4th Edition**, edited by Edward A. Matunas, Lyman Products Co., Middletown, CT, 1996. 330 pp., illus. Paper covers. \$24.95

**Modern Combat Ammunition**, by Duncan Long, Paladin Press, Boulder, CO, 1997, soft cover, photos, illus., 216 pp. \$34.00

**Modern Exterior Ballistics**, by Robert L. McCoy, Schiffer Publishing Co., Atglen, PA, 1999. 128 pp. \$95.00

**Modern Reloading 2nd Edition**, by Richard Lee, Inland Press, 2003. 623 pp., illus. \$29.95. The how-to's of rifle, pistol and shotgun reloading plus load data for rifle and pistol calibers.

**Modern Sporting Rifle Cartridges**, by Wayne van Zwoll, Stoeger Publishing Co., Wayne, NJ, 1998. 310 pp., illustrated. Paper covers. \$21.95

**Mr. Single Shot's Cartridge Handbook**, by Frank de Haas, Mark de Haas, Orange City, IA, 1996. 116 pp., illus. Paper covers. \$21.50

**Nosler Reloading Manual #5**, edited by Gail Root, Nosler Bullets, Inc., Bend, OR, 2002. 516 pp., illus. \$29.99

**The Paper Jacket**, by Paul Matthews, Wolfe Publishing Co., Prescott, AZ, 1991. Paper covers. \$14.50. Up-to-date and accurate information about paper-patched bullets.

**Reloading Tools, Sights and Telescopes for S/S Rifles**, by Gerald O. Kelver, Brighton, CO, 1982. 163 pp., illus. Softcover. \$15.00

**Reloading for Shotgunners, 4th Edition**, by Kurt D. Fackler and M.L. McPherson, DBI Books, a division of Krause Publications, Iola, WI, 1997. 320 pp., illus. Paper covers. \$19.95

**The Rimfire Cartridge in the United States and Canada**, Illustrated history of rimfire cartridges, manufacturers, and the products made from 1857-1984. by John L. Barber, Thomas Publications, Gettysburg, PA 2000. 1st edition. Profusely illustrated. 221 pages. \$50.00

**Shotshells & Ballistics.**: Safari Press, 2002. 275pp, photos. Softcover. \$19.95

**Sierra Reloading Manual, 5th Edition: Rifle And Handgun Manual Of Reloading Data.** Sedalia, MO: Sierra Bullets, 2003. \$39.95

**Sixgun Cartridges and Loads**, by Elmer Keith, The Gun Room Press, Highland Park, NJ, 1986. 151 pp., illus. \$24.95

**Speer Reloading Manual No. 13**, edited by members of the Speer research staff, Omark Industries, Lewiston, ID, 1999. 621 pp., illustrated. \$24.95

**Stopping Power: A Practical Analysis of the Latest Handgun Ammunition**, by Marshall & Sanow. Boulder, CO: Paladin Press, 2002. 1st edition. 600+ photos, 360 pp. Softcover. \$49.95

**Street Stoppers, The Latest Handgun Stopping Power Street Results**, by Marshall & Lanow. Boulder, CO, Paladin Press, 1996. 374 pages, illus. Softcover. \$42.95

**Understanding Ballistics, Revised 2nd Edition** by Robert A. Rinker, Mulberry House Publishing Co., Corydon, IN, 2000. 430 pp., illus Paper covers. New, Revised and Expanded. 2nd Edition. \$24.95

**Why Not Load Your Own?**, by Col. T. Whelen, Gun Room Press, Highland Park, NJ 1996, 4th ed., rev. 237 pp., illus. \$20.00

**Wildcat Cartridges Volumes 1 & 2 Combination**, by the editors of Handloader magazine, Wolfe Publishing Co., Prescott, AZ, 1997. 350 pp., illus. Paper covers. \$39.95

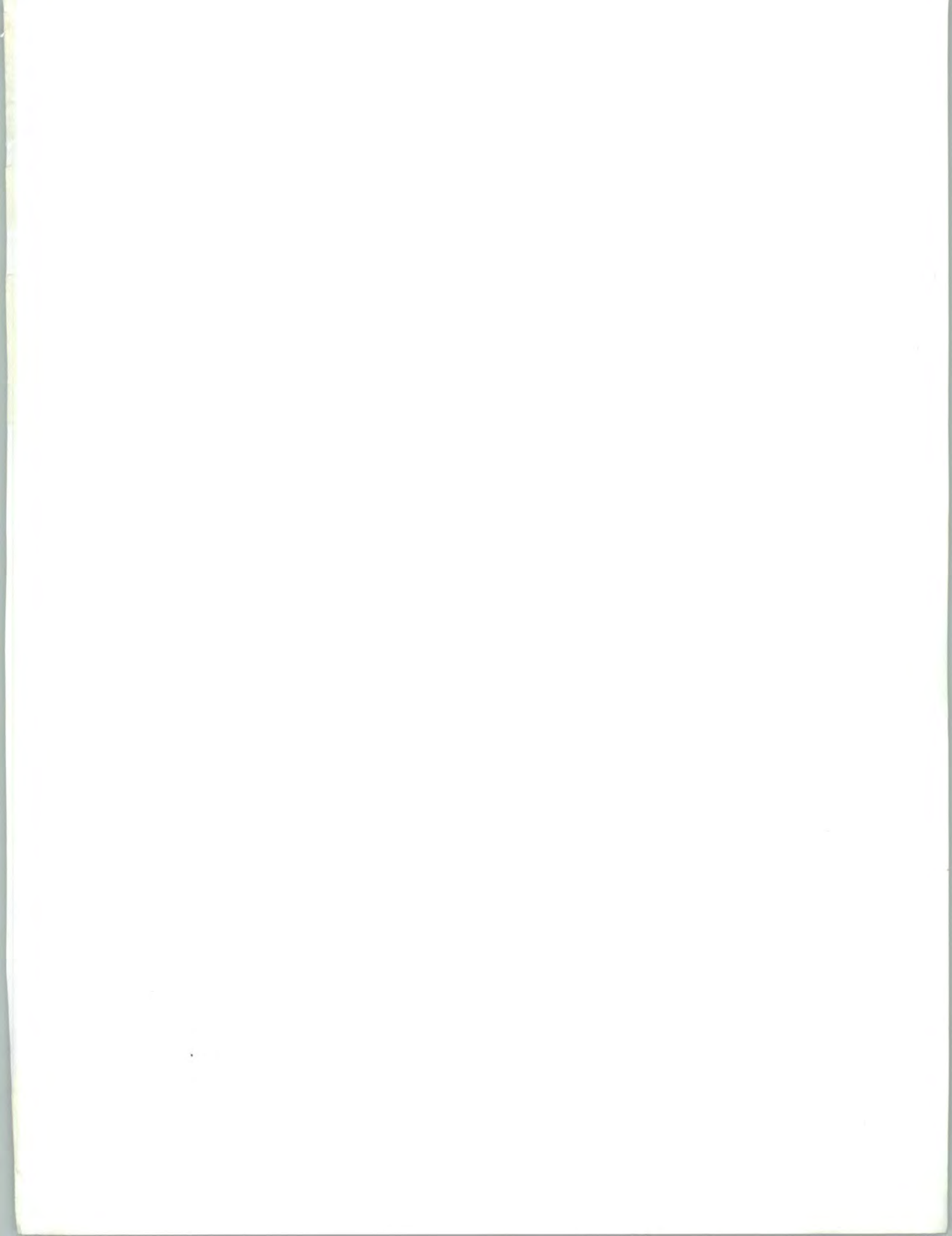

DEFINITIVE GUIDE TO CARTRIDGE AND SHOTSHELL RELOADING

# THE ABC'S OF RELOADING

7<sup>th</sup> Edition



**Gun Digest Books**  
An imprint of F+W Publications  
888-457-2873

ISBN: 0-87349-851-8 \$21.99 U.S.  
(\$32.99 CAN)

